

KLA 418
ANADOLU'DA ROMA MİMARİSİ

8. Hafta

TİYATRO - AMPHİTİYATRO

GREEK TIYATROSU

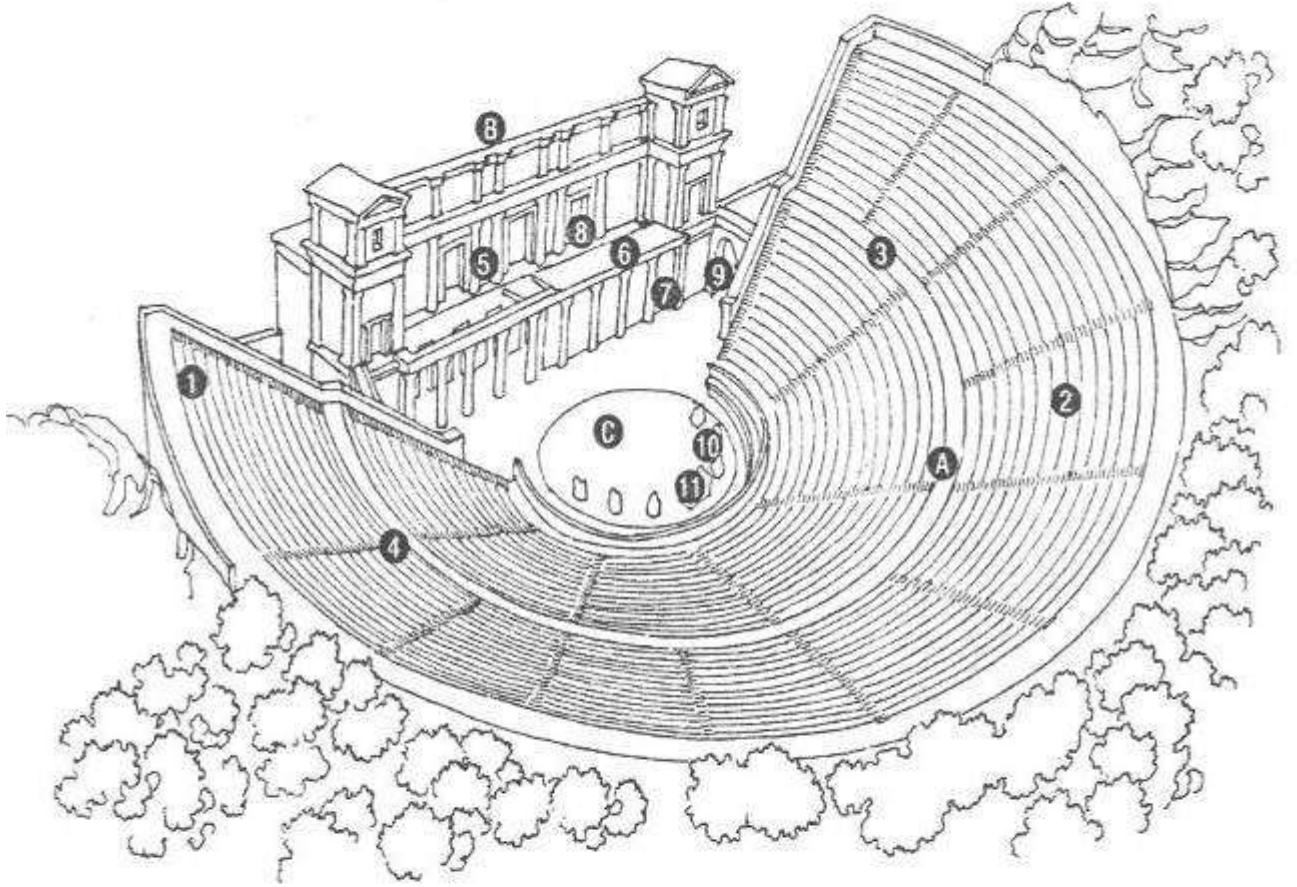

A. Koilon (*Cavea*)

1. *Analemnata*
2. *Kerkides*
3. *Diazomata*
4. *Klimakes*

B. Szene

5. *Skene*
6. *Proskenion*
7. *Pinakes*
8. *Thyromata*

C. Orchestra

9. *Parodoi*
10. *Prohedrie*
11. *Dionysos-Altar (Thymele)*

3 ana bölümden oluşan Hellen tiyatrosunda ilk başlarda oyunlar orkestra adı verilen yuvarlak alanda oynanmaktaydı. Hellenistik dönem itibarıyla sahne binası anlamına gelen skenenin ön kısmındaki proskenion adlı bölümde oynanmaya başlanılmıştır. Seyircilerin oyunları izledikleri oturma sıraları ise Theatron, Cavea veya Koilon olarak adlandırılmaktadır.

ROMA TIYATROSU

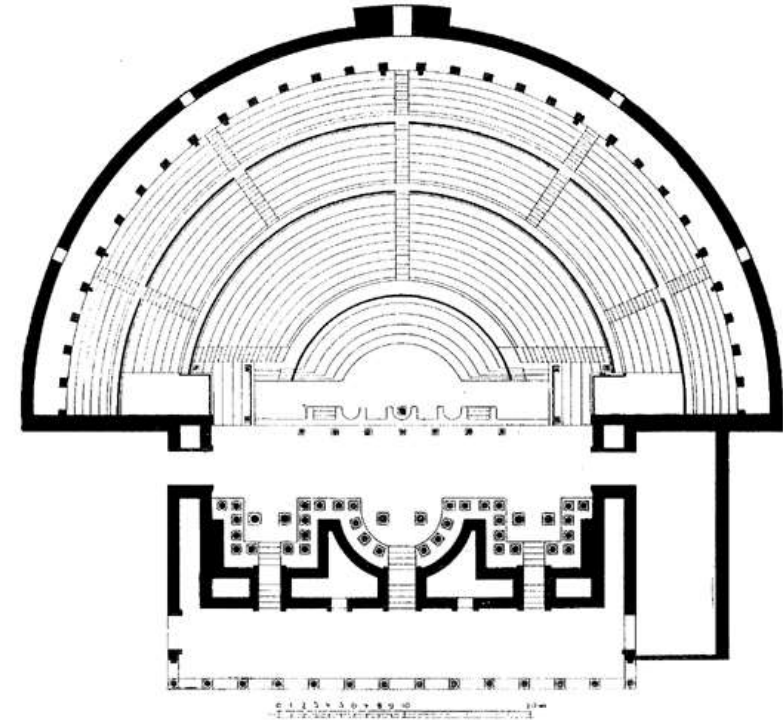
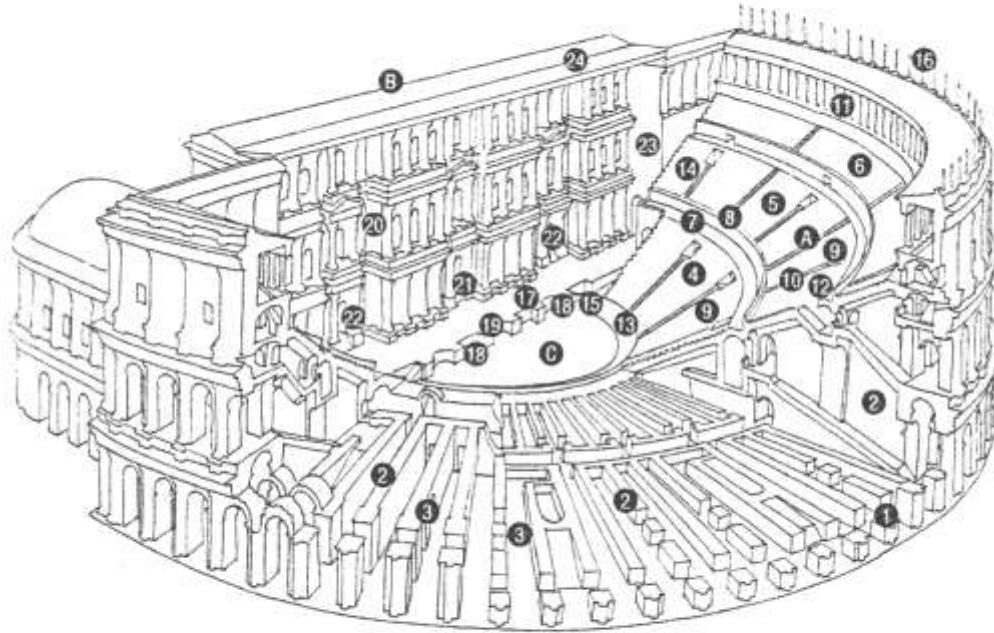

A. Cavea

1. Wandelgang (*ambulacrum*)
2. Substruktionen
3. Bogengänge
4. *Ima cavea - maenianum*
5. *Media cavea - maenianum*
6. *Summa cavea - maenianum*
7. Horizontale Umgänge (*praecinctiones*)
8. *Balteus*
9. *Cunei*
10. Treppen (*scalaria*)
11. *Porticus in summa cavea oder in summa gradatione*
12. *Vomitorien*
13. *Prohedrie*
14. *Tribunalia*
15. *Parodoi*
16. *Abstützungen des velum*

B. Szene

17. *Pulpitum*
18. *Frons pulpiti*
19. *Aulaeum*
20. *Scaenae frons*
21. *Porta regia*
22. *Portae hospitales*
23. *Aulae*
24. *Postscaenium*

C. Orchestra

ROMA TIYATROSU

Roma İmparatorluk Dönemi'nin gösterilere getirdiği en büyük yenilik, insanların birbiriyle ölümüne çarpıştırıldığı gladyatör dövüşleri, vahşi hayvanlarla insanların ya da hayvanların birbirleriyle dövüştürüldüğü oyunlar (venationes) ve su oyunları oldu.

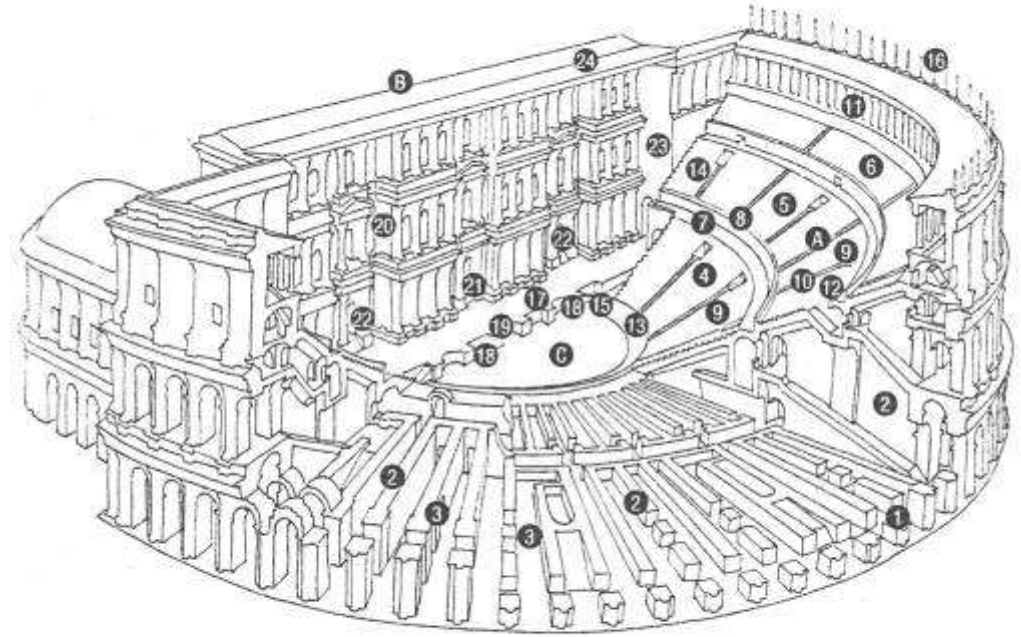

Bu işlev için orkestra ile cavea arasındaki bağlantı yüksek duvarlarla yok edilmiş ve gerekli durumlarda su ile doldurulabilecek hale getirilmiştir.

Tiyatrolar ise proskenionda oynanmaya devam etmiştir.

A. Cavea

1. Wandelgang (ambulacrum)
2. Substruktionen
3. Bogengänge
4. Ima cavea - maenianum
5. Media cavea - maenianum
6. Summa cavea - maenianum
7. Horizontale Umgänge (praecinctions)
8. Balteus
9. Cunei
10. Treppen (scalaria)
11. Porticus in summa cavea oder in summa gradatione
12. Vomitorien
13. Prohedrie
14. Tribunalia
15. Parodoi
16. Abstützungen des velum

B. Szene

17. Pulpitum
18. Frons pulpiti
19. Aulaeum
20. Scaenae frons
21. Porta regia
22. Portae hospitales
23. Aulae
24. Postscaenium

C. Orchestra

GREEK TIYATROSU

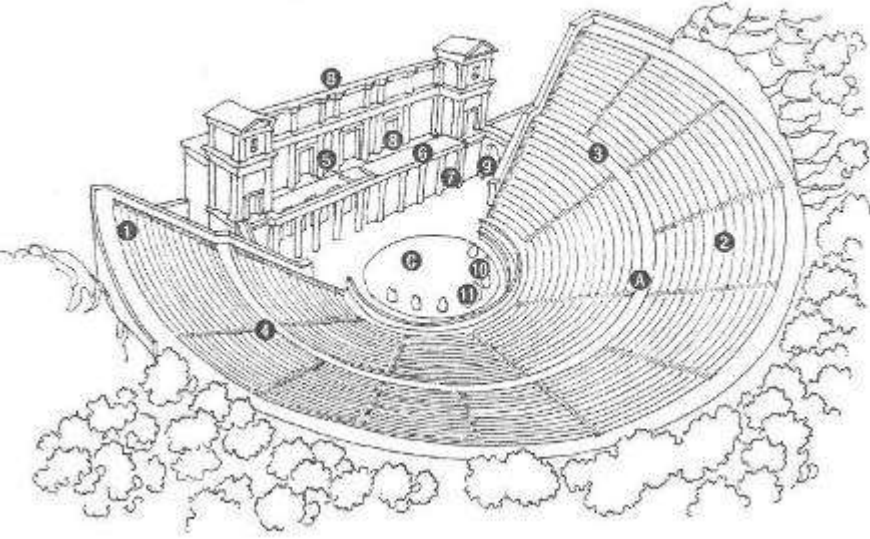

ROMA TIYATROSU

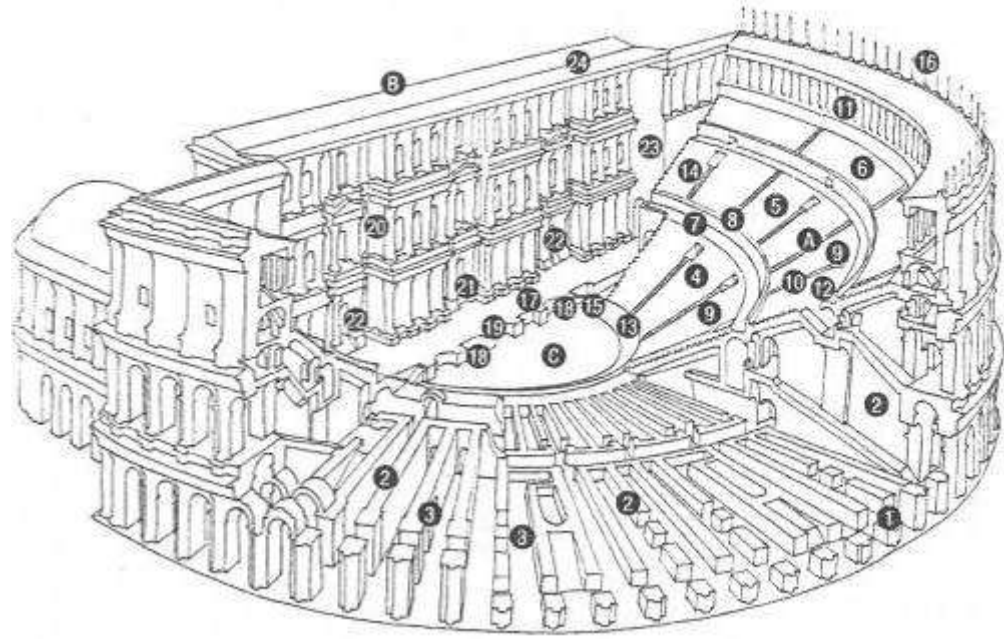

YUNAN VE ROMA TİYATROLARI ARASINDAKİ FARKLAR NELERDİR?



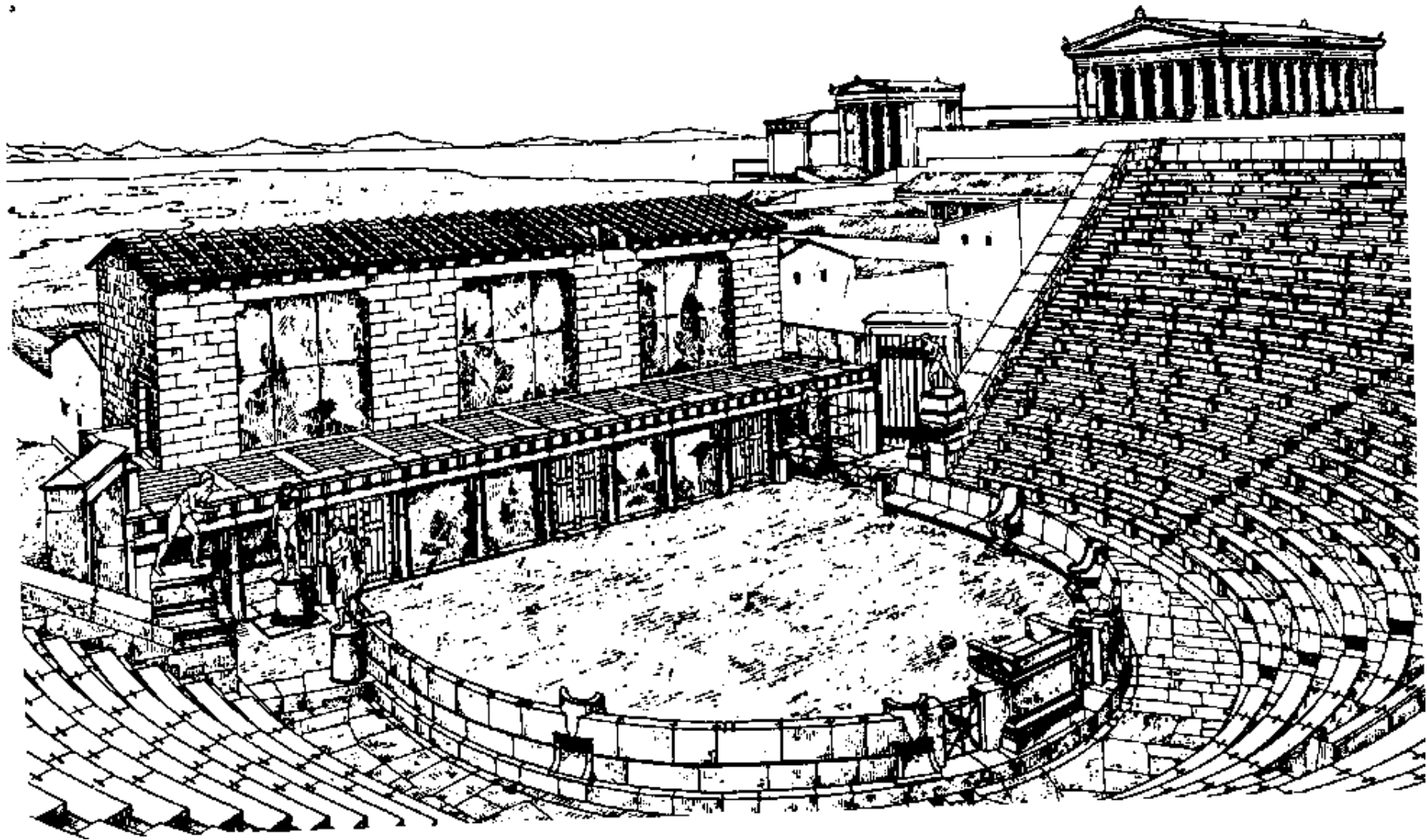

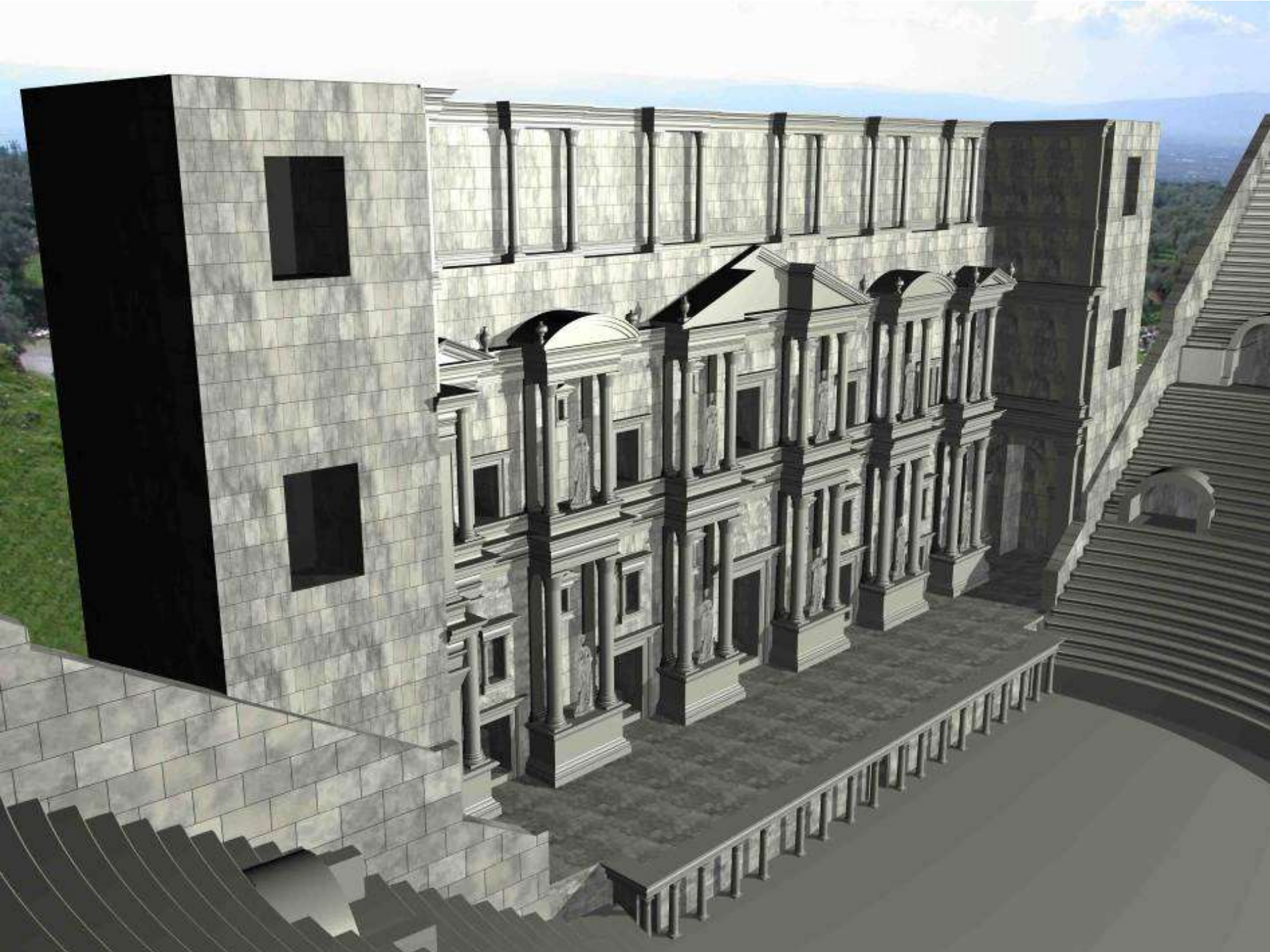

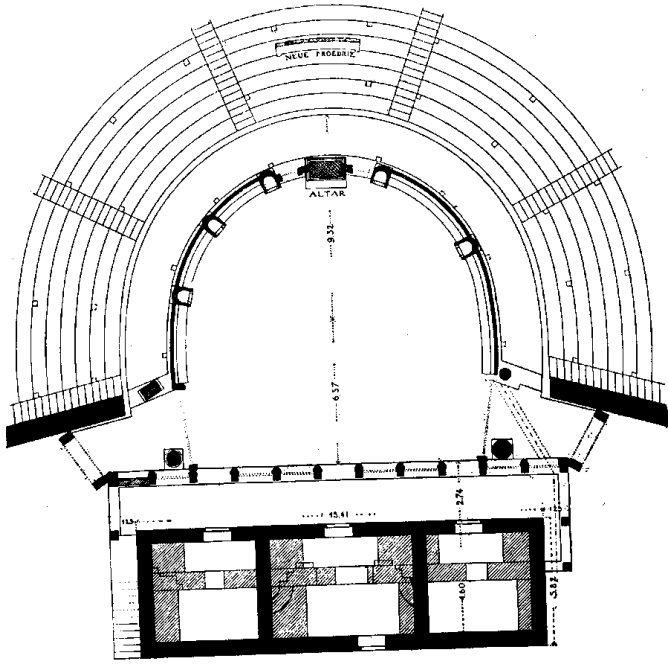

Şek. 343 - Priene. Tiyatro. Yapı planı (bkz. Şek. 344).

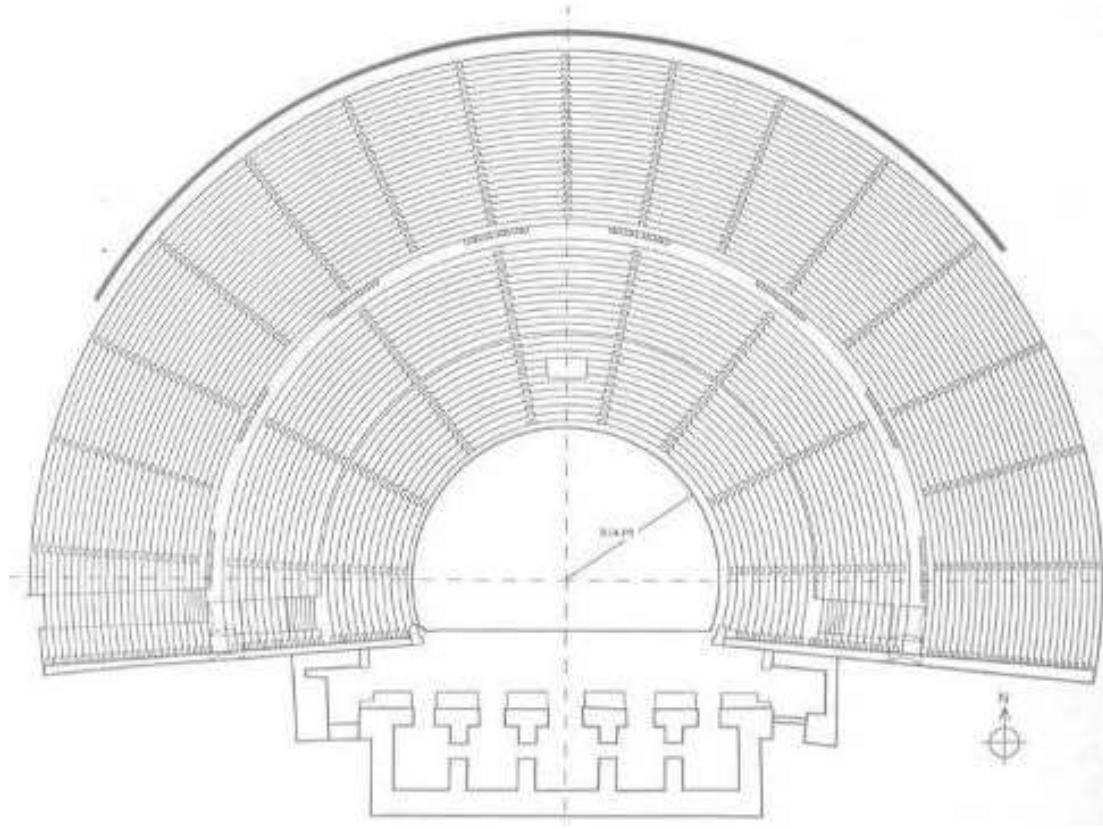

Yunan tiyatrolarının sahnesi dar iken, Roma tiyatrolarının sahnesi daha derinleştirilerek büyütülmüştür.

Yunan tiyatrosu açık paradi - girişlere sahipken,
Roma tiyatrosu üzeri kapalı - tonozlu girişlere
sahiptir.



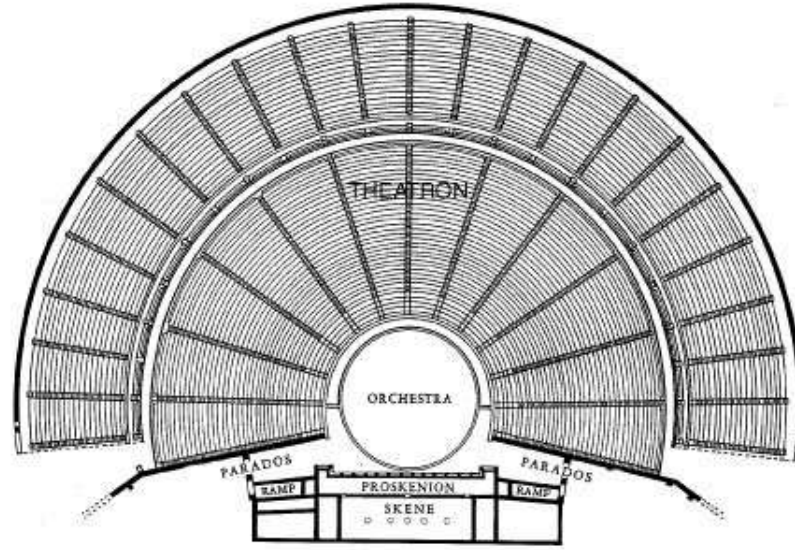

Yunan tiyatrosunun planı yarım daireden daha büyük at nalı şeklinde iken Roma tiyatrosu tam yarım dairedir.

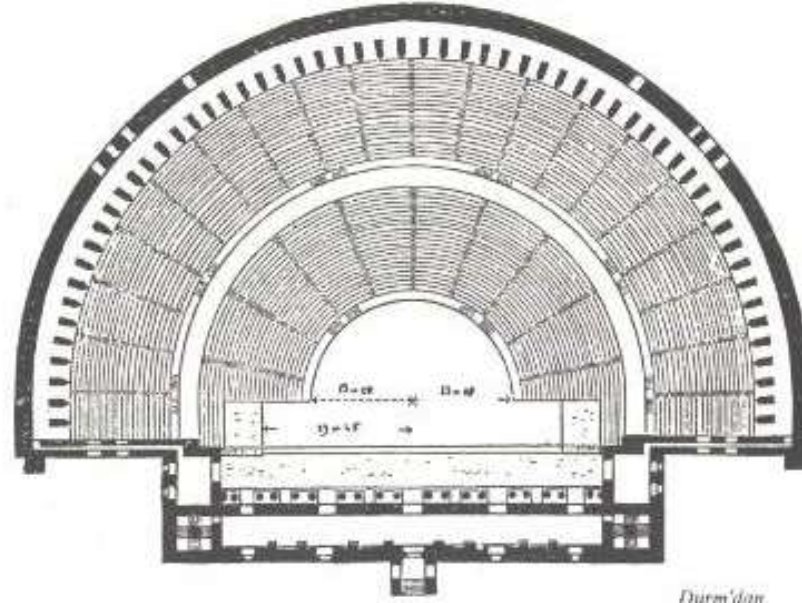

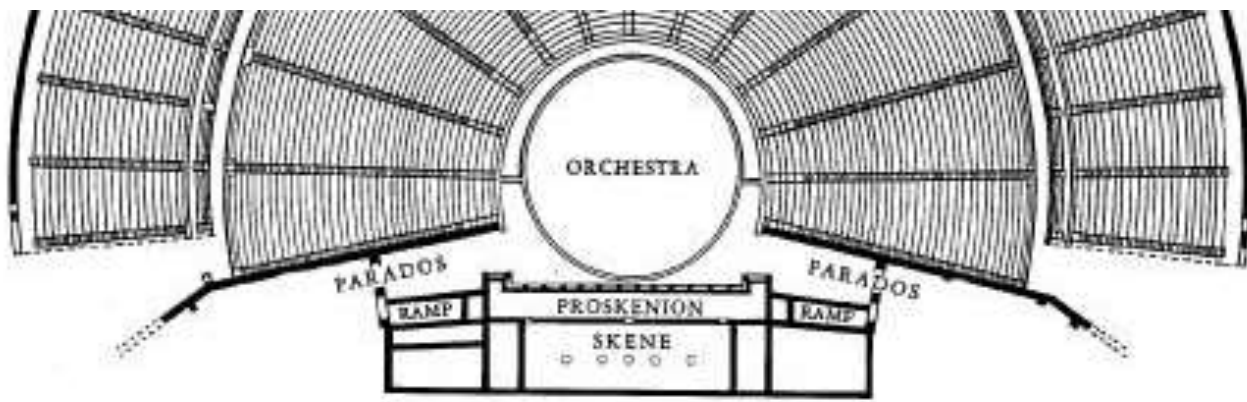

Yunan tiyatrosu planından ötürü eğimli analemma duvarlarına sahipken, Roma tiyatrosu düz duvarlara sahiptir.

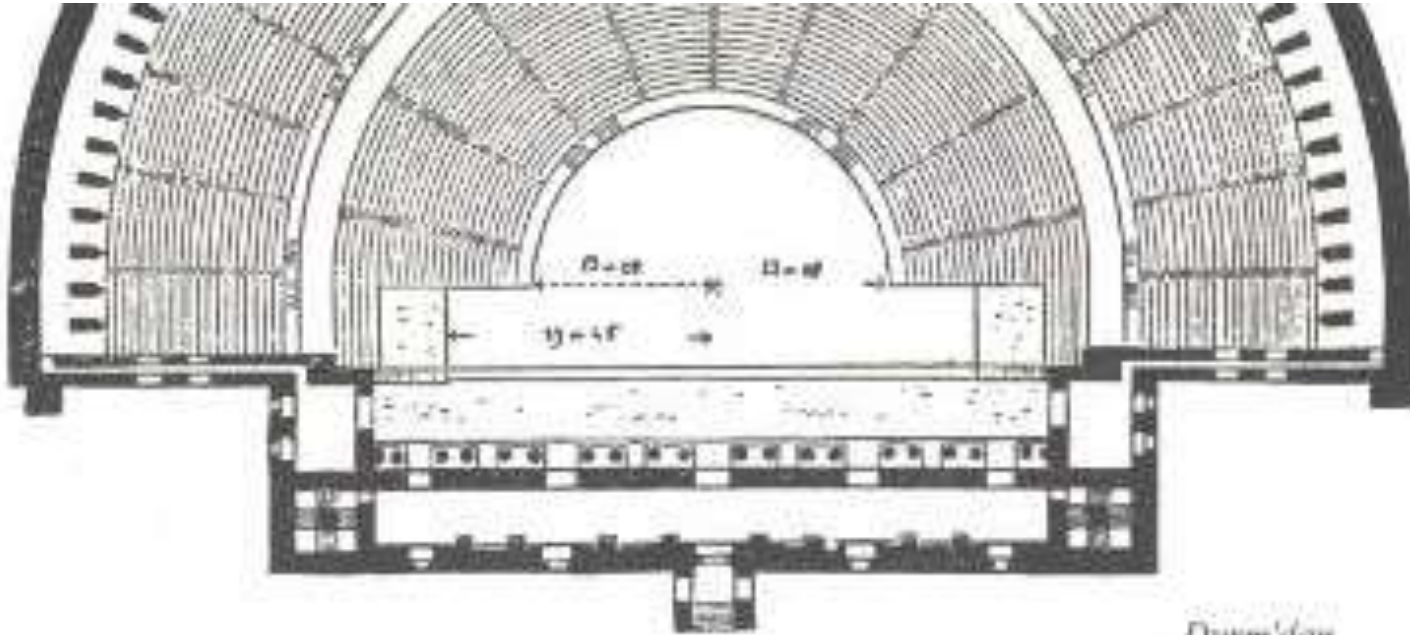

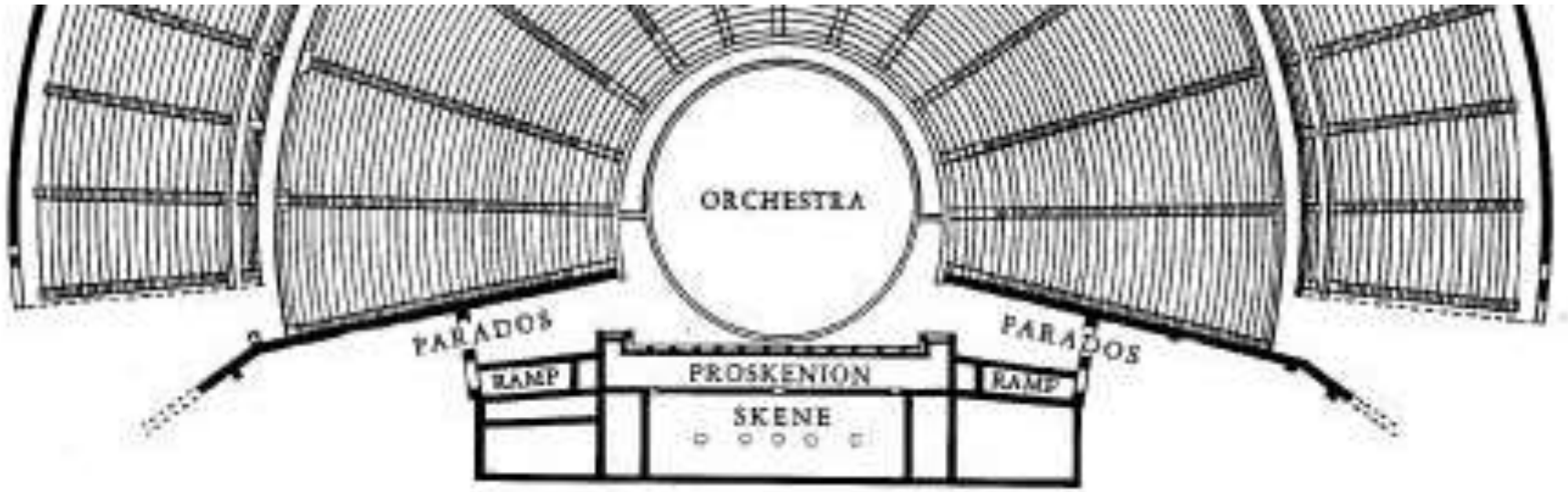

Yunan tiyatrosunun orkestrası tam daire oluştururken, Roma tiyatrosunun orkestrası yarım daire oluşturur.

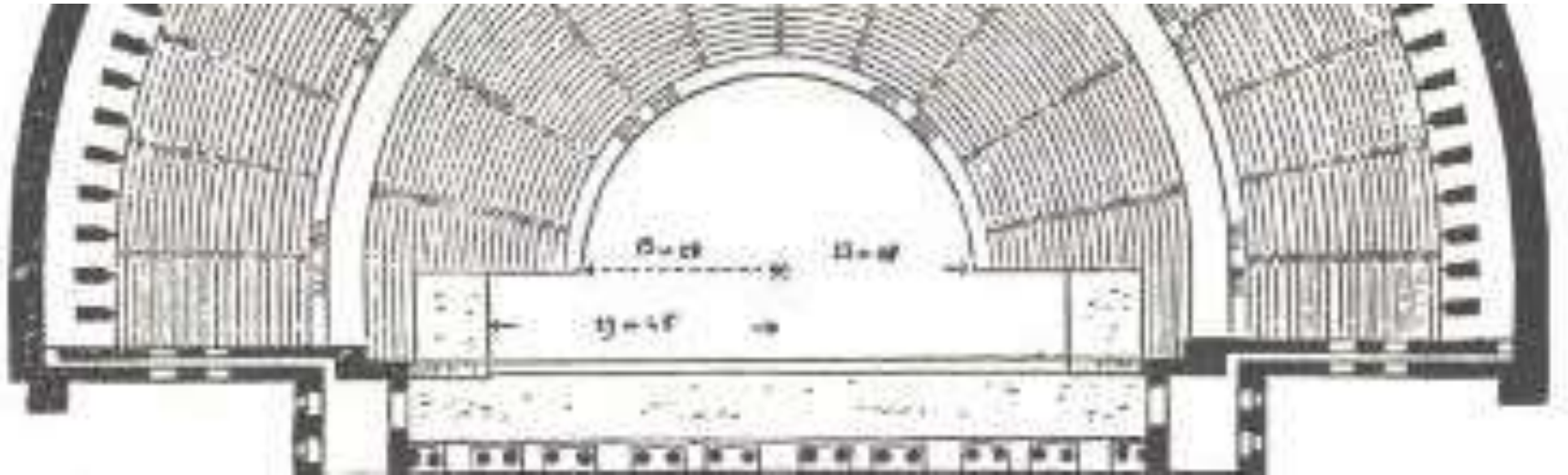

Yunan tiyatrosu proskenionu daha yüksek,
Roma tiyatrosu proskenionundan daha alçaktır.

Yunan tiyatrosunun proskenionu yarım sütun ve bu sütunlar arasında
pinakslar mevcut iken,
Roma tiyatrosunda kapalı duvarlar ile sütunlu proskenion cephesi vardır





Yunan tiyatrosunun cavea'sı bir yamaca yaslanırken, Roma Dönemi tiyatrolarının cavea'ları tonozlu altyapılar üzerine inşa edilmektedir.



Roma tiyatrosunda üst cavea'nın bitiminde sütunlu bir galeri bulunur.





Roma tiyatrolarında tonozlu Diazoma'lar görülür



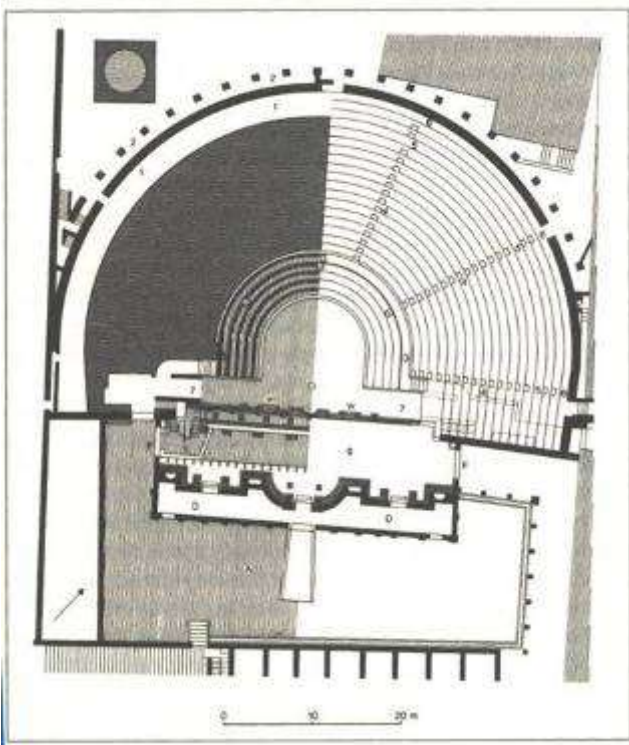

Roma-İmparatorluk tipi scaenae frons,
Pompeii Tiyatrosu

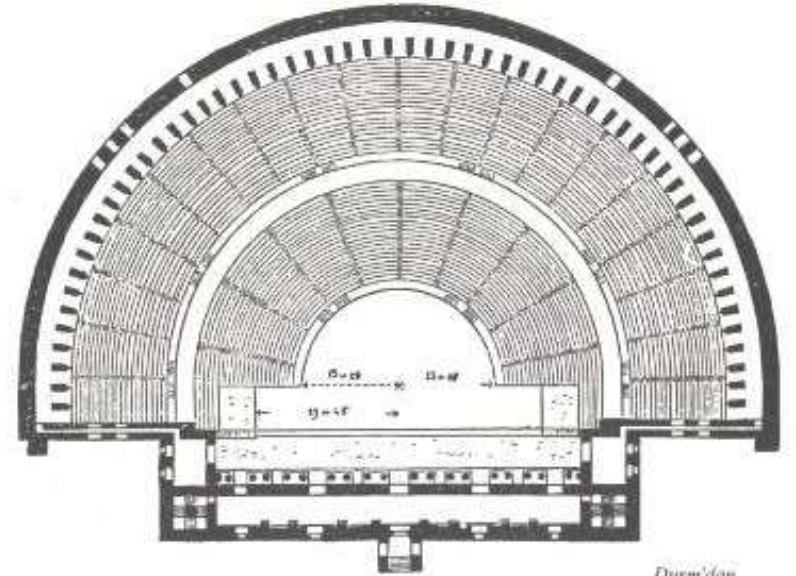

ASPENDOS TIYATROSU

Anadolu-Roma tipi scaenae frons





BATI ANADOLU'NUN ESKİ ÇAĞ TİYATROLARI

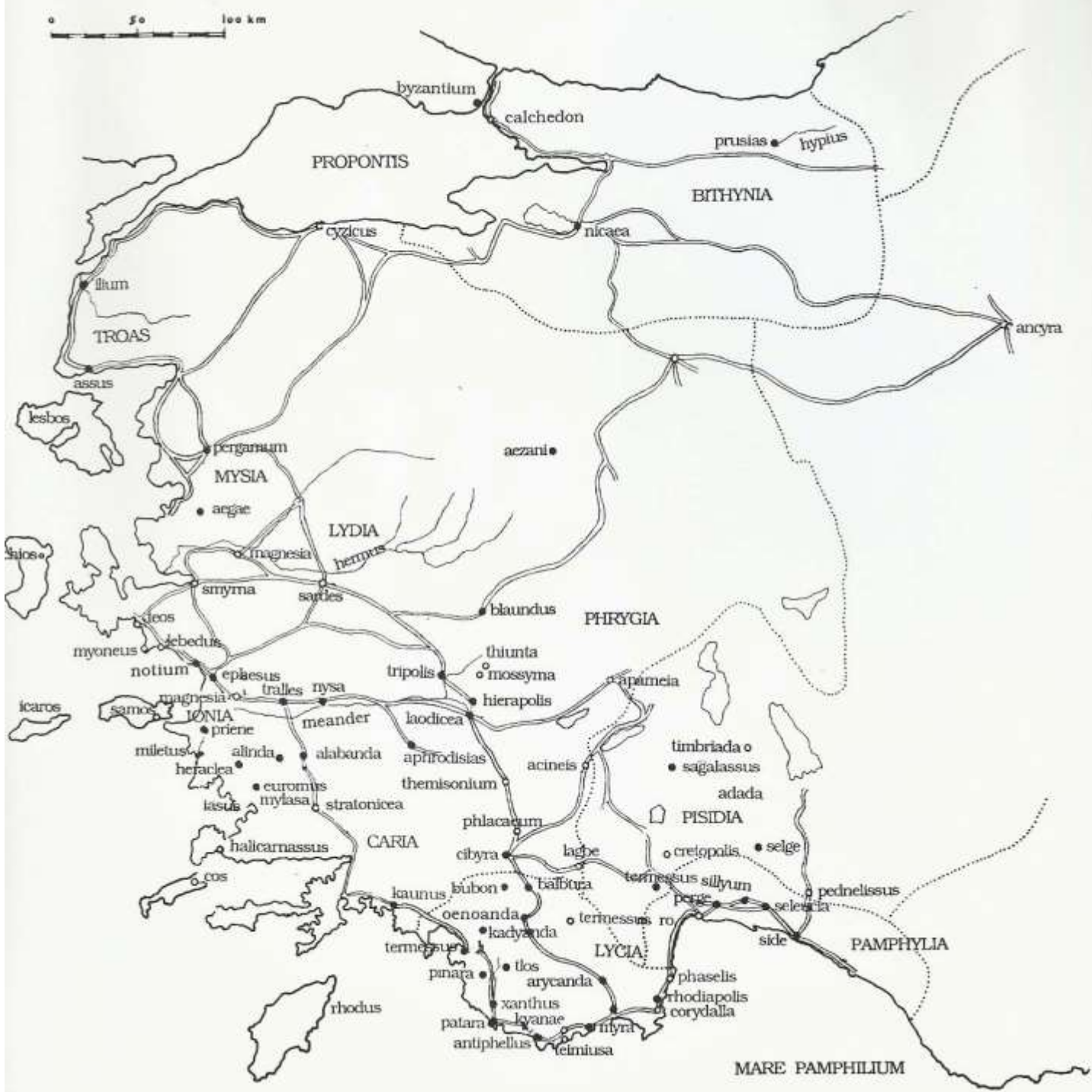

Anadolu'da hemen hemen 140'a yakın antik tiyatro bilinmektedir. Ancak bunların sadece belirli bir sayısı iyi korunmuş durumdadır. Mevcut tiyatro yapılarının büyük bir bölümü Hellen çağında inşa edilmiş oldukları için Hellen yapı tipine sahiptir, ancak sonraki dönemlerde pek çok defa değişiklik geçirmişlerdir.

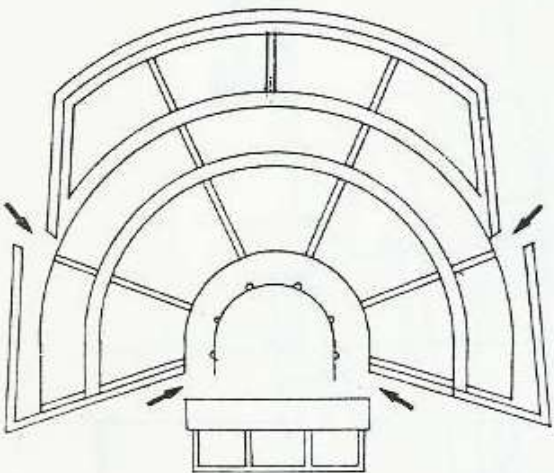

PRIENE İ.Ö. 250-225

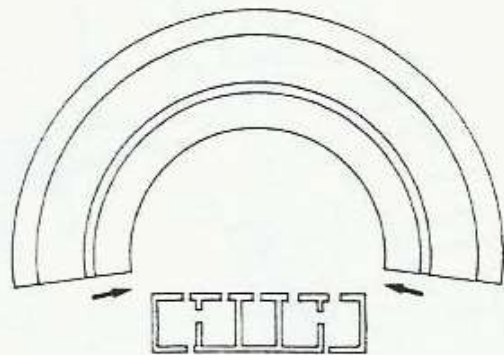

HERACLEA (LATMUS) İ.Ö. 250-200

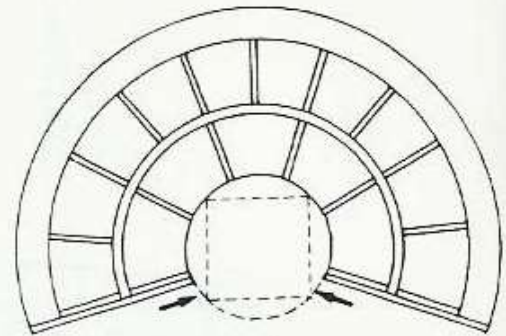

KYANAE İ.Ö. 210-180

PERGAMON (Bergama): MÖ 3.yy.a tarihlenen tiyatro yaklaşık 10.000 seyirci kapasitelidir. Sahne binası bulunmayan yapıda oyunların ahşap sahnelerde oynanmış olduğu düşünülmektedir.

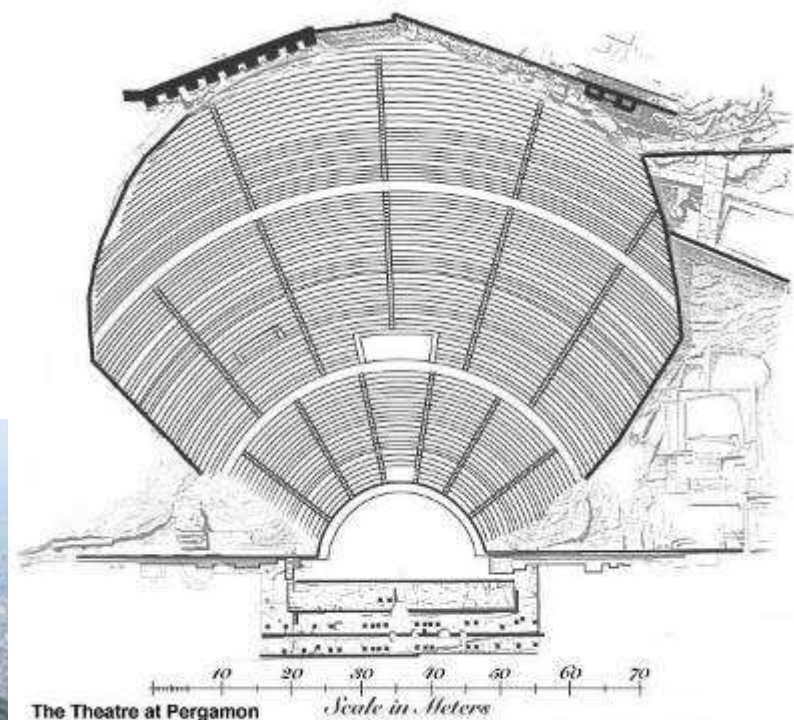
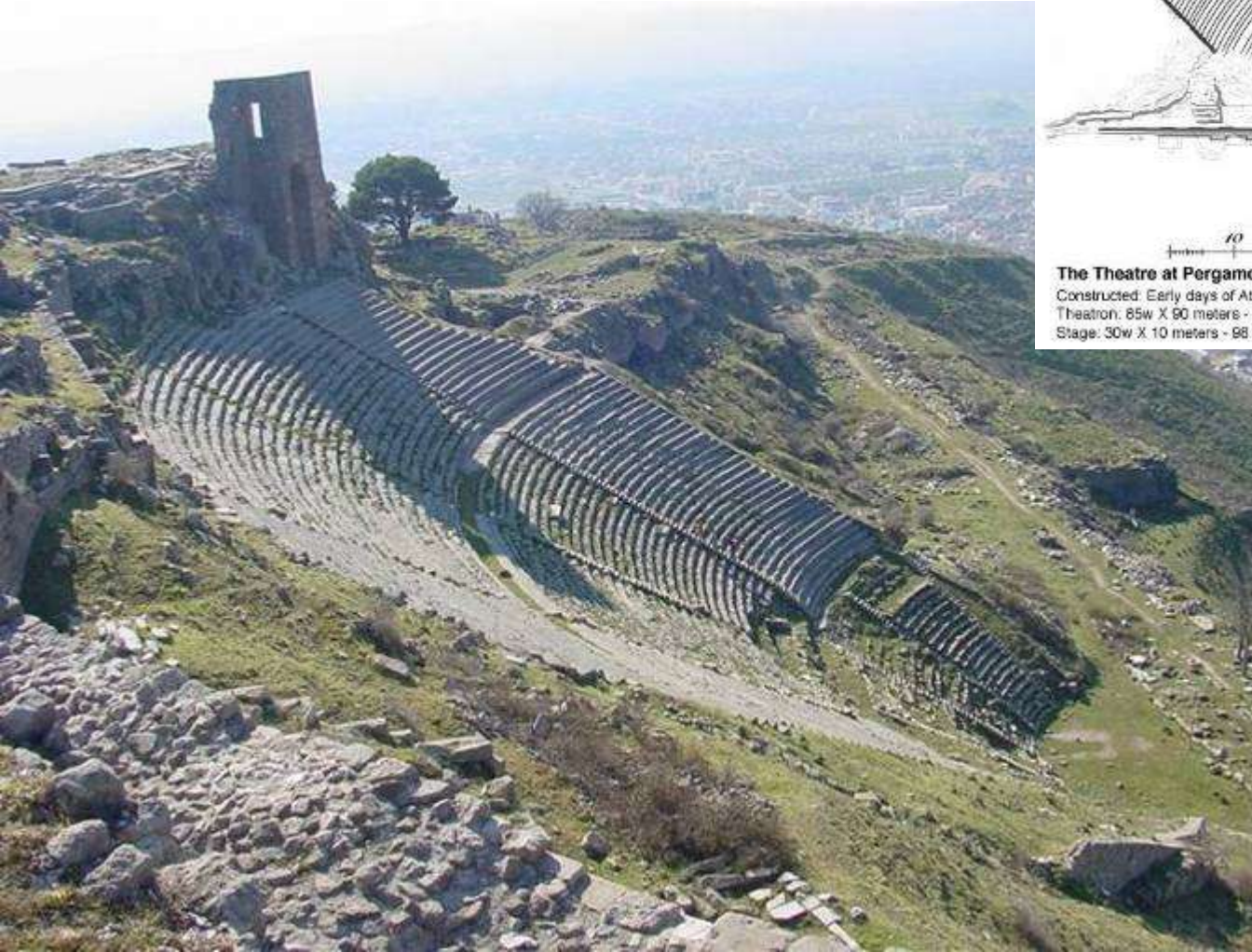

The Theatre at Pergamon

Scale in Meters

Constructed: Early days of Attalid Kingdom, mid-3rd century BC; enlarged to final form 187-159 BC
Theatron: 65w X 90 meters - 219w X 295 feet - Orchestra: 21w X 11 meters - 69 X 36 feet
Stage: 30w X 10 meters - 98 X 33 feet - Cavea 122 ft. high

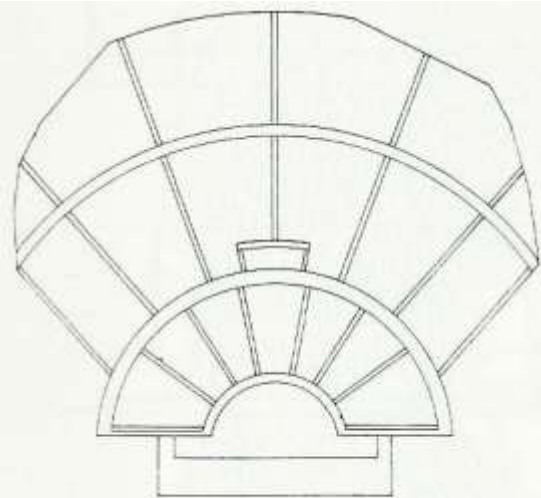

PERGAMUM İ.Ö. 225-138

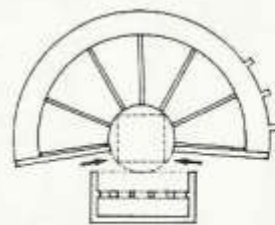

RHODIAPOLIS Yaklaşık İ.Ö. 150

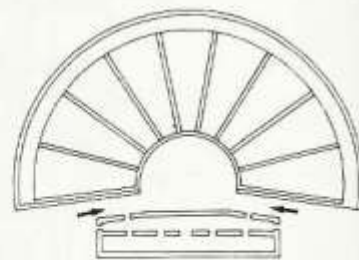

PINARA Yaklaşık İ.Ö. 50

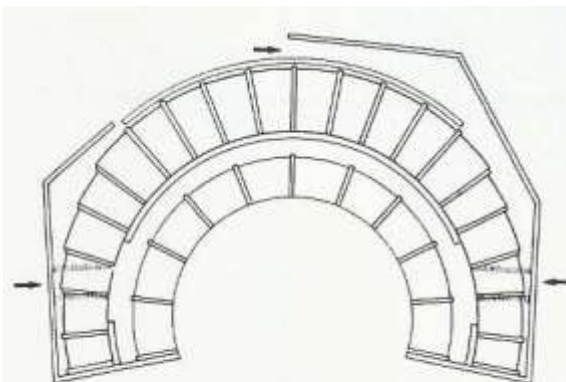

LETOON İ.Ö. 110-90

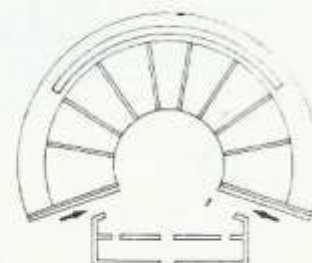

KADYANDA Yaklaşık İ.Ö. 50

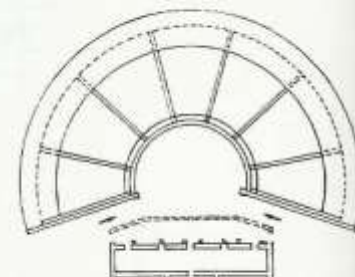

ARYCANDA Yaklaşık İ.Ö. 50

ASSOS (Behramkale-Çanakkale)
: MÖ 250 yıllarına tarihlenen
tiyatro at nalı formlu bir
orkestraya sahiptir.

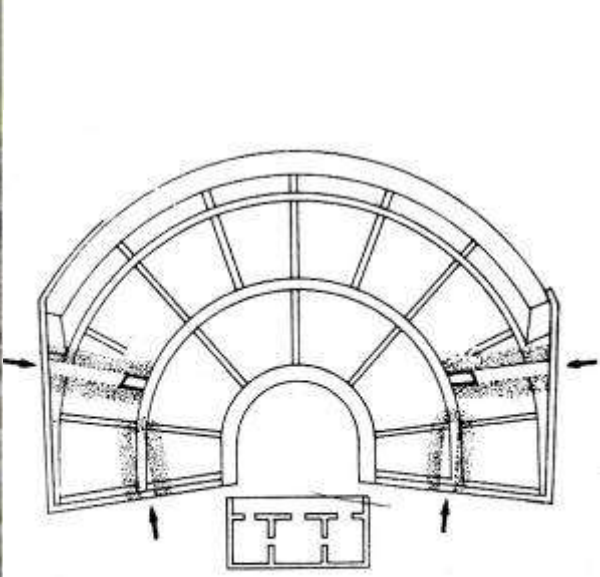

ASSUS Yaklaşık İ.Ö. 200

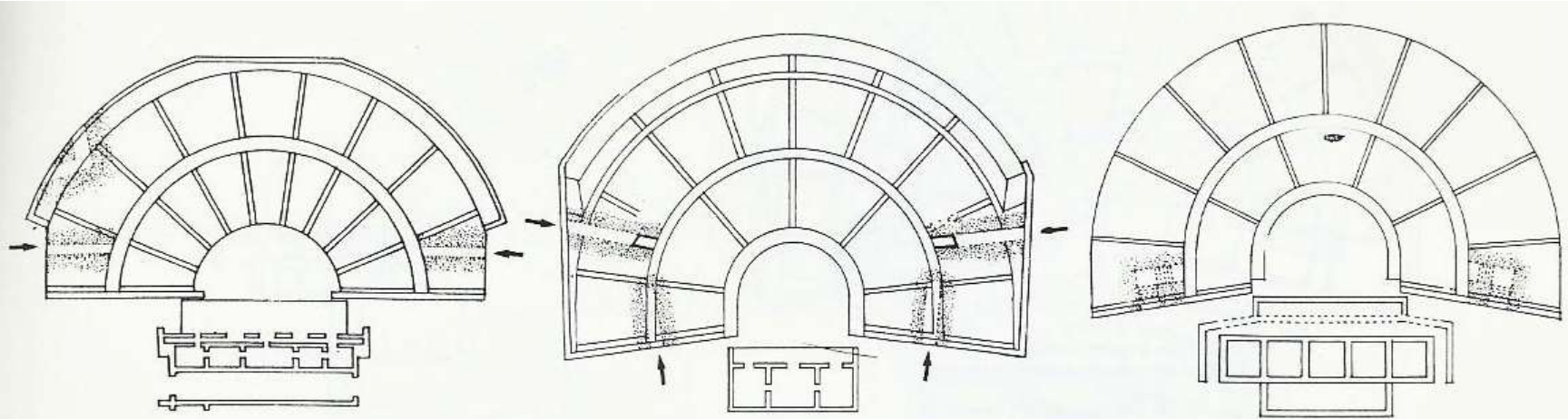

ALINDA İ.Ö. 202-175

ASSUS Yaklaşık İ.Ö. 200

MAGNESIA Yaklaşık İ.Ö. 160

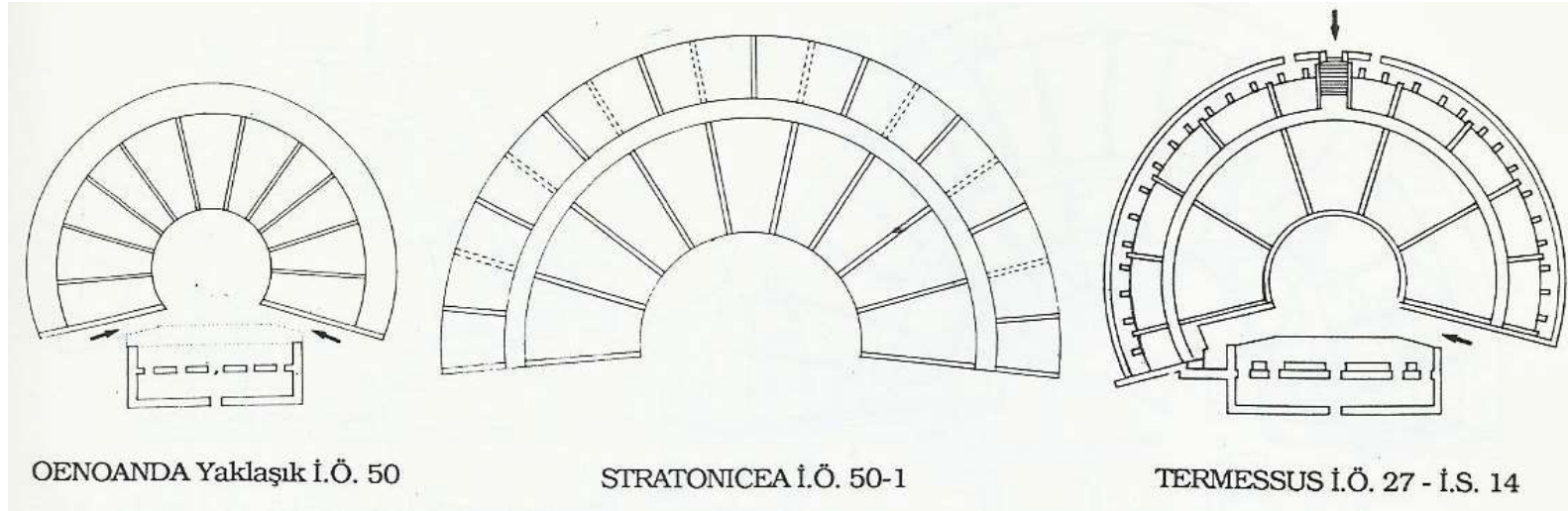

OENOANDA Yaklaşık İ.Ö. 50

STRATONICEA İ.Ö. 50-1

TERMESSUS İ.Ö. 27 - İ.S. 14

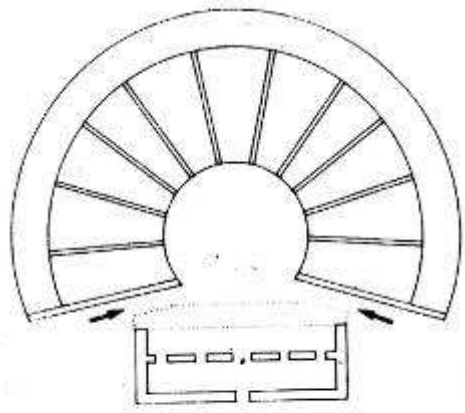

OENOANDA Yaklaşık İ.Ö. 50

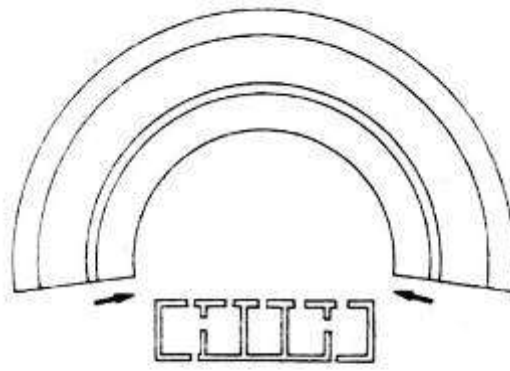

HERACLEA (LATMUS) İ.Ö. 250-200

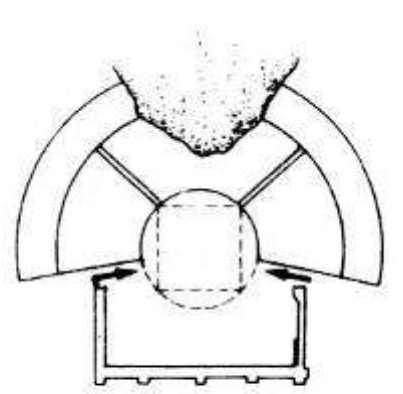

BALBURA Yaklaşık İ.ö. 150

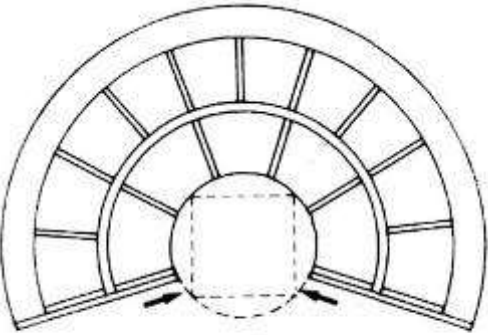

KYANAE İ.Ö. 210-180

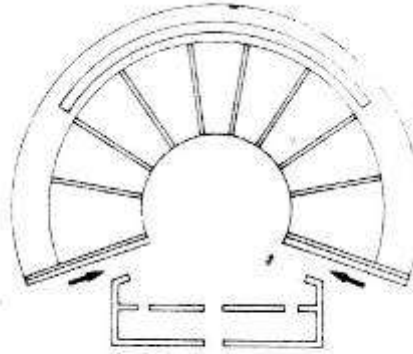

KADYANDA Yaklaşık İ.Ö. 50

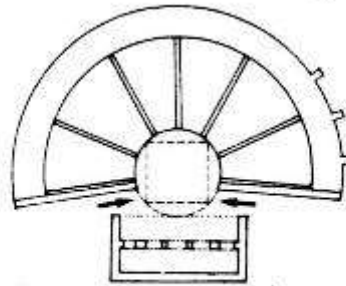

RHODIAPOLIS Yaklaşık İ.Ö.150

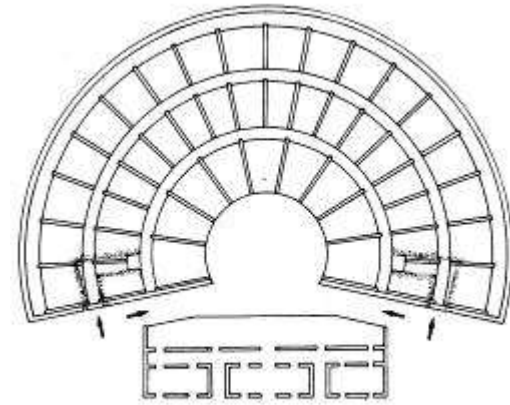

PRUSIAS AD HIPYUM İ.Ö. 10 - İ.S. 20

APHRODISIAS (Geyre-Karacasu-Aydın) :
Hellen kökenli olan tiyatro yapısı Roma
devrinde eklentilerle genişletilmiştir.

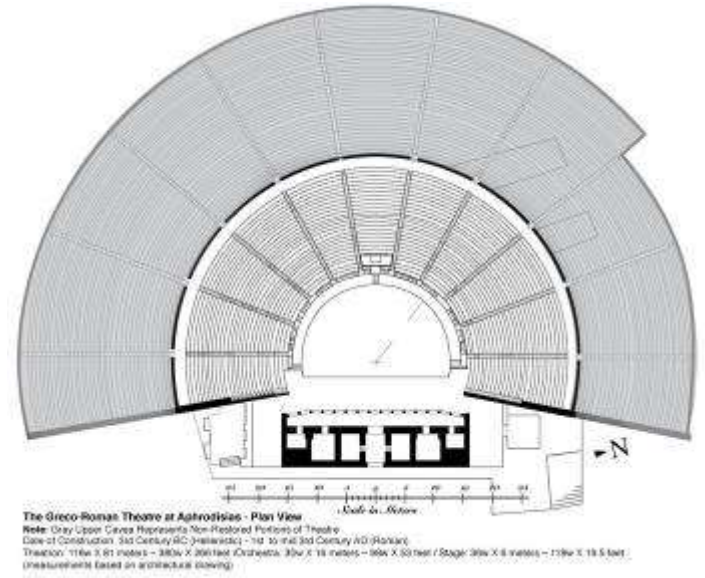
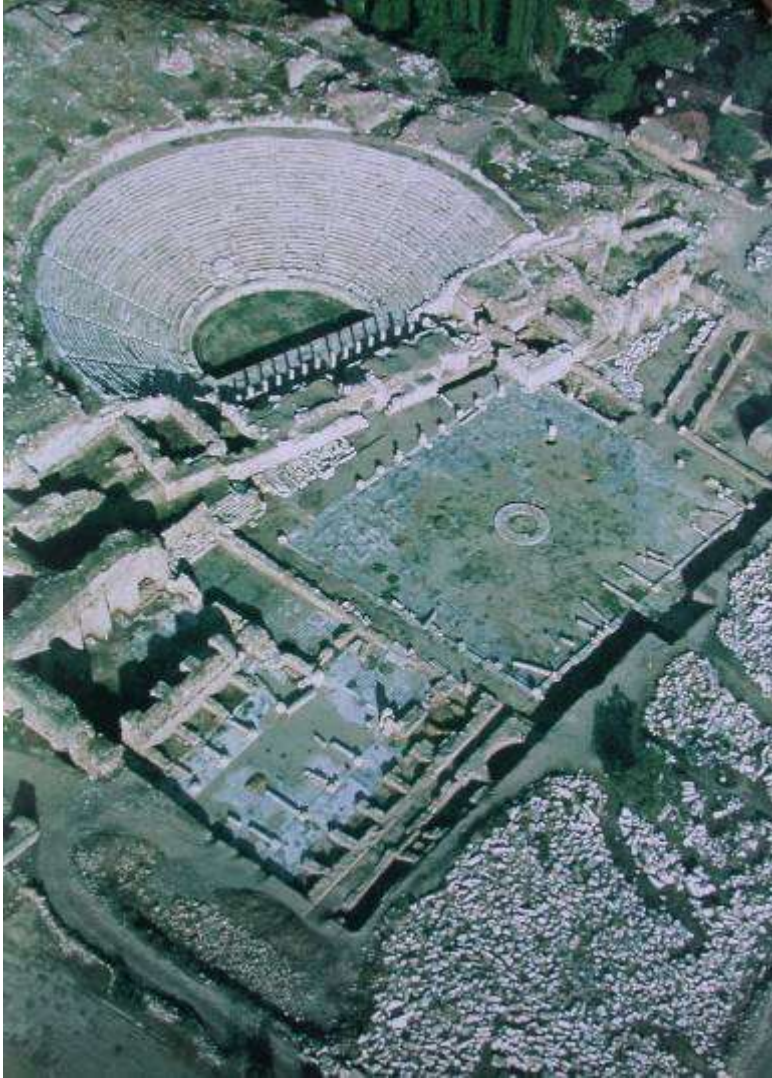



ALABANDA
(Çine-Aydın) :
Hellen kökenli
tiyatroda kazı
çalışmaları
devam
etmektedir.

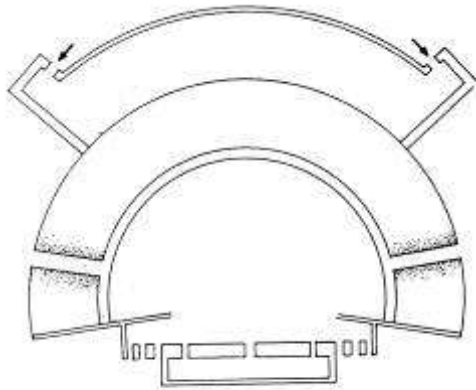

ALABANDA I.Ö. 27 - İ.S. 14



STRATONİKEİA (Eskihisar)

Hellenistik dönem kökenli olan tiyatronun sahne binası Augustus döneminde eklenilmiştir. 10.000 seyirci kapasiteli yapı kuzeye bakmaktadır.

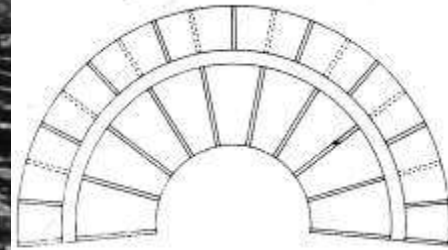

STRATONICEIA I.Ö. 50-1

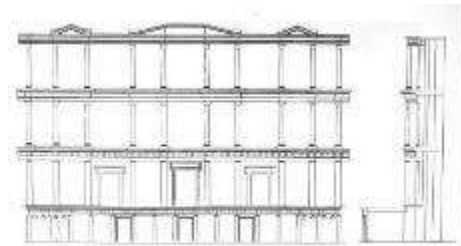

Miletos Tiyatrosu



Miletos, MÖ 300 civarında inşa edilen tiyatro Roma devrinde yenilenerek 15.000 seyirci kapasiteli hale getirilmiştir.

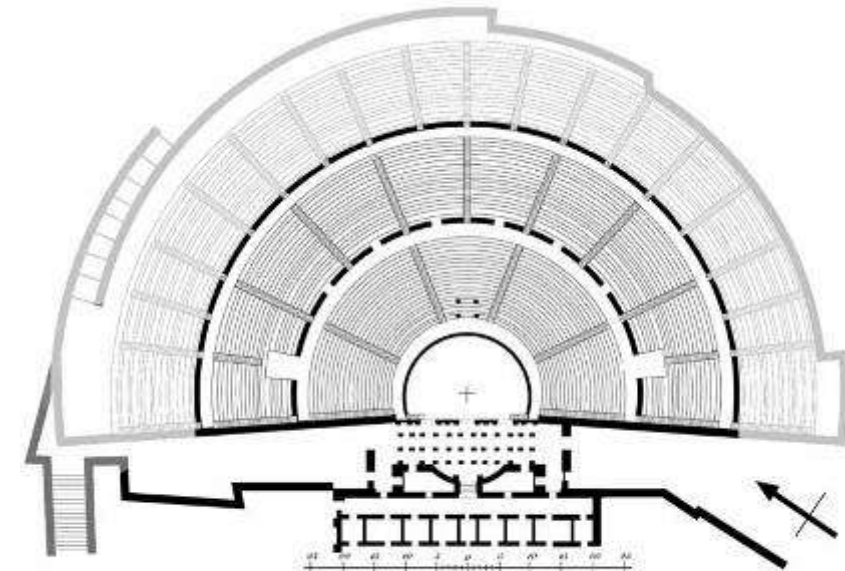

The Greco-Roman Theatre at Miletus - Plan View
Note: Reconstruction Drawing of Roman Theatre - Shaded Upper Cavea Represents Missing Portions of Theatre
Date of Construction: 3rd Century BC (Hellenistic) - 1st to mid 3rd Century AD (Roman) - Seating Capacity: (Hellenistic) - 5,300 (Roman) - 15,000
Theatron: 140m X 85 meters - 460m X 279 feet / Orchestra: 20m X 14 meters - 66m X 46 feet / Stage: 40m X 12 meters - 131m X 39 feet
(Approximate measurements based on reconstruction drawing)





Ephesos Tiyatrosu



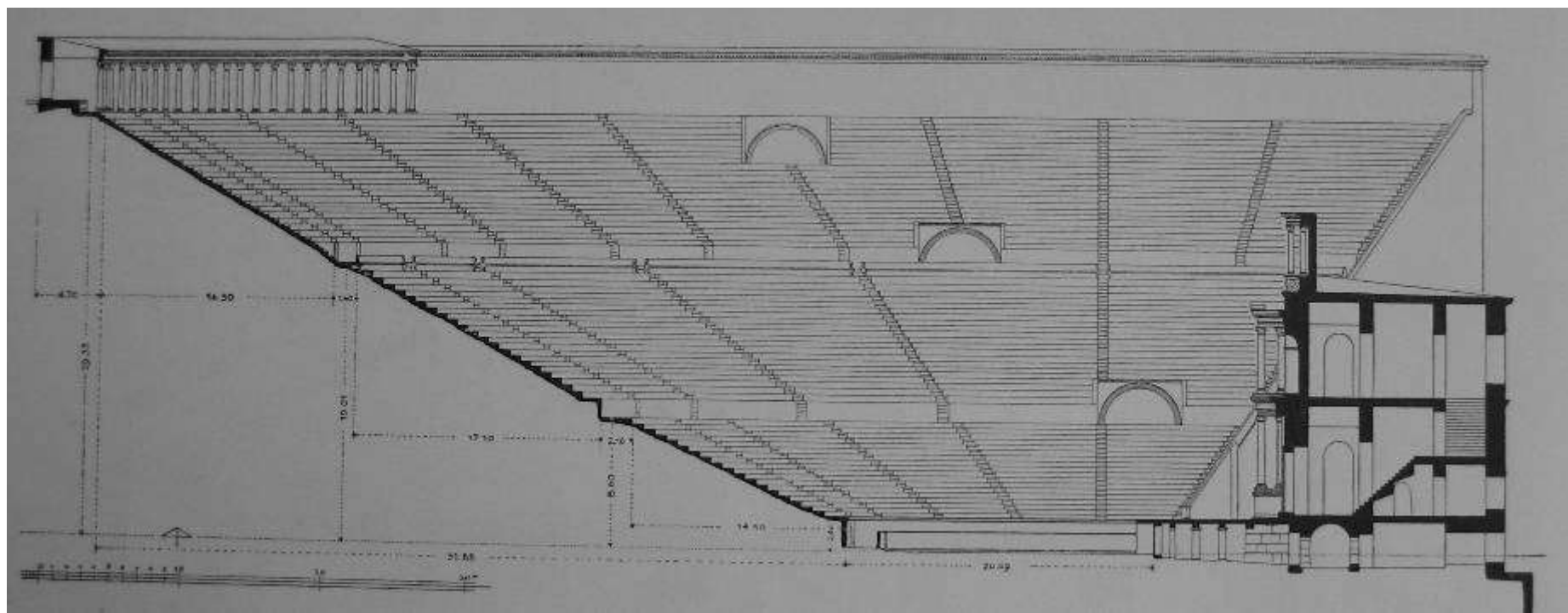

NYSA Tiyatrosu



Musa Kadıoğlu, *Die Scaenae Frons des Theaters von Nysa am Mäander*,
Forschungen in Nysa am Mäander Band 1, 2006



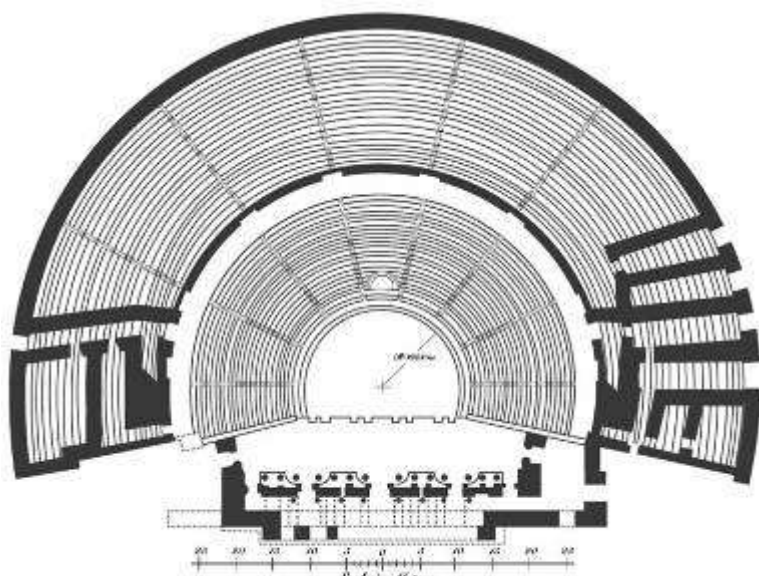

The Greco-Roman Theatre at Hierapolis - Plan View



HIERAPOLİS (Pamukkale)

Hellen tipindeki tiyatro MS.2.yy.a tarihlendirilmekle birlikte daha önceki evrelerinin bulunduğu kesindir. 15.000 seyirci kapasitelidir.

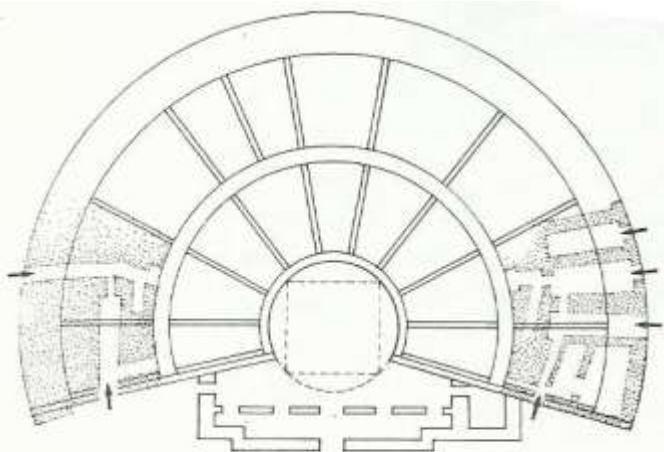

HIERAPOLIS ĩ.S. 117 - 137 ; ĩ.S. 204 - 211

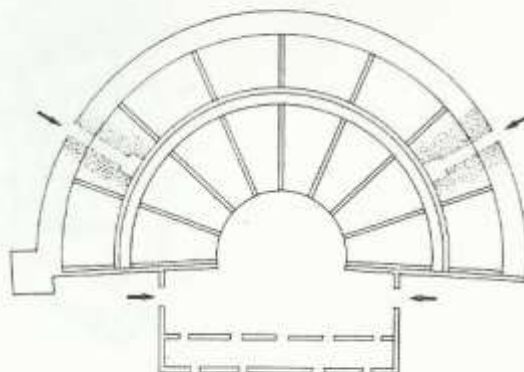

PATARA ĩ.Ö. 14 - 37 ; ĩ.S. 130 - 147

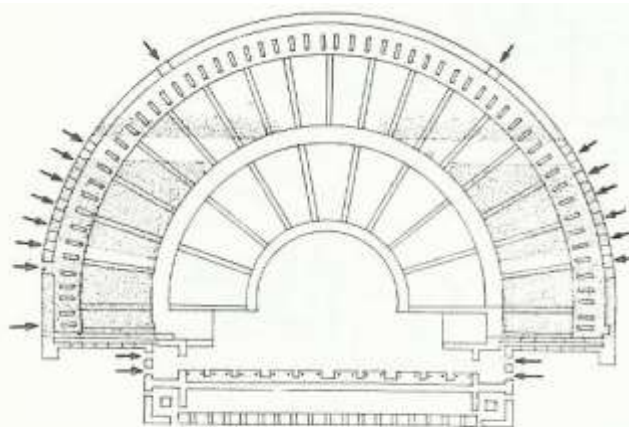

ASPENDUS ĩ.S. 139 - 168

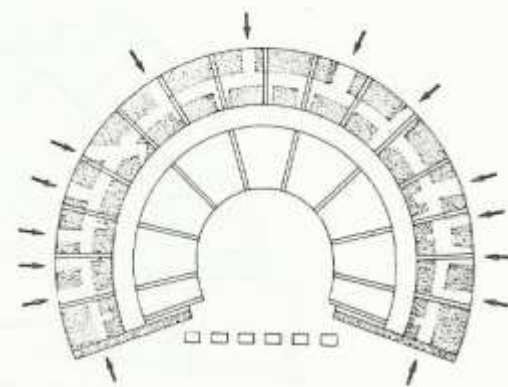

LIMYRA ĩ.S. 141 - 150 ; ĩ.S. 250

ASPENDOS (Belkıs-Antalya): Sahne binası ile theatronun uyumlu bileşimi burada görülmektedir. Tiyatro dış dünyadan ayrılmış, kendi içinde mimari çerçeveli kapalı bir mekandır. Küçük bir bölümü yamaca dayanmış olan tiyatronun üst kesimi tonozlar üzerinde inşa edilmiştir ve theatron at nalı biçimlidir. Ele geçen bir yazıttan öğrenildiğine göre M. Aurelius (MS 161-180) döneminde mimar Theodoros'un oğlu Zenon tarafından tasarlanmıştır. Aspendos tiyatrosu Anadolu'daki tiyatrolar arasında Roma tiyatro planını en iyi yansıtan örnektir. 10.000 kapasiteli olarak hesaplanmakla birlikte yapılan festivaller 20.000 kişi alabildiğini göstermektedir.

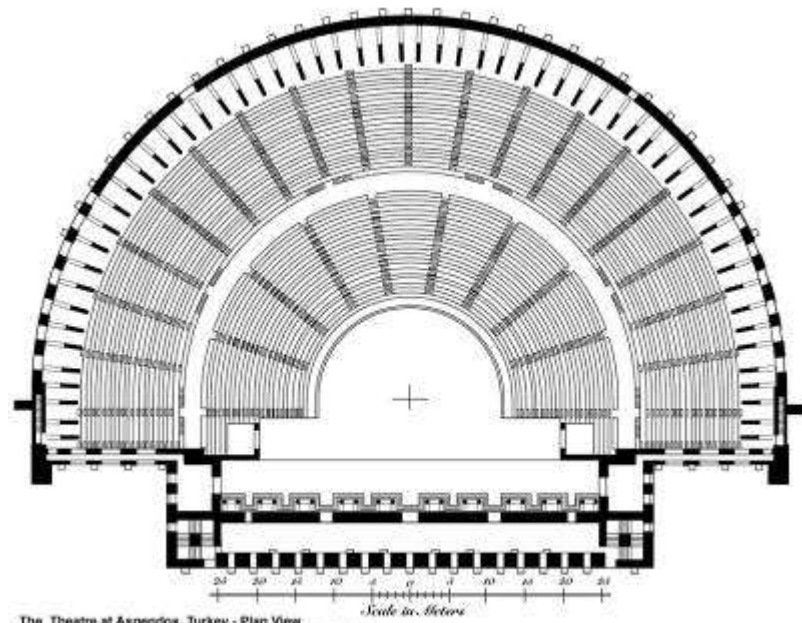

The Theatre at Aspendos, Turkey - Plan View
Date of Construction: ca. 160 AD - Seating Capacity: 15,000
Theatron: 99w X 73 meters - 325w X 240 feet / Orchestra: 24w X 20 meters - 79w X 66 feet / Stage: 49.5w X 7 meters - 162w X 23 feet
(approximate measurements based on reconstruction drawing)





SIDE (Antalya): MS 2. yy.la tarihlenen tiyatro tonozlu temeller üzerine oturtulmuştur. Skene arkasındaki yer alan agora ile birlikte theatronun yerleştirildiği tonozlu ve iki katlı konstrüksiyonun Side'nin kuzey-güney yönlü caddesine dayanması, halkın rahatlıkla ve kısa zamanda yapıya girip çıkmasını sağlamıştı. Ancak theatronun yarım daireyi aşan şekli Hellenistik geleneğe uygundur. Sahne binası üç katlı ve auditorium ile aynı yüksekliktedir

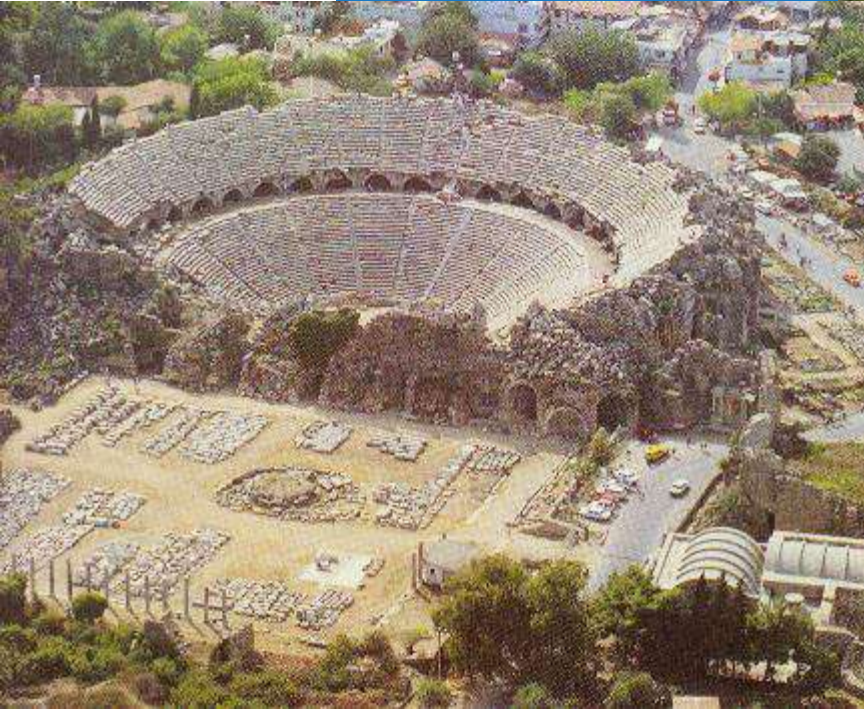
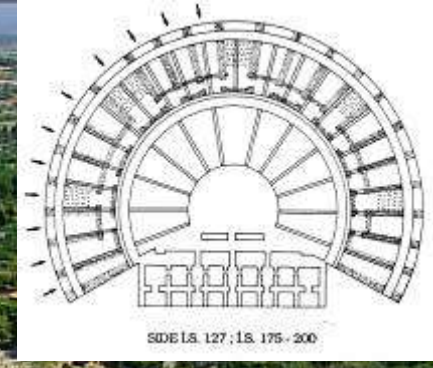

Perge Tiyatrosu

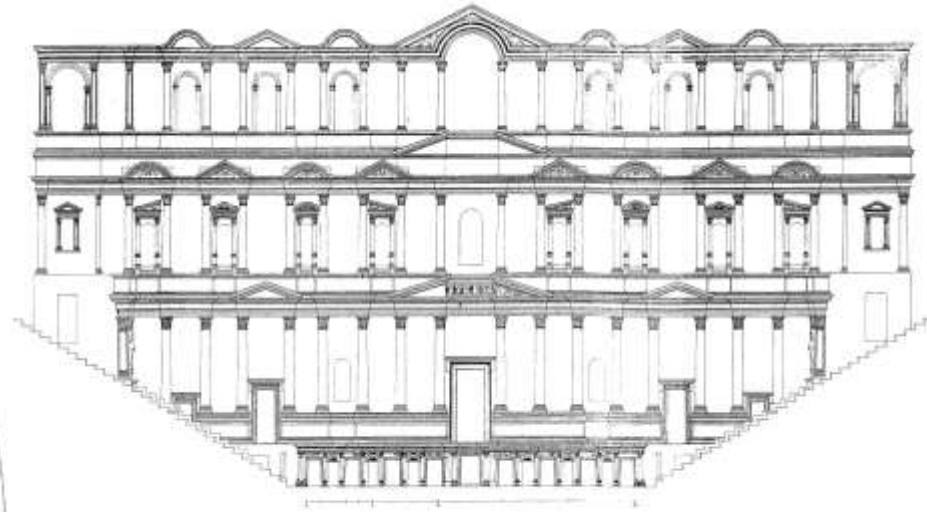
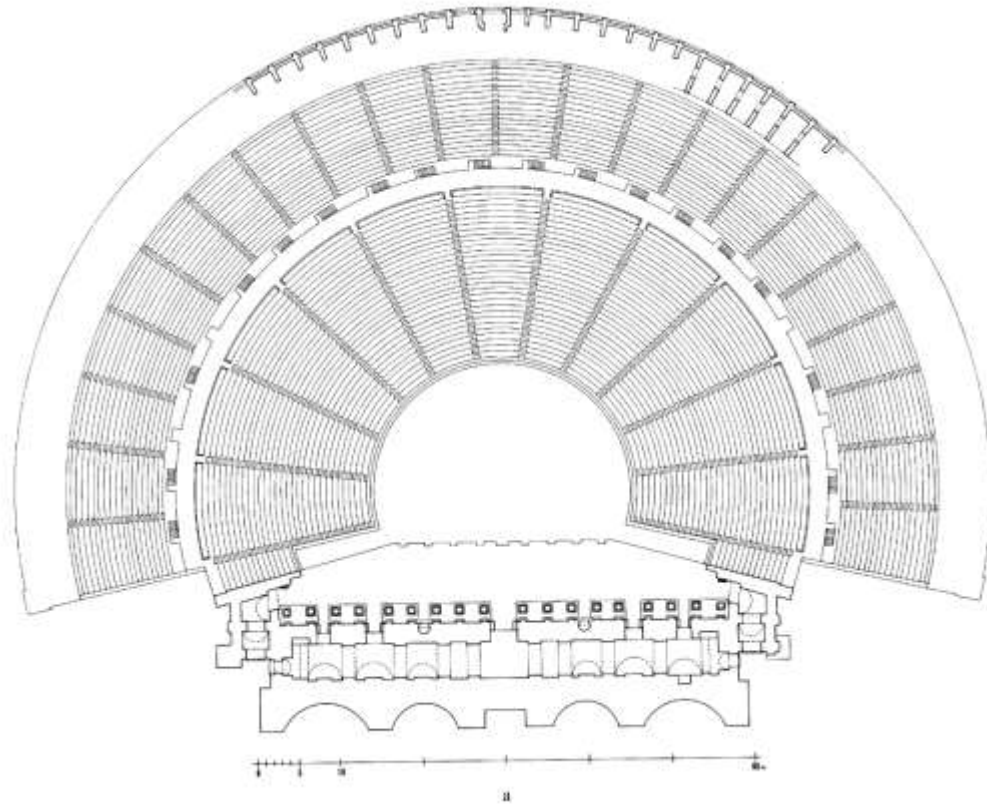

Rekonstruktion der scenae frons des Theaters von Perge (nach A. Öntürk [2000] Taf. 4)

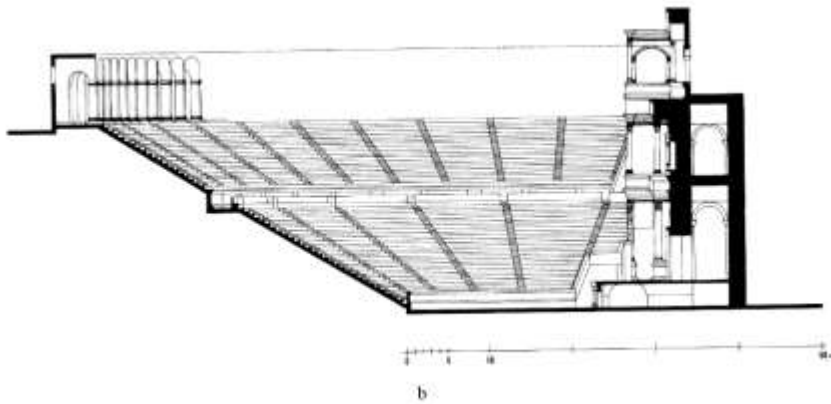

MYRA (Demre-Antalya):
Oldukça iyi korunmuş
durumdaki Roma dönemi
tiyatrosu Hellen tarzında
yamaçta inşa edilmiştir.
10.000 seyirci kapasitelidir.

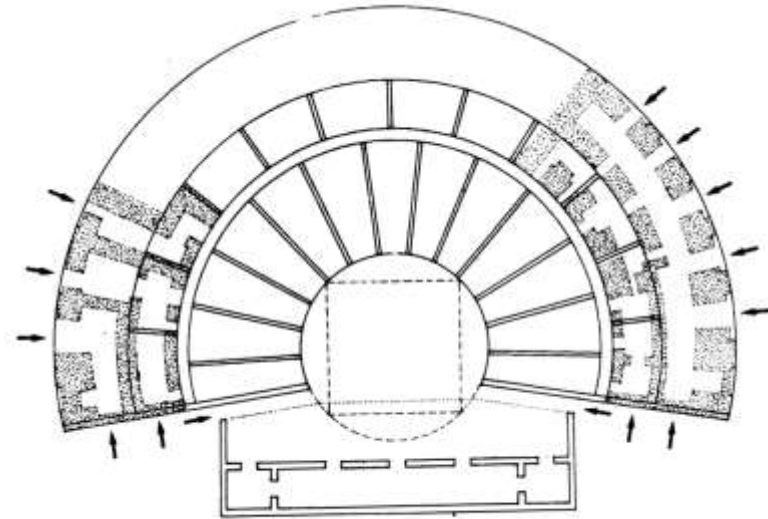

MYRA İ.S. 141 - 150 ; İ.S. 300

AUGUSTUS M.Ö.27 - M.S.14

➤ Cibyra	Cavea	(M.Ö.27-M.S.14)
➤ Alinda	Sahne II	(M.Ö.27-M.S.14)
➤ Alabanda	Tiyatro I	(M.Ö.27-M.S.14)
➤ Rhodiapolis	Sahne II	(M.Ö.27-M.S.14)
➤ Telmessus	Tiyatro	(M.Ö.27-M.S.14)
➤ Termessus	Cavea II, Sahne	(M.Ö.27-M.S.14)
➤ Tlos	Cavea I	(M.Ö.25-M.S.1)
➤ Prusias	Tiyatro	(M.Ö.10-M.S.20)
➤ Iasus	Cavea II ve Sahne II	(M.S.1-M.S.25)

TİBERİUS 14 - 37 / CALİGULA 37 - 41

➤ Patara	Cavea I	(14-37)
➤ Nysa	Tiyatro	(25-50)
➤ Cibyra	Stadyum	(25-50)
➤ Magnesia	Sahne II	(25-50)

CLAUDIUS 41 - 54

➤ Cibrya	Cavea II (Diazoma)	(41-54)
➤ Tralles	Tiyatro	(± 50)
➤ Kaunos	Cavea II, Sahne	(± 50)
➤ Aezani	Tiyatro I	(50-75)

NERO 54 - 68

➤ Ephesus	Sahne II (Birinci sıra tarihi) (66)
-----------	-------------------------------------

VESPASIANUS 69 – 79 / TITUS 79 – 81 / DOMITIANUS 81 – 96 / NERVA 96 - 98

➤ Perge	Tiyatro	(71-120)
➤ Miletus	Cavea II, Sahne V	(75-100)
➤ Ephesus	Kuzey Analemma	(92)

TRAIANUS 98 - 117

➤ Ephesus Güney Kanat ve II. Diazoma (102-112)

HADRIANUS 117 - 138

➤ Hierapolis Tiyatro (117-137)

➤ Side Cavea (± 120)

➤ Patara Sahne, Üst Cavea (130-147)

ANTONINUS PIUS 138 - 161

➤ Aspendus Tiyatro (139-168)

➤ Ephesus Proskenion III (140-144)

Üst Oturma Yerleri Velarium

➤ Limyra Onarımlar (141-150)

➤ Tlos Onarımlar (141-150)

➤ Myra Onarımlar (141-150)

ANTONINUS PIUS 138 – 161 / MARCUS AURELIUS 161 – 180
COMMODUS 180 – 193 / SEPTIMIUS SEVERUS 193 – 211
CARACALLA 198 – 217 / MACRINUS 217 – 218
ELAGABALUS 218 – 222 / SEVERUS ALEXANDER 222 - 235

➤ Ephesus	Sahne III	(150-210)
➤ Kaunos	Sahne II	(150-200)
➤ Miletus	Cavea III (Üst Sıra)	(169-180)
➤ Sagalassus	Tiyatro	(175-200)
➤ Side	Sahne II	(175-200)
➤ Termessus	Sahne II	(175-200)
➤ Iasus	Sahne III	(190-210)
➤ Prusias	Sahne II	(190-210)
➤ Cibyra	Cavea III (?), Sahne	(± 200)
➤ Perge	Cavea II (Rampalar, Galeri)	(± 200)
➤ Nysa	Sahne II	(± 200)
➤ Ephesus	Velarium, vb	(200-210)
➤ Myra	Tiyatro	(200-225)
➤ Termessus	Cavea III (Tribunal)	(200-225)
➤ Hierapolis	Sahne II	(204-211)

TRAIANUS DECIUS 249 - 251

➤ Limyra	Cavea ve Sahne	(± 250)
➤ Antiphellus	Cavea II	(± 250)
➤ Tlos	Cavea II ve Sahne	(± 250)
➤ Aezani	Cavea II ve Sahne II	(± 250)
➤ Aezani	Stadyum	(± 250)
➤ Perge	Sahne Çukuru	(± 250)
➤ Ephesus	Sahne Çukuru, Summa Cavea	(± 250)
➤ Priene	Sahne III	(250)

Erken Hıristiyanlık Dönemine kadar antik kentlerin en önemli yapıları olan tiyatrolar, Hıristiyanlığın yaygınlaşmasıyla birlikte görkemini yitirmiştir. Tek tanrılı yeni dinin ilk inananları, Hıristiyanlığın yasak olduğu Roma Dönemi'nde tiyatrolardaki vahşi gösterilere acımasızca malzeme olmuşlardır. Sonuçta, yüzyıllarca çekilen zulüm ve acıların simgesi haline gelen anıtsal yapılara nefret duyan halk onları terk etti, lanetledi ve bazen de tahrip etti. Varlık sebebini yitiren tiyatrolar, MS 5. yüzyıldan itibaren yavaş yavaş ortadan kalkmaya başladı, MS 7. yüzyılda ise tamamen terk edildi.

AMPHİTİYATROLAR

Roma Dönemi'ne özgü bir yapı türü olan amphitiyatrolar kelime olarak çift taraflı seyirlik (theatron) anlamını taşımaktadır. Roma'daki Colosseum'da görüldüğü gibi orkestra tamamen oturma sıraları ile çevrelenmektedir.

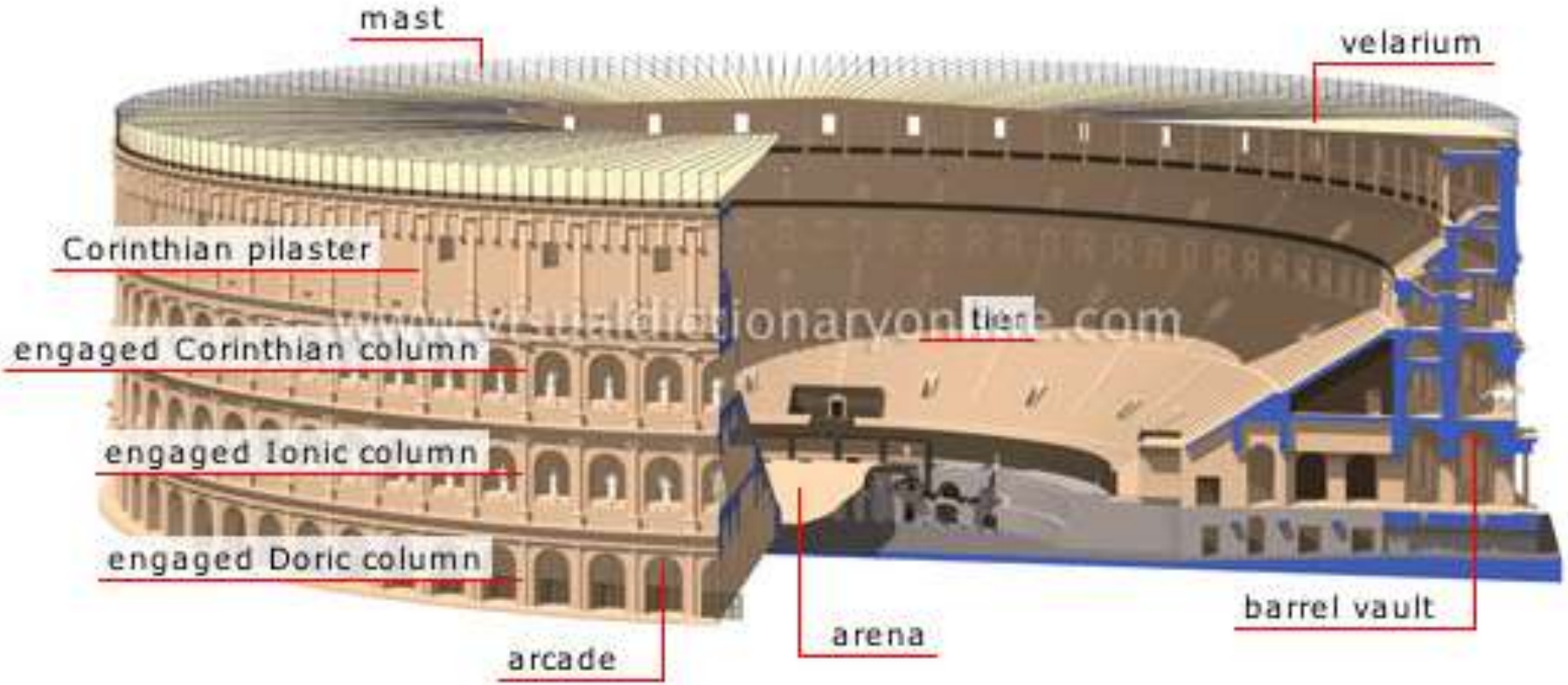





**Roma'daki Flaviuslar
Dönemi Amphitiyatrosu
(Colosseum)**







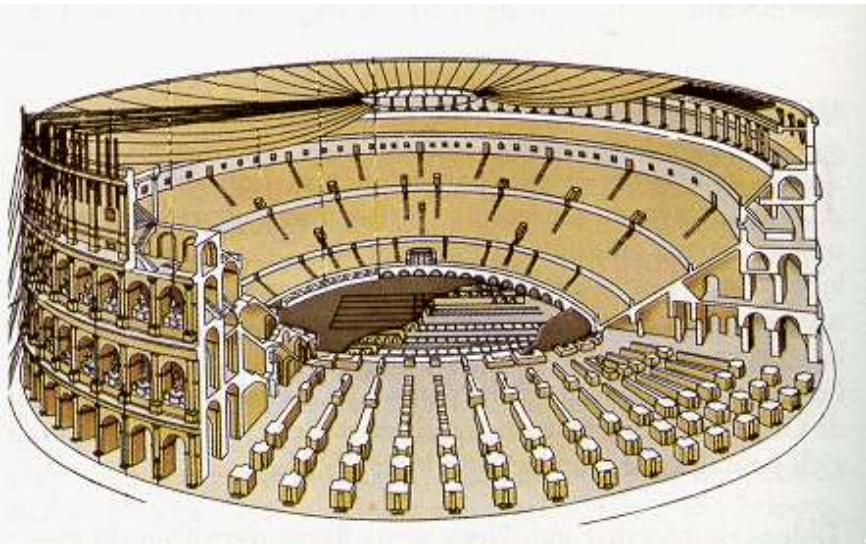

Güney İtalya: Pompeii Amphitiyatrosu

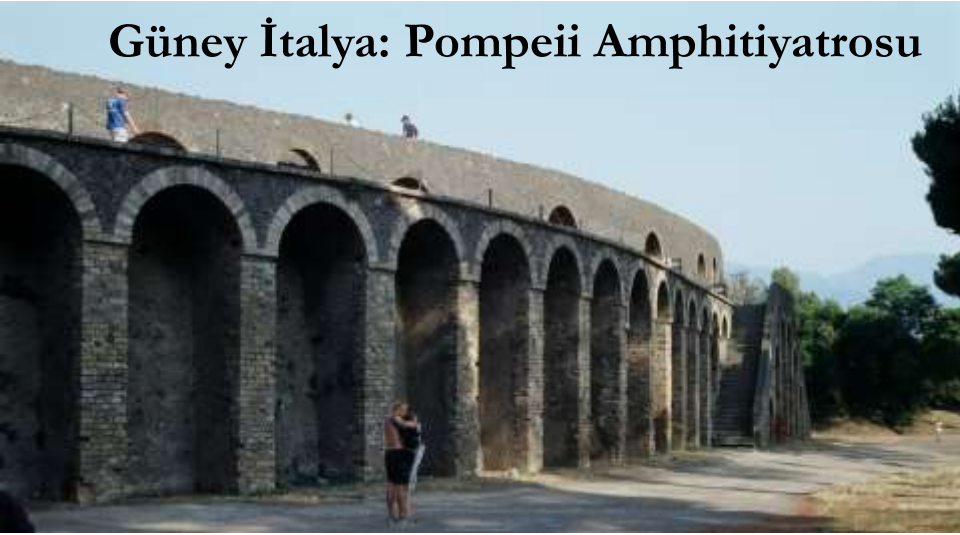

Kuzey İtalya: Verona Amphitiyatrosu



**Nimes 'Nemausus' Amphitiyatrosu MS.1.yy. sonu
133x101 m**





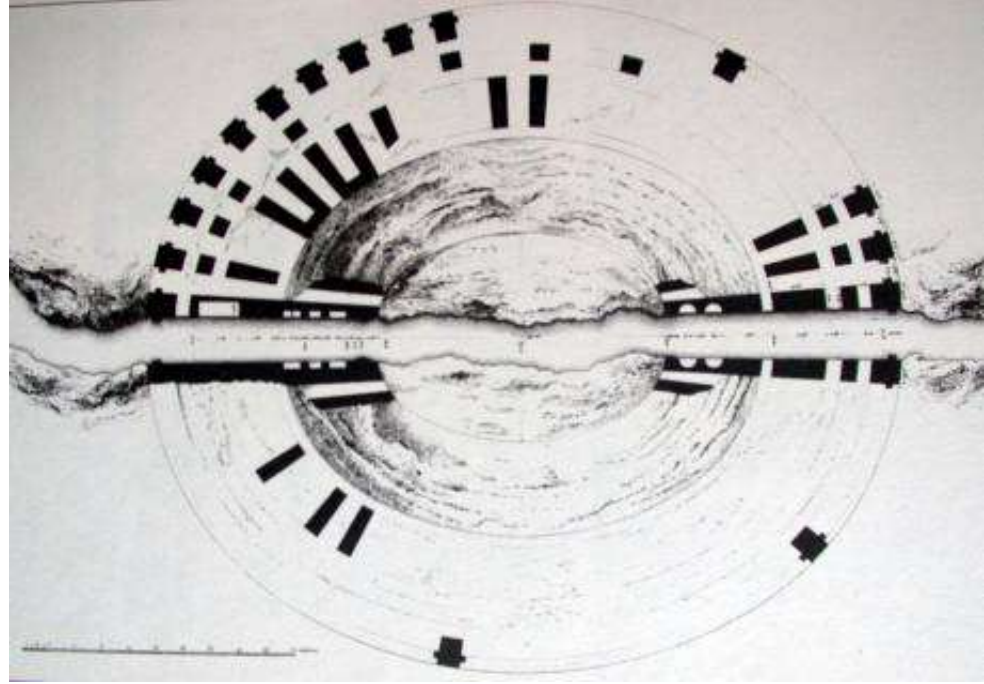

Pergamon Amphitiatro

ROUGH SKETCH OF
THE SITE OF CYZICUS
AND PROBABLE CHANNEL
BY
ROBERT DE RUSTAFJELL FRSG
2 JULY 1901



- EXPLANATIONS**
- Visible ruins
 - Ruins under brushwood
 - Traces of masonry
 - Road and mountain trails
 - Rivers & Streams
 - Mulberry and fruit trees
 - Vineyards
 - Hypothetic limits
 - Sand

Kyzikos Amphitiyatro

E.N.E. Prevailing Winds

Scale 0 100 200 300 400 500

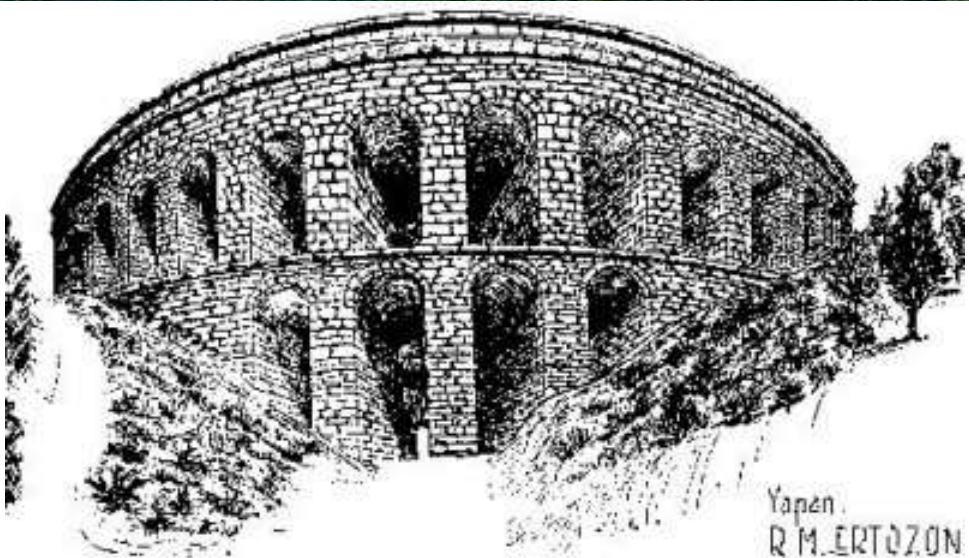

Yapın.
R. M. ERTÖZÜN

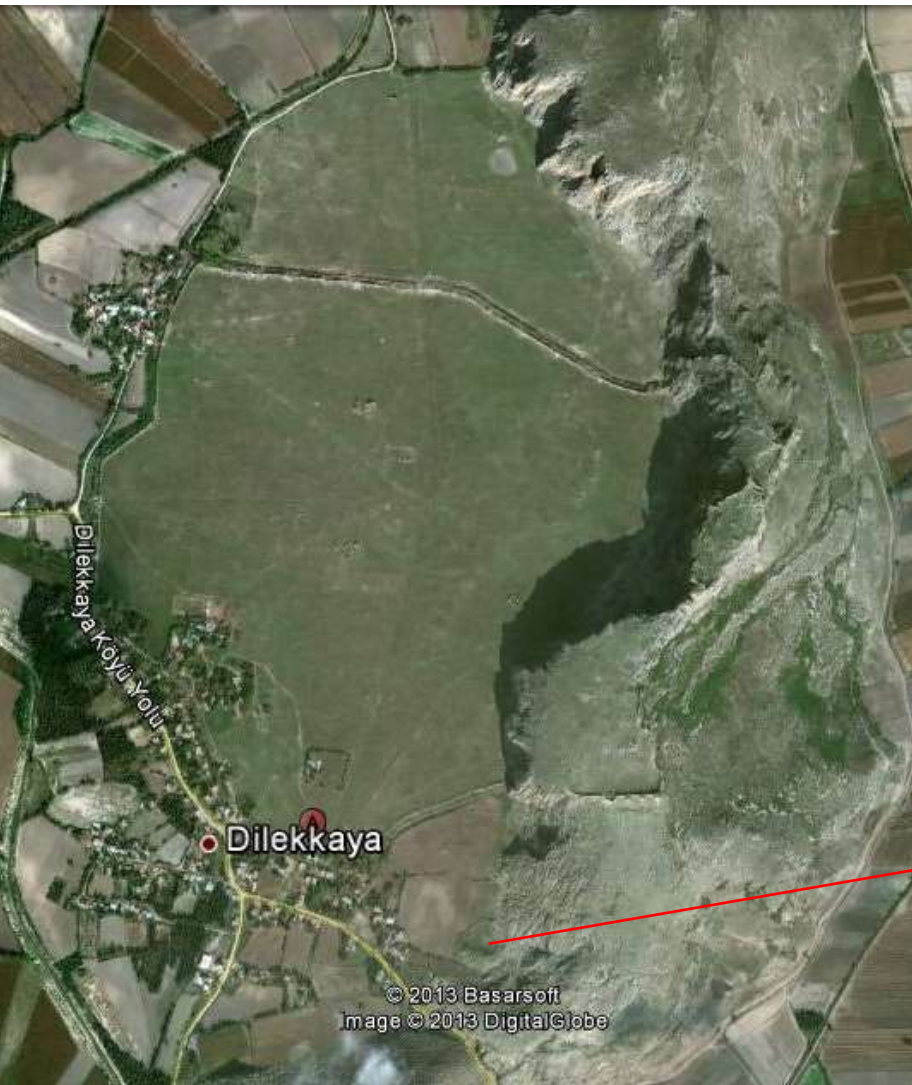

Anazarbos, Amphitiyatro

