

KLA 220
ANADOLU TARİHİ COĞRAFYASI

2. Hafta

Mimari, Yapım Teknikleri, Düzenler, Terminoloji

Mimari nedir?

Mimarlık, insanların yaşamalarını kolaylařtırmak ve barınma, dinlenme, alıřma, eęlenme gibi eylemlerini srdrebilmelerini saęlamak zere gerekli mekanları, iřlevsel gereksinimleri ekonomik ve teknik olanaklarla baędařtırarak estetik yaratıcılıkla inřa etme sanatı olan YAPI SANATI'dır.

Vitruvius'a göre Mimarlığın Temel İlkeleri

Mimarlık, düzen, düzenleme, armoni, bakışım, uygunluk ve ekonomiye dayanır.

Düzen: Bir yapıtın bölümlerinin herbirine gereken önemi vererek tümünün oranlarına bir uyum getirir.

Düzenleme: Mimari öğelerin yerli yerine konmasını ve yapıtın özelliğine göre yapılan ayarlamalardır.

Armoni: Öğelerin ayarlamalarındaki güzellik ve uygunluktur.

Bakışım: Yapının öğeleri arasındaki doğru uyum ve ölçüt, öğeler arasındaki bağlantı.

Uygunluk: Bir yapıt, yetkinlikle, geçerli ilkelere göre yapıldığında beliren biçem mükemmelliğidir.

Ekonomi: Malzemelerin ve arazinin doğru kullanımının yanında, yapım işlerinde maliyetin ölçülü ve akıllıca olmasını içerir.

YAPIM TEKNİKLERİ

**Kerpiç ve ahşap mimariden taş
mimariye geçiş**

**Kerpiç: Plinthos omai
İçine saman katılmış toprak
döğülür, su ile yoğurulup,
kalıplara dökülerek güneşte
kurutulurdu.**





Kerpiç ev kalıntısı
Elmalı

Xanthos, kerpiç duvar
kalıntısı
Hellenistik dönem





Bayraklı (Eski İzmir)



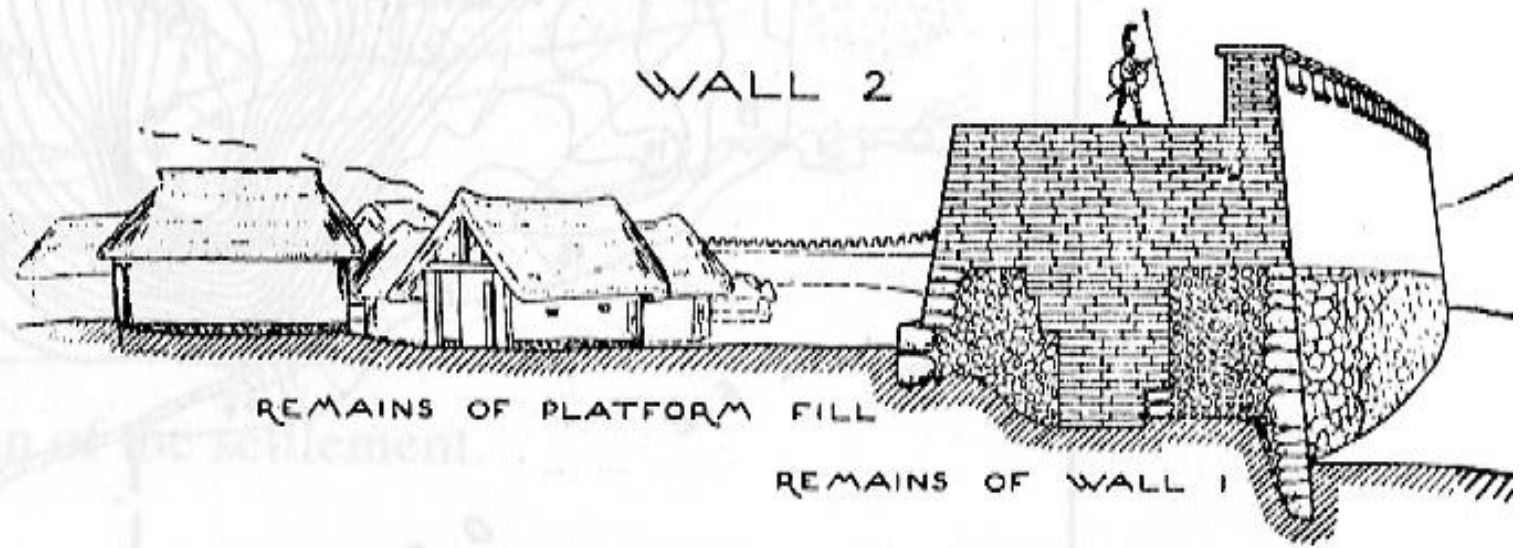
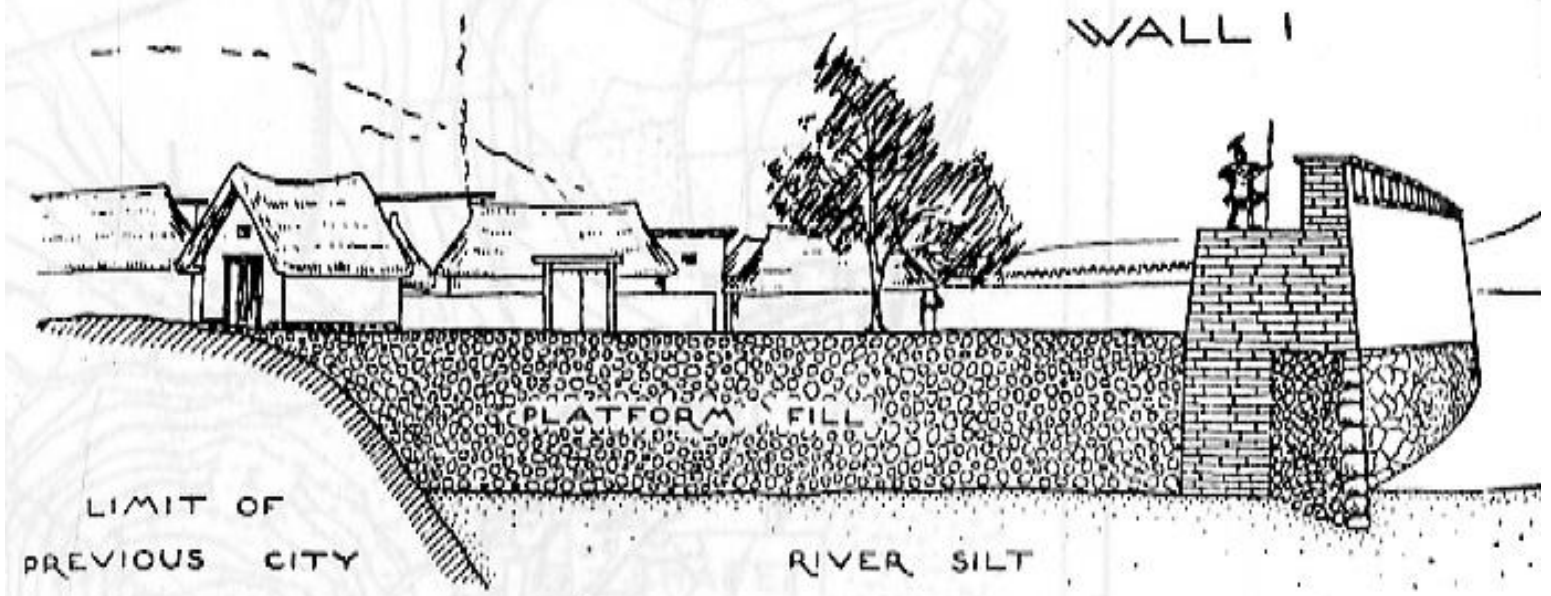







Pınara Kaya Mezarları









1.

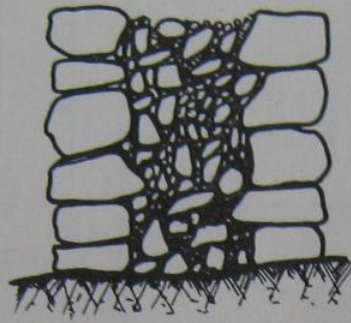

2.



Korint Surları



3.

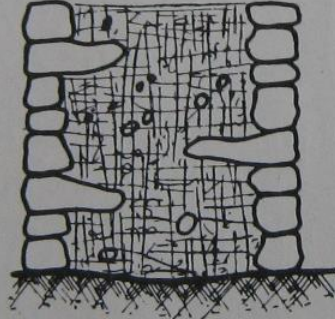

4.



1. SADE DOLGU
2. ÇİFT DUVAR ÖRGÜLÜ
3. AŦKILI
4. BÖLMELİ



A-A KESİTİ

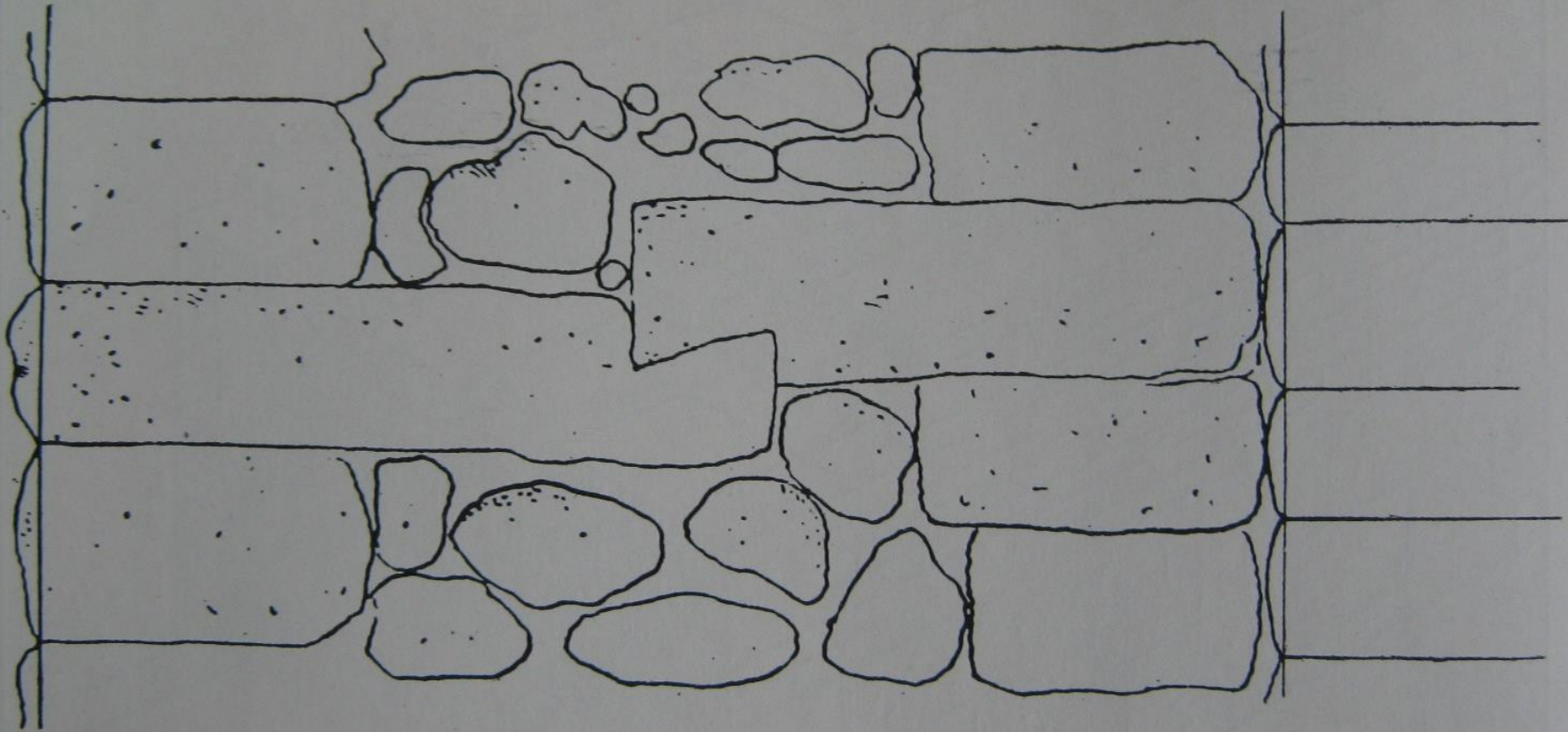

0

2.M



63. Assos. Dolgulu ve atkılı duvar örgüsü, kesit.

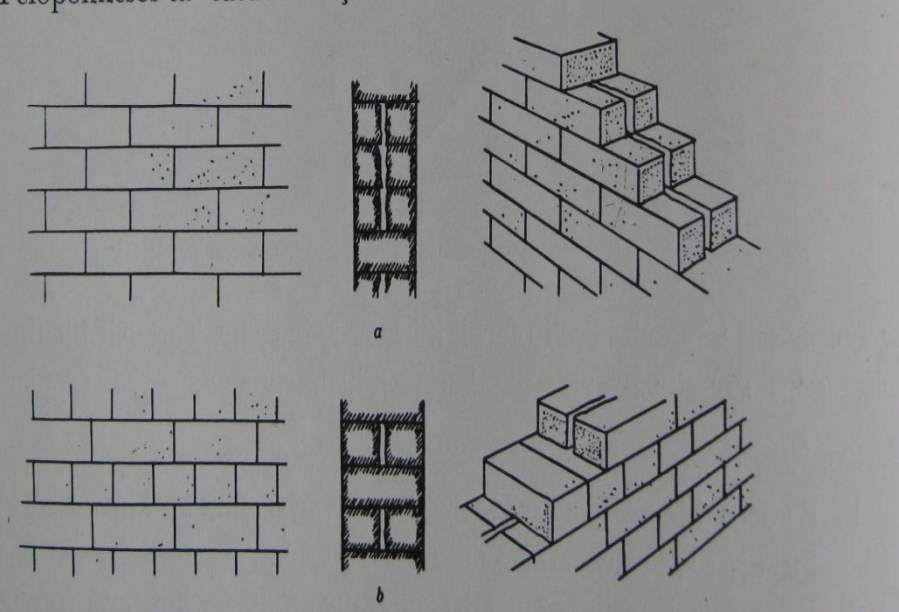

Dikdörtgen taş duvarlar. Isodomos örgü: a. iki boy taşla, b. tek boy taş

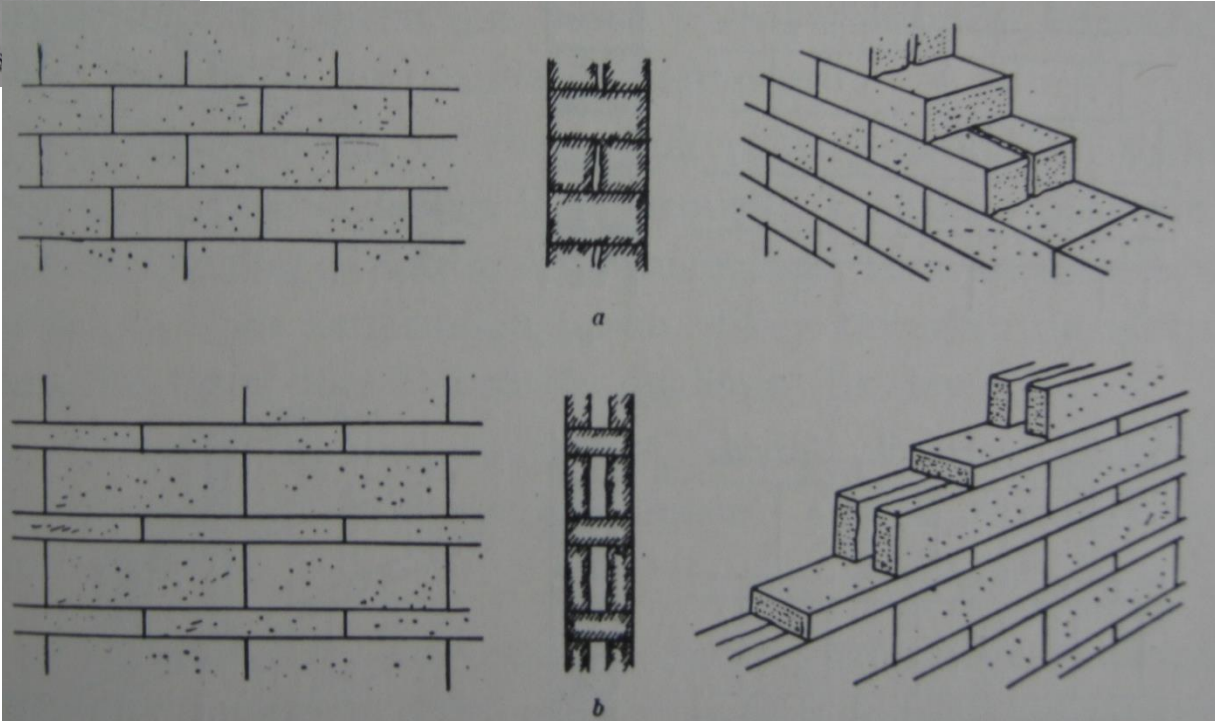

66. Dikdörtgen taş duvarlar. Isodomos (a) ve pseudo-isodomos (b) örgü.





14. Keramos, düz kenarlı çokgen örgü, Hellenistik çağ

ALINDA AGORA STOASI

Atkılı yalancı isodomik örgü



ASSOS KENT SURU

REKTAGONAL İSODOMİK ÖRGÜ



A1

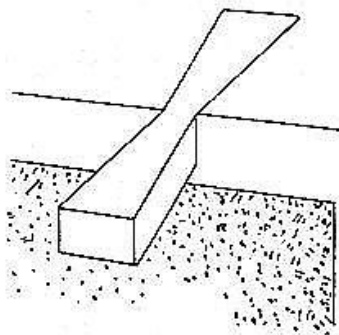

A2

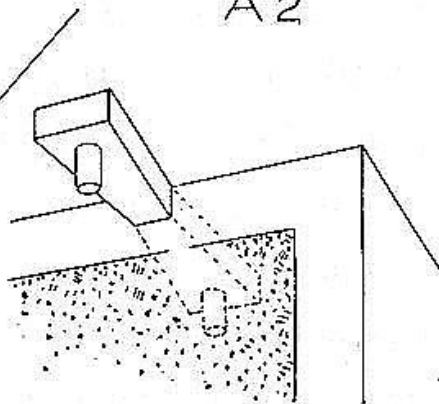

A3

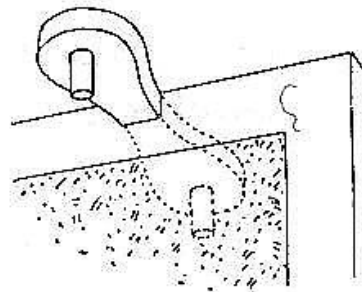

B1

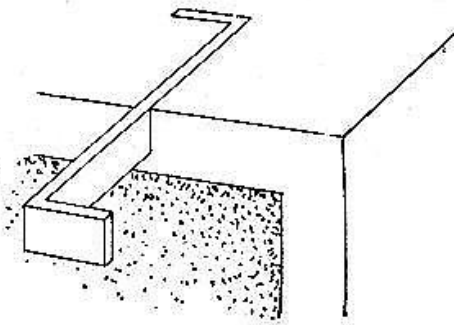

B2

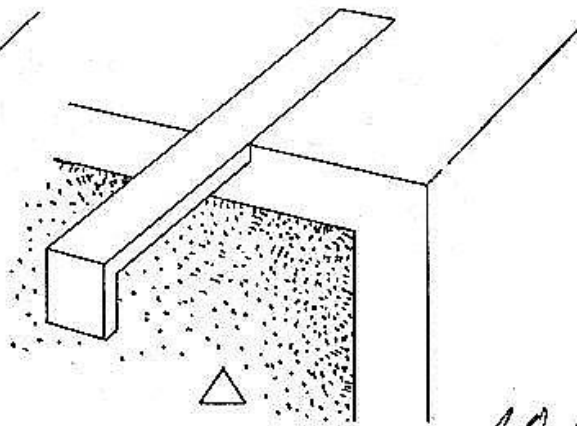
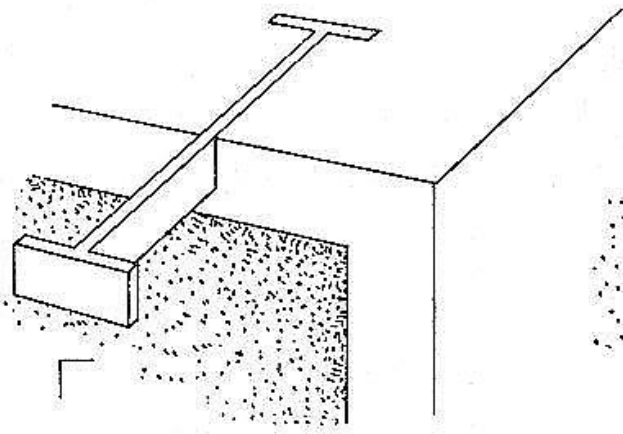
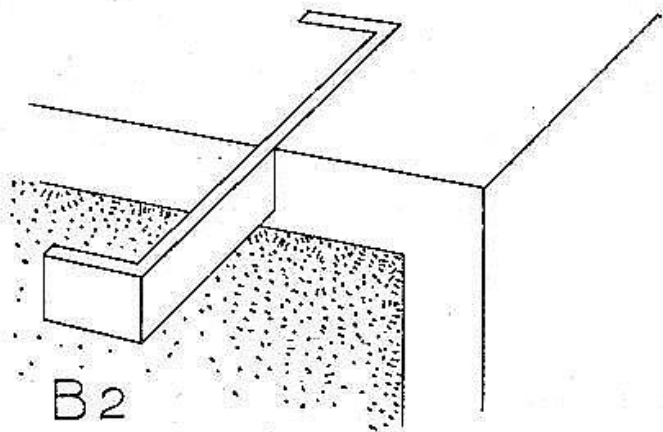

Alc.



KENET VE SAPLAMA
Xanthos, Leto Tapınađı



1 : Kırlangıç Kuyruđu kenet

2, 3 : Saplama - Dbel

4 : Kırlangıç Kuyruđu kenet sıkıřtırma kurřunuyla birlikte



Çanakkale, Apollon Smintheus



Delos, Athena Tapınağı

ANATHYROSIS



Aigina, Aphaia Tapınağı

**Atina
Hephaisteion**



**Halikarnassos,
Maussolleum**

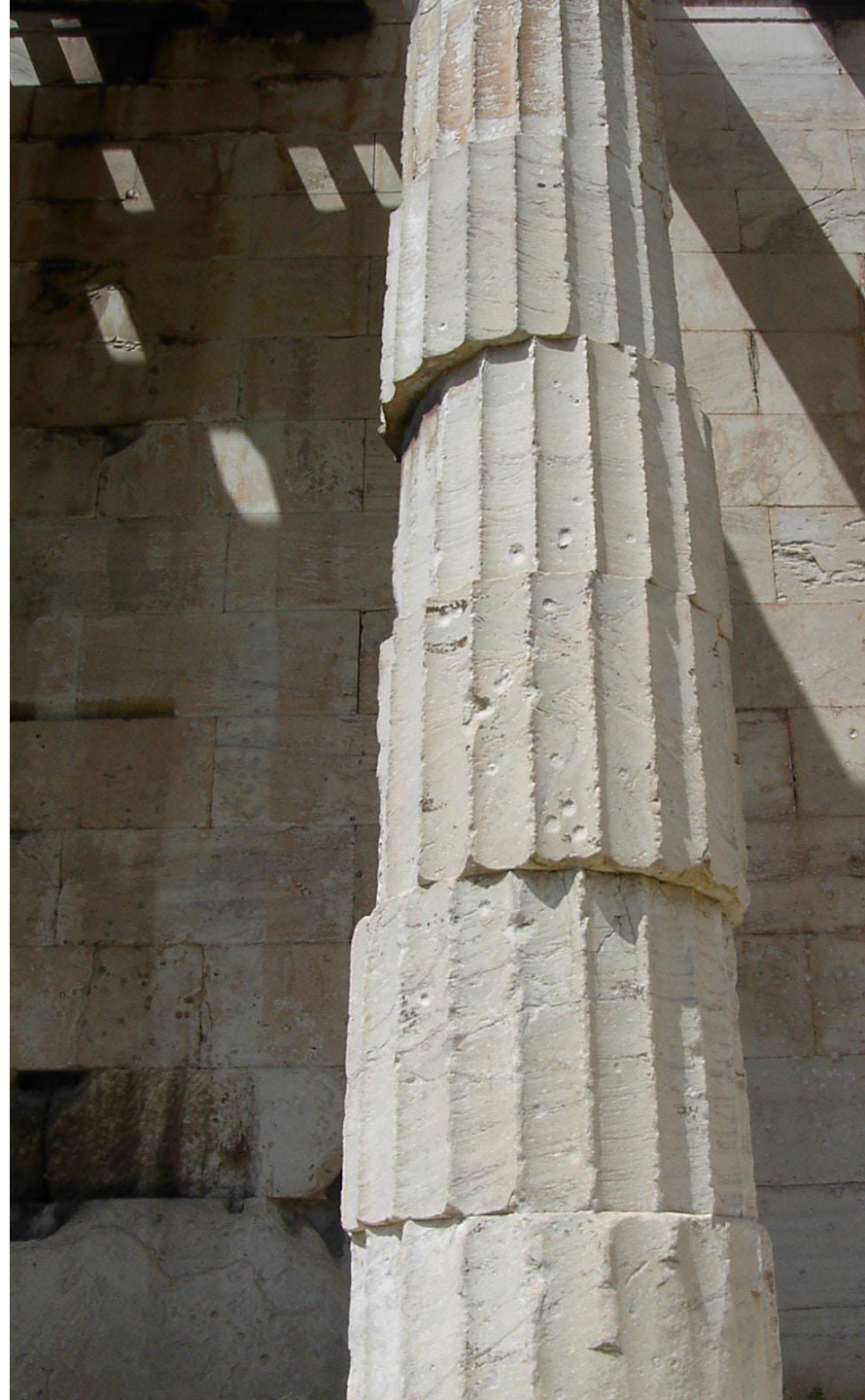

Başlıca Mimari Düzenlerdeki Başlık Tipleri

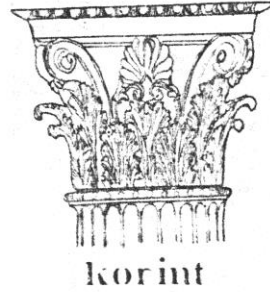
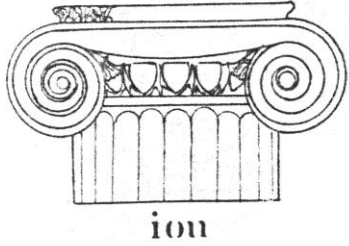
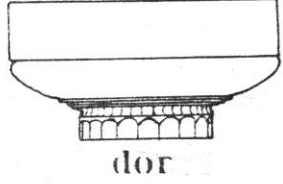

**Temel mimari düzenlerin başlangıcı
MÖ 8-7. yüzyıla dayanmaktadır.**

**Kıta Yunanistan'da Dor düzeni
gelişirken,**

**Batı Anadolu'da ve adalarda İon
düzeni gelişmiştir.**

**Aeol ve İon başlıkları Anadolu'da
yaratılmıştır.**

- DOR DÜZENİ
- İON DÜZENİ
- AEOL DÜZENİ
- KORİNTH DÜZENİ
- KOMPOZİT DÜZEN

Bayraklı Athena Tapınağı, MÖ 600



Abb. 46a, b Alt-Smyrna. Athenatempel. Volutenkapitell p. Rekonstruktionsvorschlag des Verfassers (Zeichnung: Murat Erdim)



Abb. 43 Alt-Smyrna. Athenatempel. Kapitell A. Tuffstein. Um 600 v. Chr. (Aufnahme und Zeichnung: Meral Matyas)

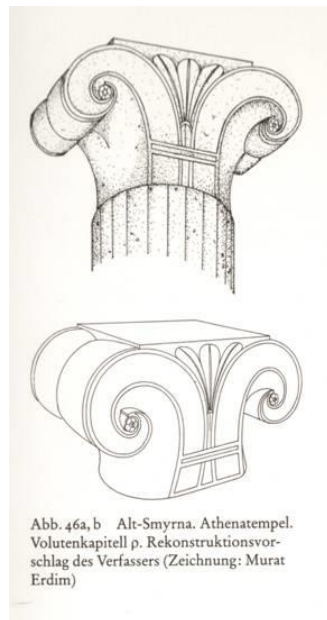
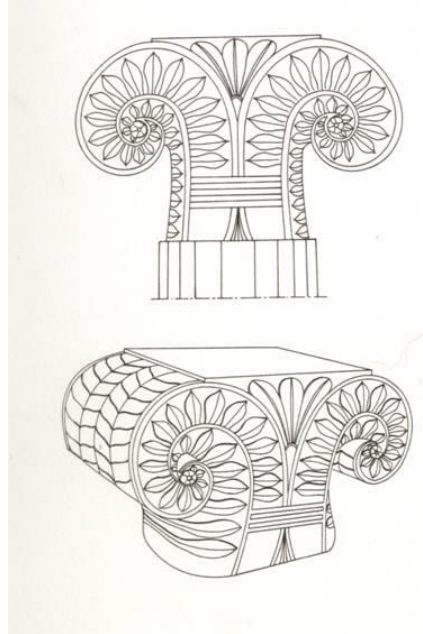

Abb. 44 Alt-Smyrna. Athenatempel. Kapitell B. Tuffstein. Um 600 v. Chr. Aus Dutzenden Fragmenten zusammengesetzt von Oksan Bingöl (Aufnahme und Zeichnung: Meral Matyas)



Abb. 45 Alt-Smyrna. Athenatempel. Kapitell C. Tuffstein. Um 600 v. Chr. Aus Dutzenden Fragmenten zusammengesetzt von Meral Matyas (Aufnahme und Zeichnung: Meral Matyas)



DOR DÜZENİ

- Mimari yapıların oluşturulmasında kullanılan bu düzen, esasen Kıta Yunanistan'da, kuzeydoğu Peloponnesos Bölgesi'ndeki ahşap yapılarda gelişmiştir.
- M.Ö. 8. – 7. yüzyıllarda bu yapı formu taş mimariye uygulanmıştır. Bu taş uygulamaya geçiş özellikle yeni yapılarda uygulanmıştır.
- Daha önceden var olan ahşap yapılarda zamanla ahşap elemanların taşla değiştirilmesine en iyi örneği Olympia'daki Hera Tapınağı sunar.
- Pausanias (15, 6, 1) Olympia'daki bu tapınağın Opisthodomos'unda ahşap bir sütun gördüğünü, diğer sütunların ise taştan olduğunu bildirmektedir.

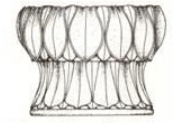
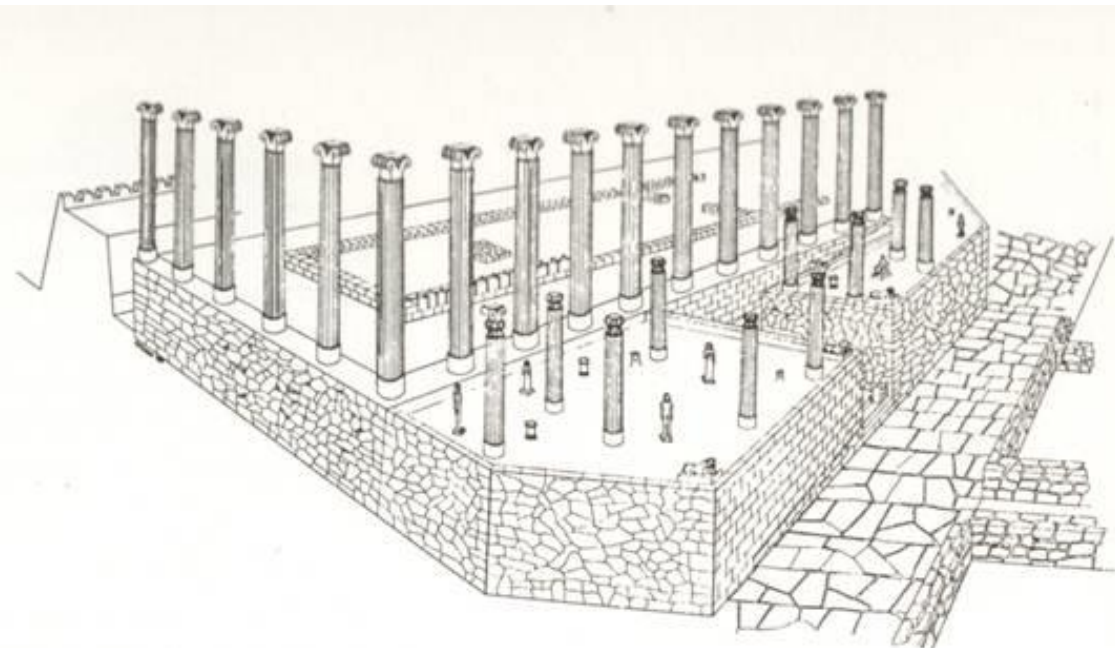
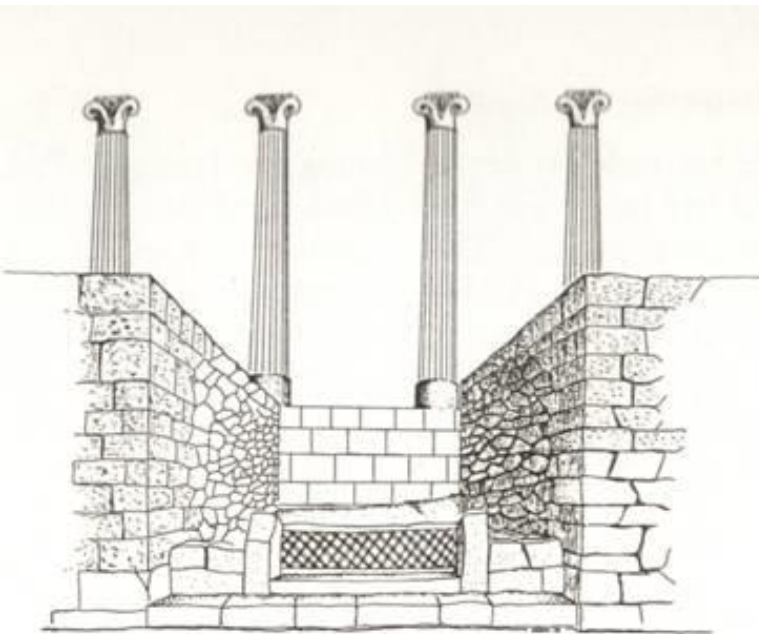
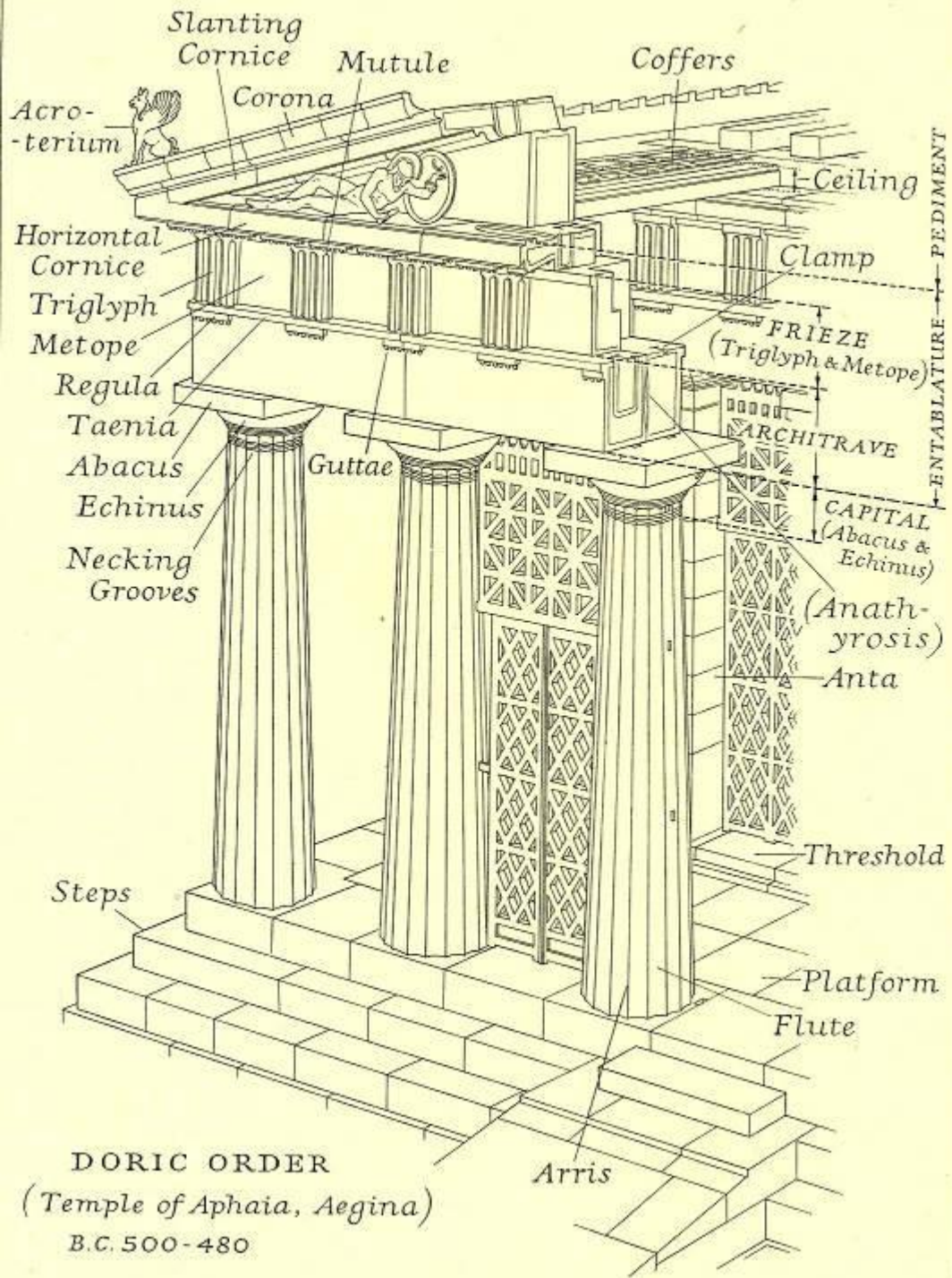

Stylobat üzerine kaidesiz oturan, bıçak ağızı şeklinde sütun yivleri olan, tepesi kesik ters koni başlıklı (ekhinus) düz arşitravlı, triglif-metop sırasından oluşan frizli; oldukça yalın ve güçlü görünümlü, Grek mimarlığının üç önemli düzeninden biri.

DOR DÜZENLİ TAPINAK

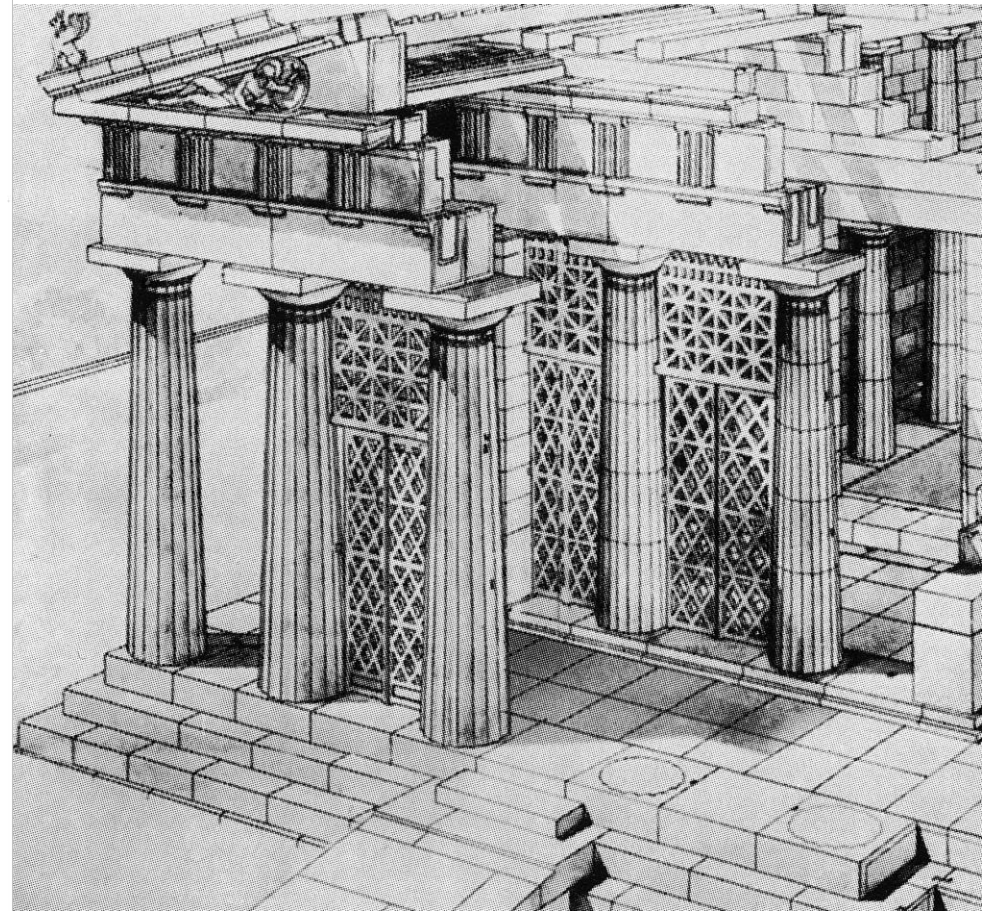
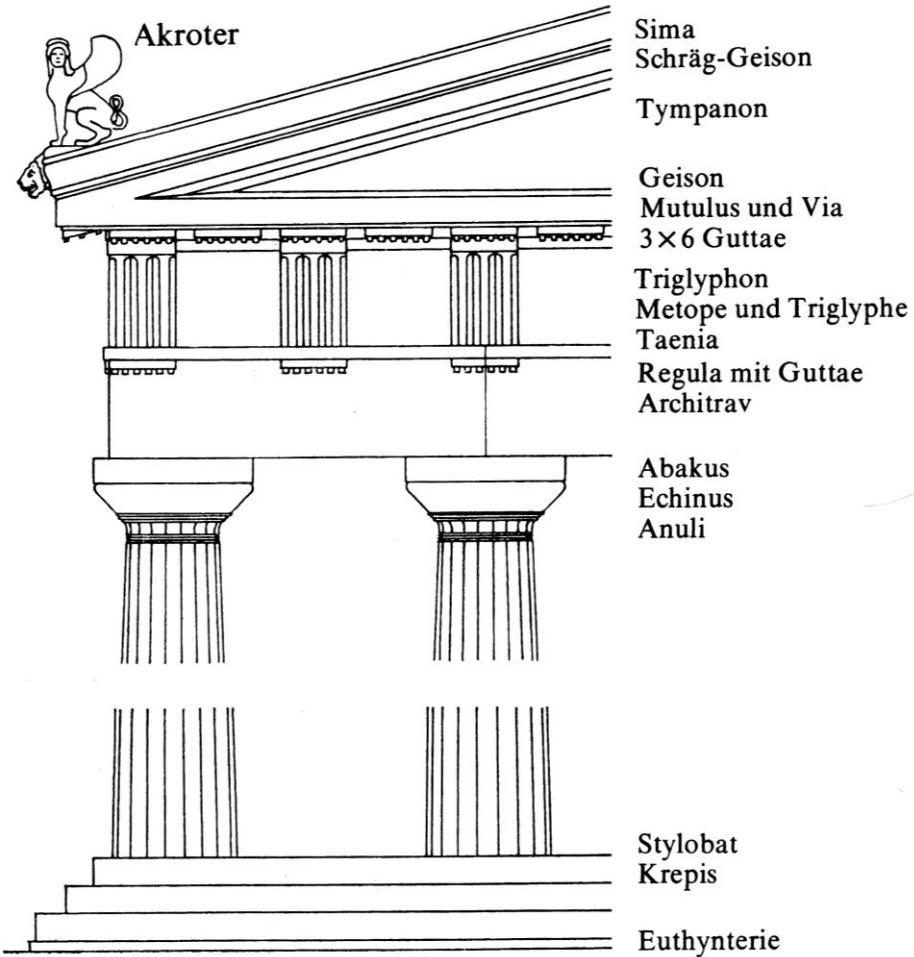

AEGINA APHAIA TAPINAĞI

DOR DÜZENİ TRİGLİF METOP

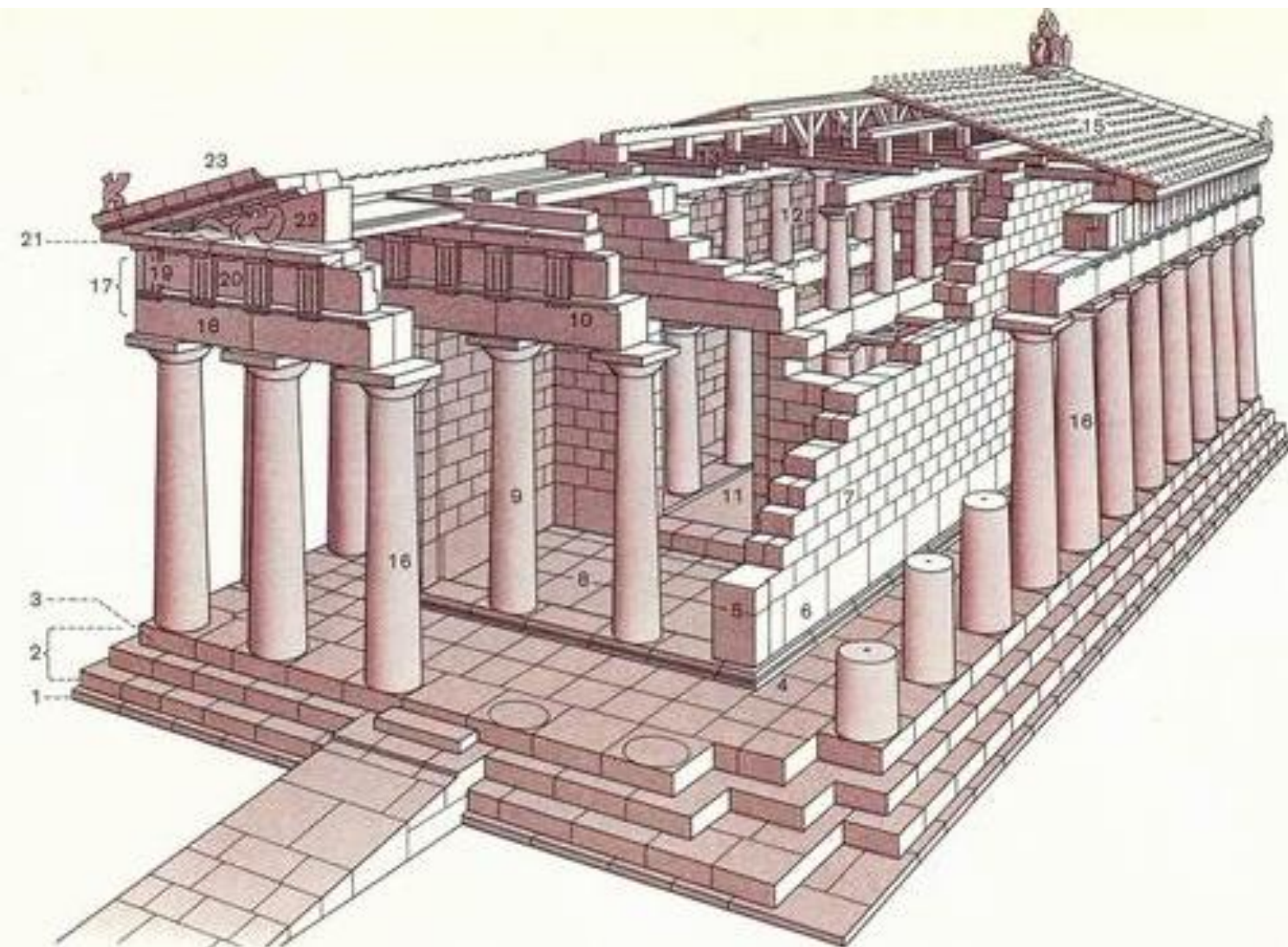

Unterbau

- 1 Euthynterie
- 2 Krepis
- 3 Stylobat

Naos

- 4 Sockel
- 5 Cellawand
- 6 Orthostaten
- 7 isodomes Mauerwerk
- 8 Vorhalle
- 9 Säulen in antis
- 10 Gebälk
- 11 Cella
- 12 innere Säulenstellung
- 13 Balkendecke
- 14 Dachstuhl
- 15 Dachdeckung

Ringhalle

- 16 Säulen
- 17 Gebälk
- 18 Architrav
- 19 Triglyphen
- 20 Metopen
- 21 Kranzgesims
- 22 Giebfeld
- 23 Giebelgesims

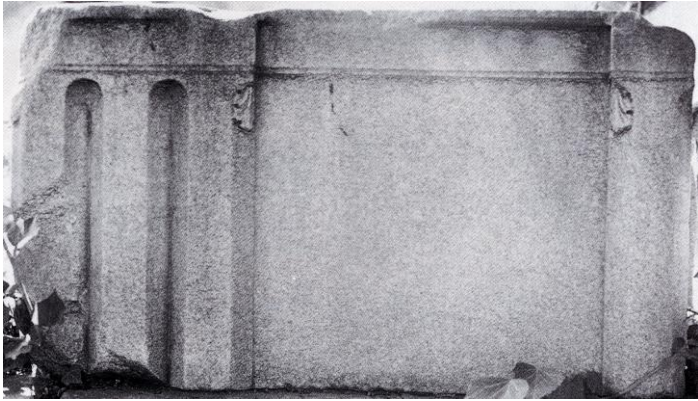

PARTHENON (M.Ö.447-432)



İON DÜZENİ

FUNDAMENT, EUTHYNTERIE, KREPIS, STYLOBAT, TOICHOBAT. s. dorische Ordnung.



Abb. 21: Ionische Ordnung, Tempel der Athena Polias in Priene, Schema



PRIENE ATHENA TAPINAĞI REKONSTRÜKSİYONU

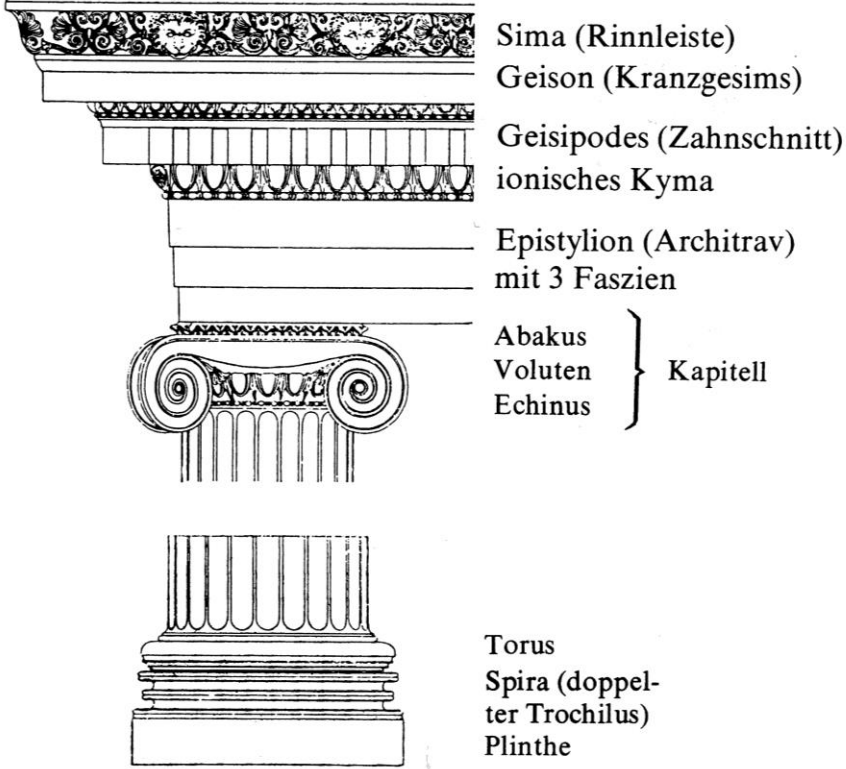
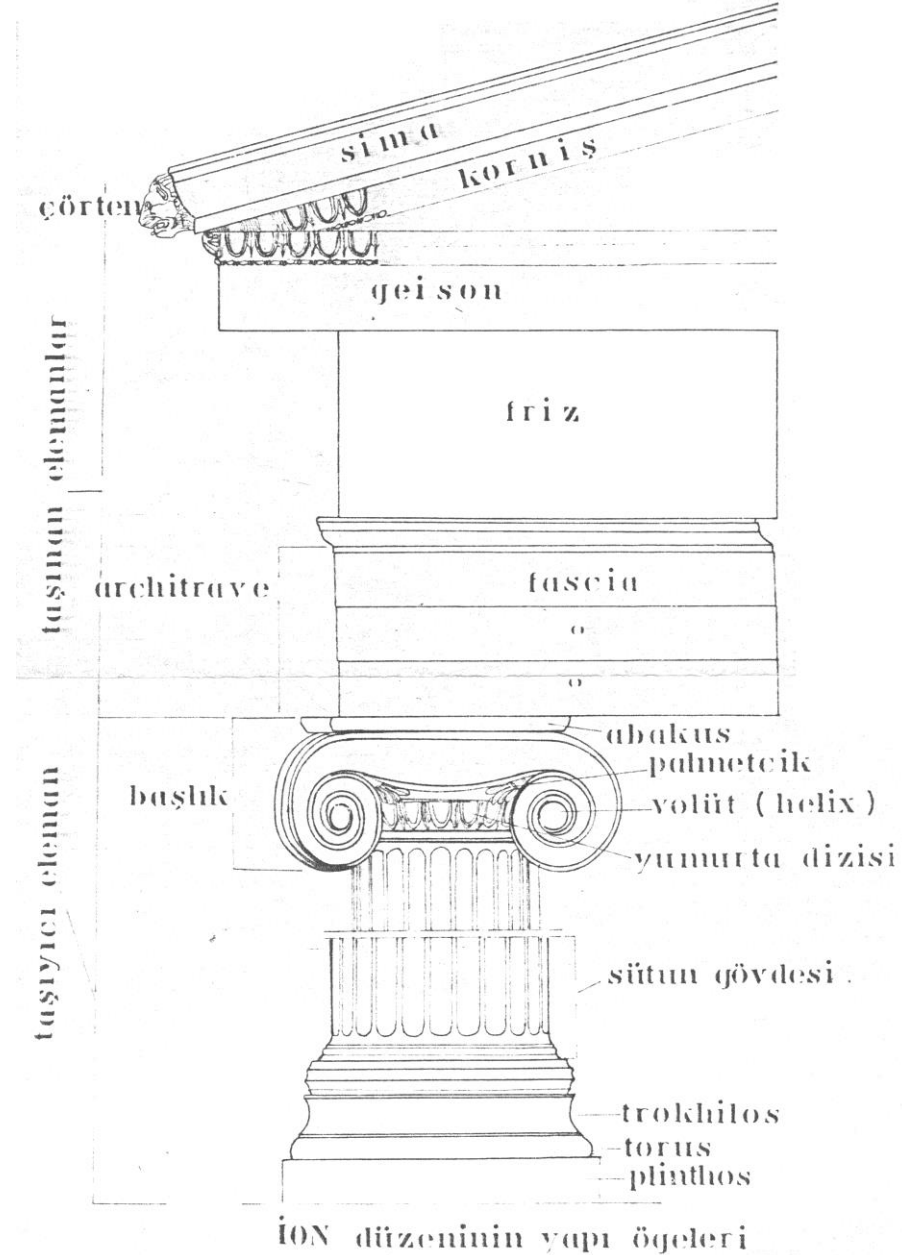
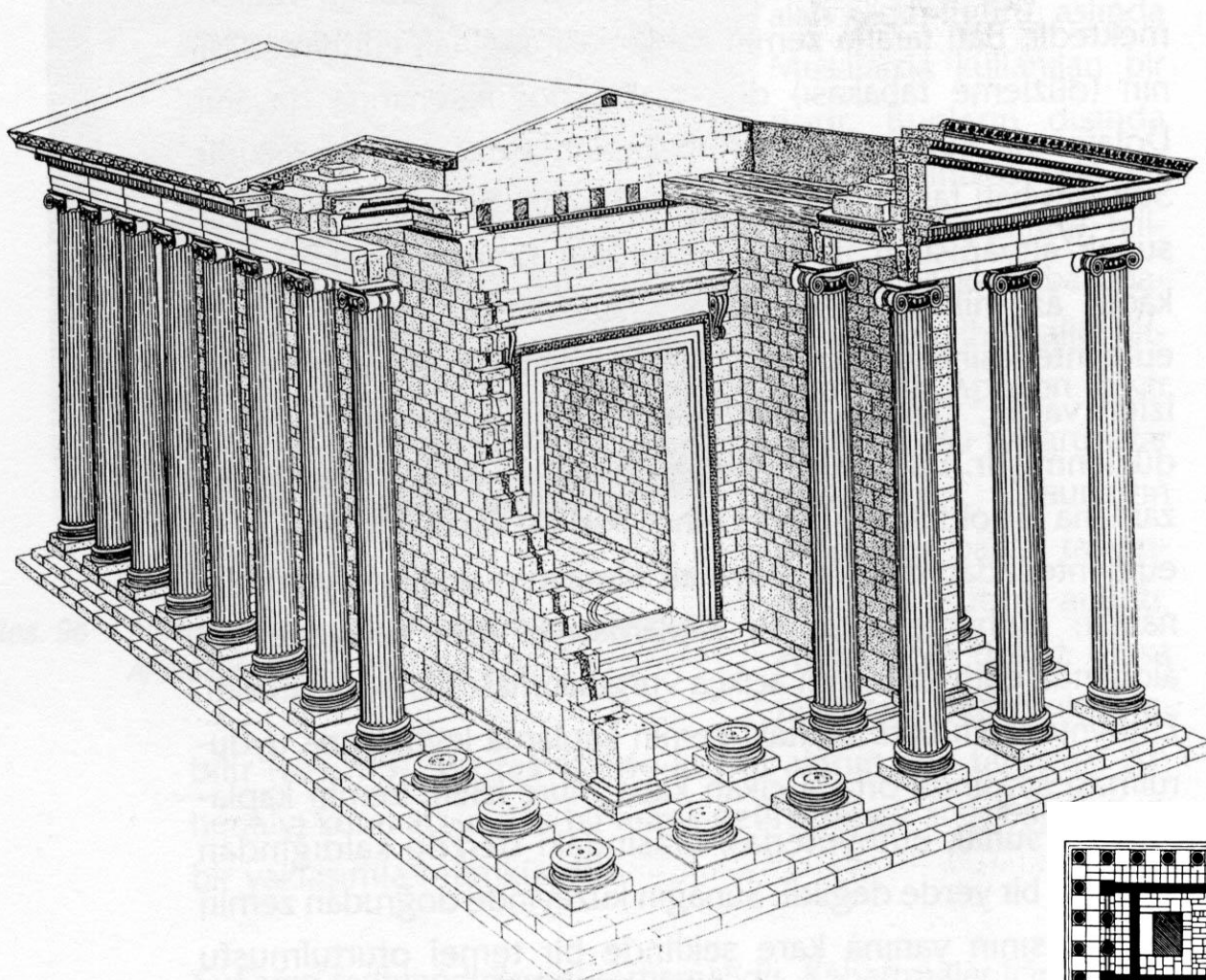

Res. 97 Athena Tapınağı. Güneydoğudan görüşünün isometrik rekonstrüksiyonu.

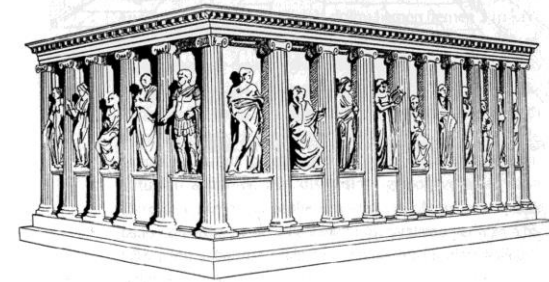

Res. 95 Athena Sunağı. Güneydoğudan görüşünün rekonstrüksiyonu.

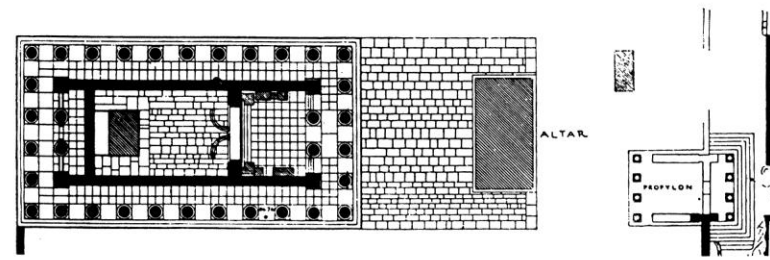

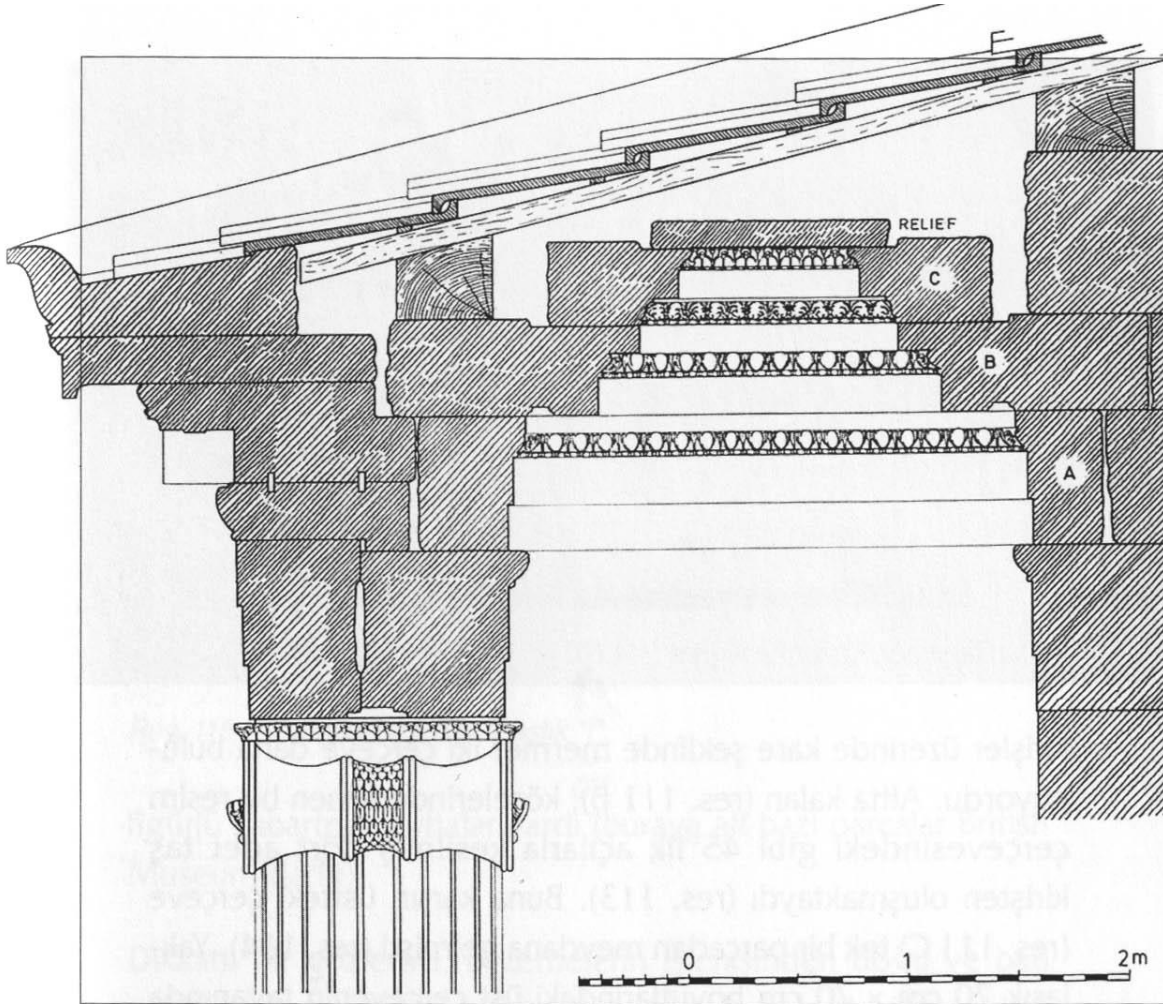

Res. 111 Athena Tapınağı. Saçaklık ve tavan kesitinin rekonstrüksiyonu.

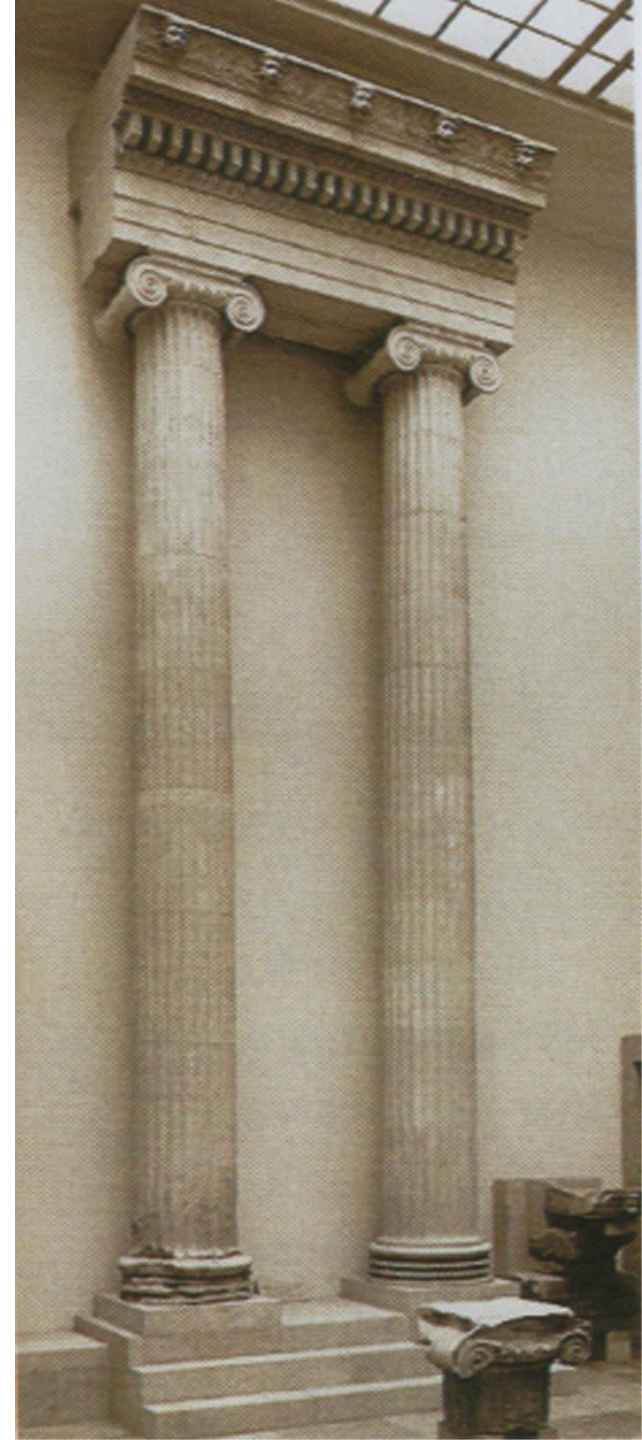

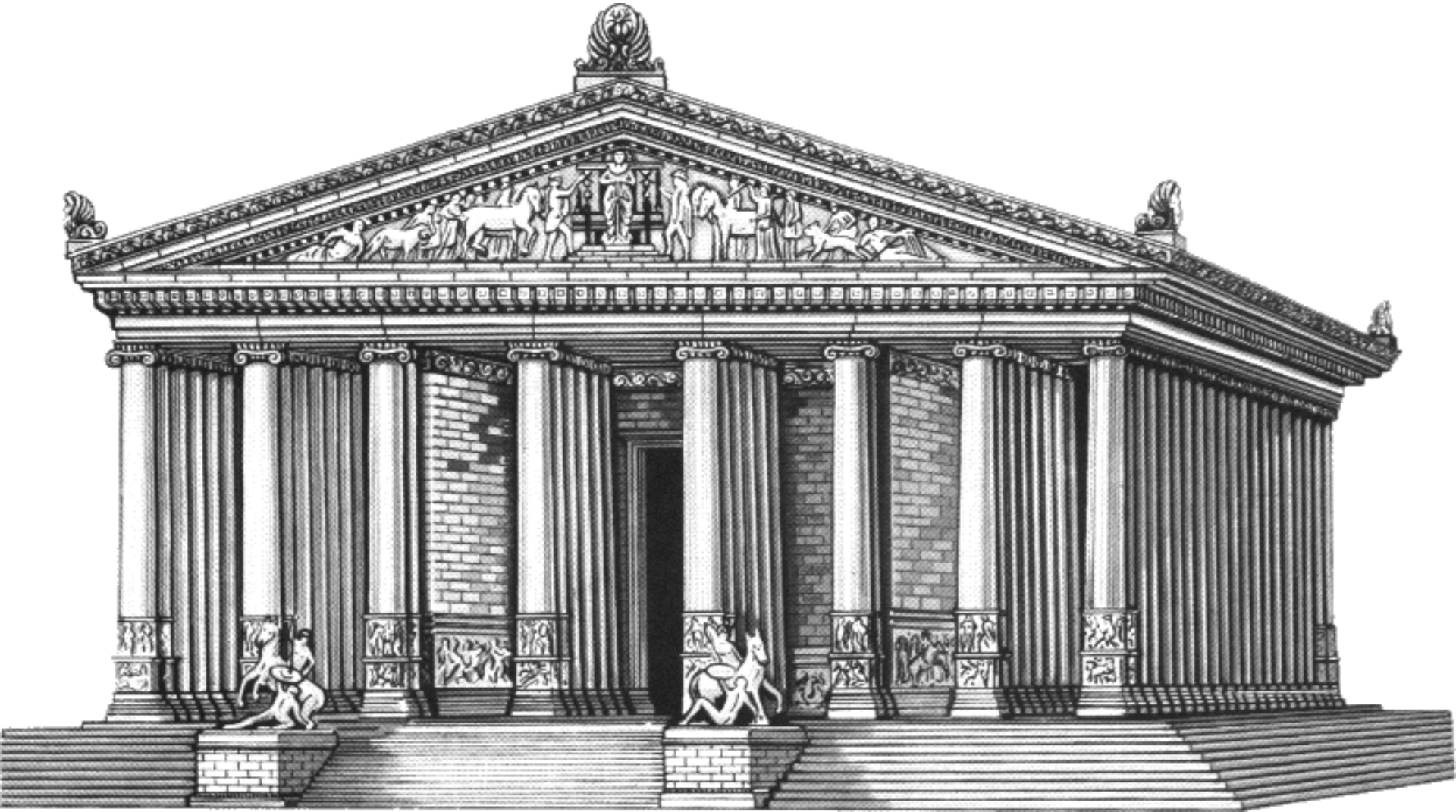

Tapınak Planları

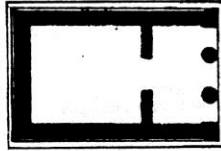

templum in antis
distyli in antis
Themis tapınağı, Rhamnus

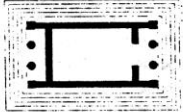

amphidistyl in antis
Diana tapınağı propylaea, Eleusis

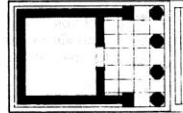

prostylos
yukarı agora tapınağı, Bergama

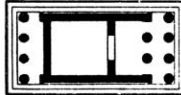

amphiprostylos
İlissos tapınağı, Atina

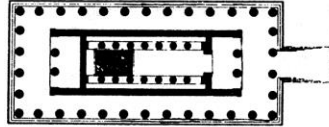

peripteros
Olympia Zeus tapınağı

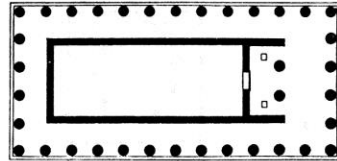

peripteros
Athena tapınağı, Assos



pseudo-peripteros

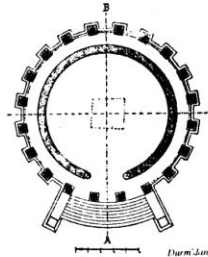

ROMA'DA VESTA TAPINAĞININ PLANI
peripteral

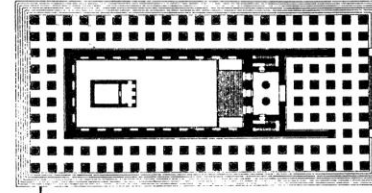

dipteros
Hellenistik Didymaion

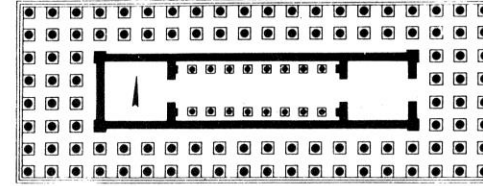

dipteros
Zeus Olympios
tapınağı, Atina

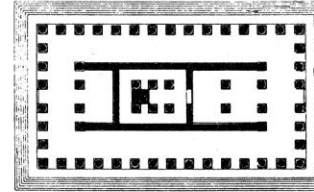

pseudo-dipteros
Magnesia Artemis tapınağı

antik Yunan tapınağı

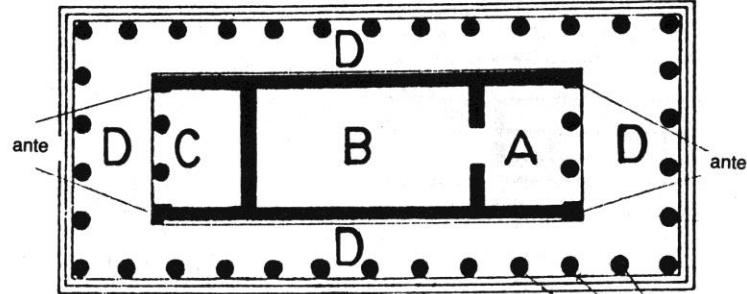

- A- pronaos
- B- naos (cella)
- C- opisthodomos
- D- pteroma

peristasis
(peristylum)

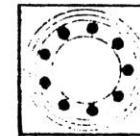

monopteral
Roma'nın Asya



Antentempel

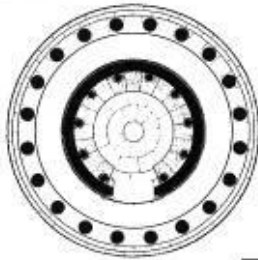

Tholos (Delphi)



Monopteros
Athen Akropolis

0 5 m



Doppelantentempel

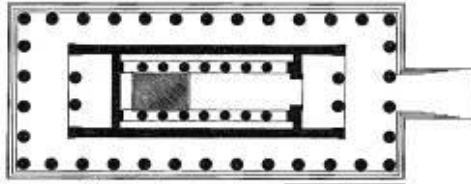

Peripteros (Olympia, Zeustempel)

0 10 20 m

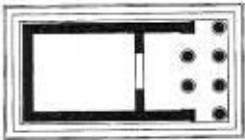

Prostylos

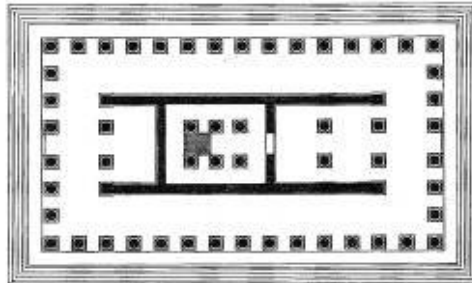

Pseudodipteros (Magnesia, Artemision)



Amphiprostylos (Athen, Illostempel)

0 5 m

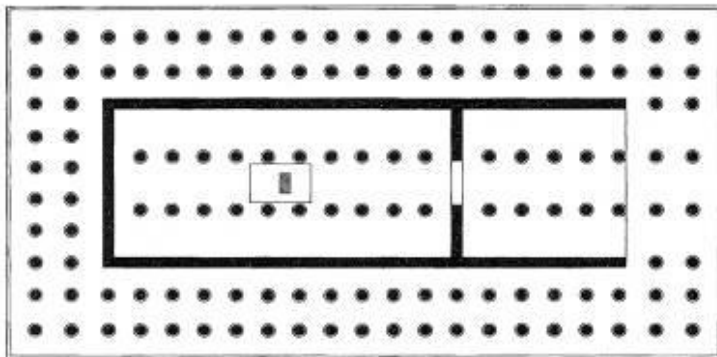

Dipteros (Samos, Rhoikostempel)

0 10 20 m



Abb. 12 Klaros, Apollontempel



Abb. 13 Xanthos, Letoon

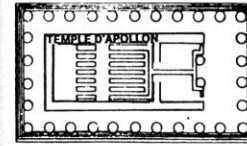

Abb. 14 Pergamon, Trajanum

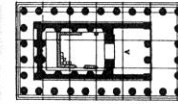

Abb. 15 Side, Apollontempel

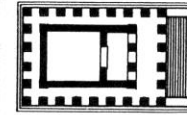

Abb. 16 Sagalassos, Antoninus-Pius-Tempel

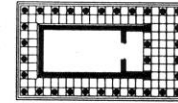

Abb. 17 Termessos, Zeus-Solymius-Tempel

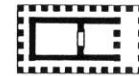

Abb. 18 Teos, Dionysostempel

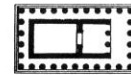

Abb. 19 Euromos, Zeustempel

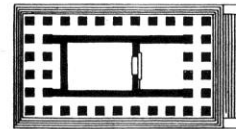

Abb. 22 Magnesia, Artemistempel

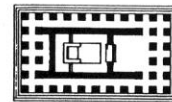

Abb. 20 Lagina, Hekateion

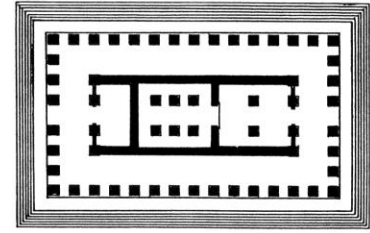

Abb. 23 Ankyra, Augustus- und Romatempel

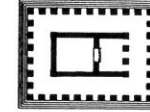

Abb. 21 Pergamon, Dionysostempel

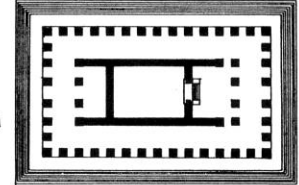

Abb. 24 Aphrodisias, Aphroditetempel

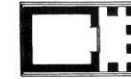

Abb. 25 Sardeis, frühkaiserzeitlicher Tempel

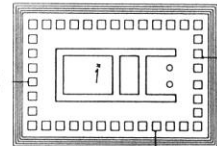

Abb. 26 Ephesos, Domitianstempel

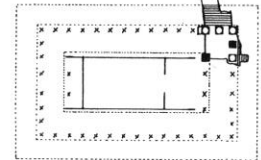

Abb. 27 Aizanoi, Zeustempel

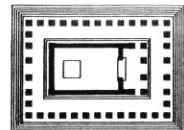

1. IN ANTIS

2. AMPHI DISTYLOS IN ANTIS

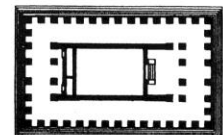
3. PROSTYLOS

4. AMPHIPROSTYLOS

5. PERIPTEROS

6. DIPTEROS

7. PSEUDODIPTEROS



4

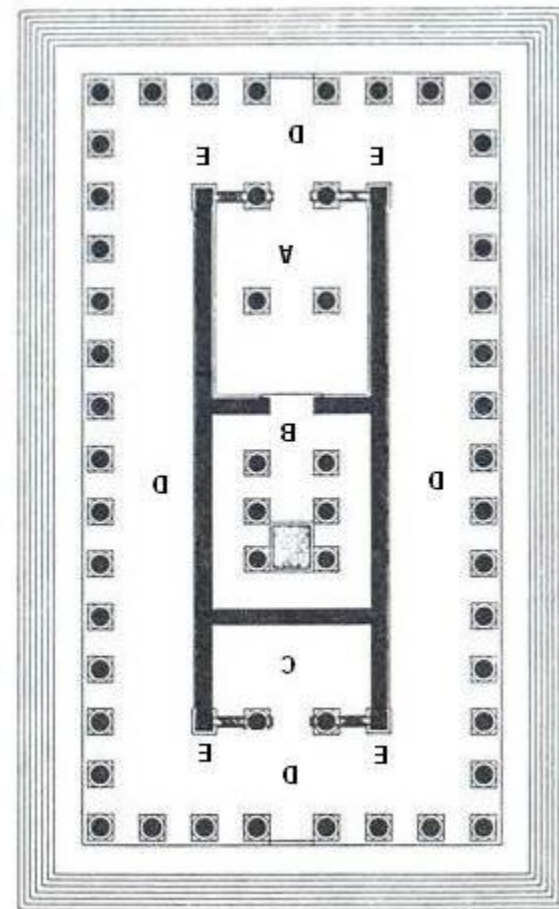
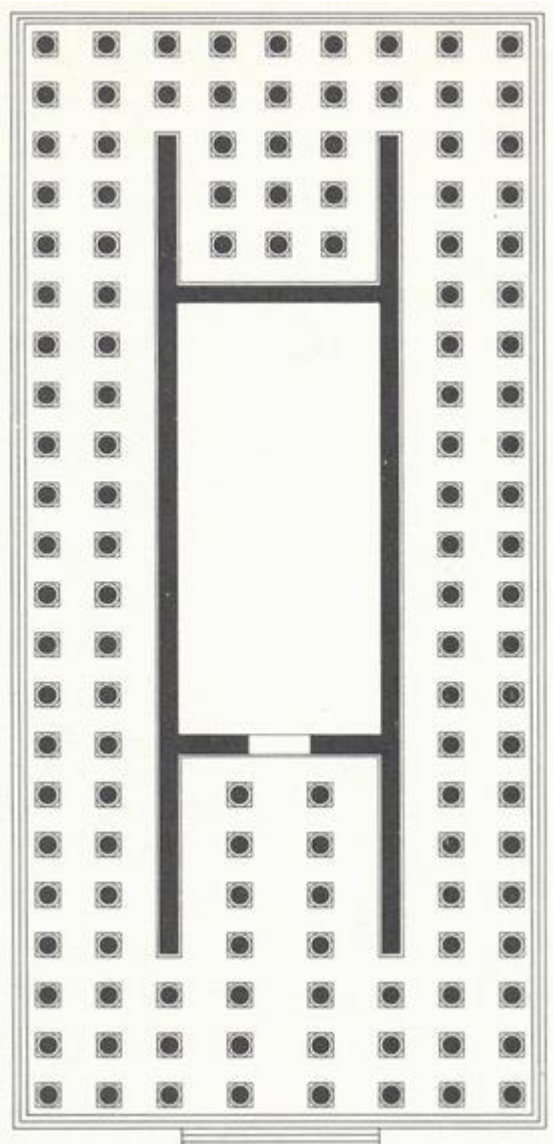
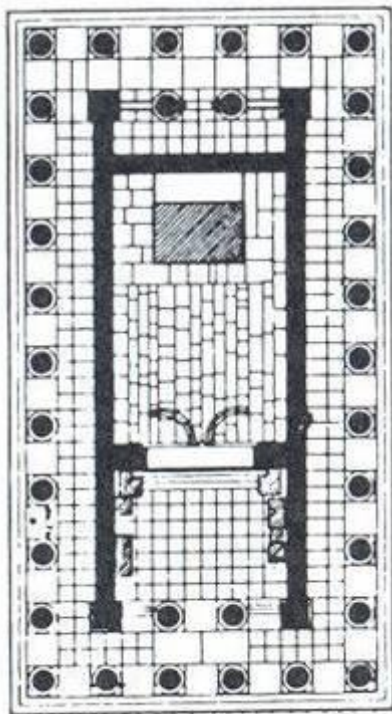

antik Yunan tapınağı

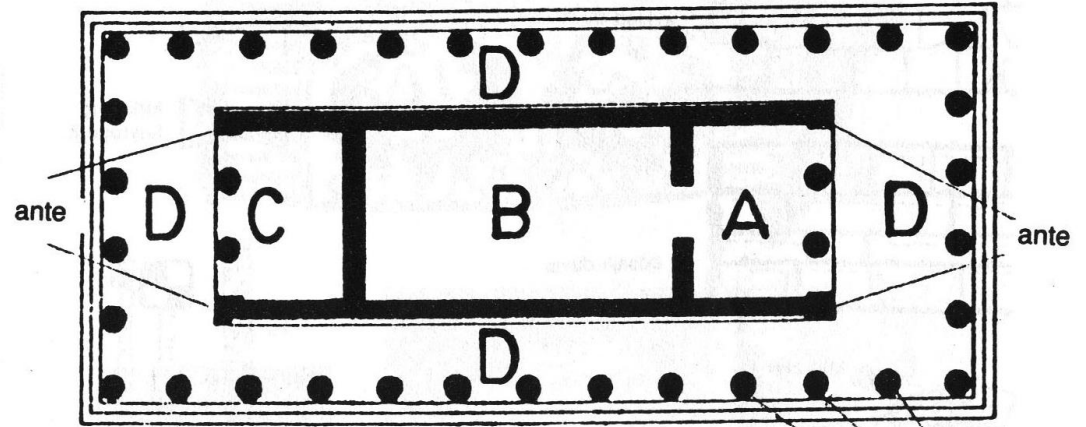

- A- pronaos
- B- naos (cella)
- C- opisthodomos
- D- pteroma

peristasis
(peristylum)

