

Ölçme ve Kontrol Aletleri

KUMPAS

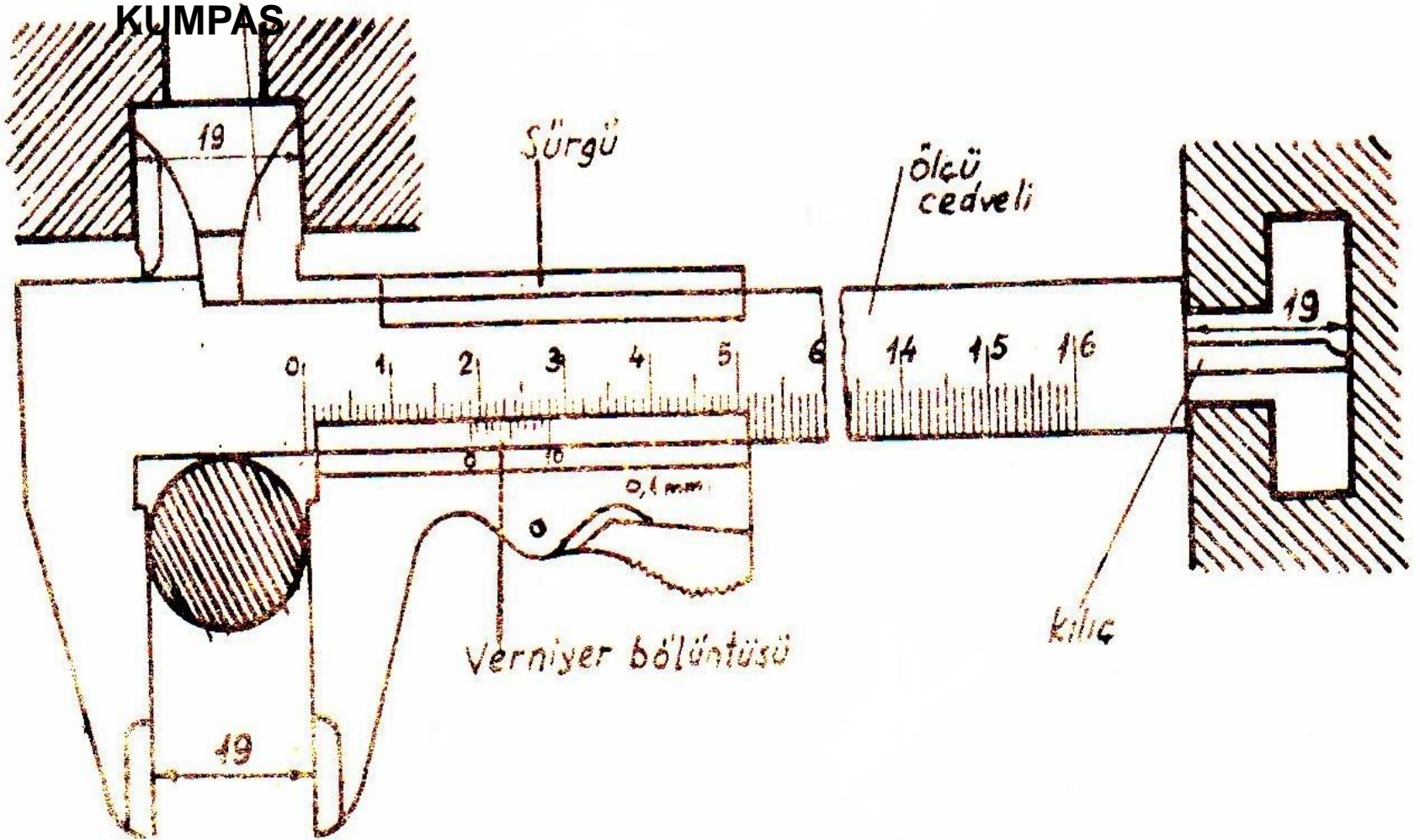

Farklı Kumpas ile İç Çap Ölçme

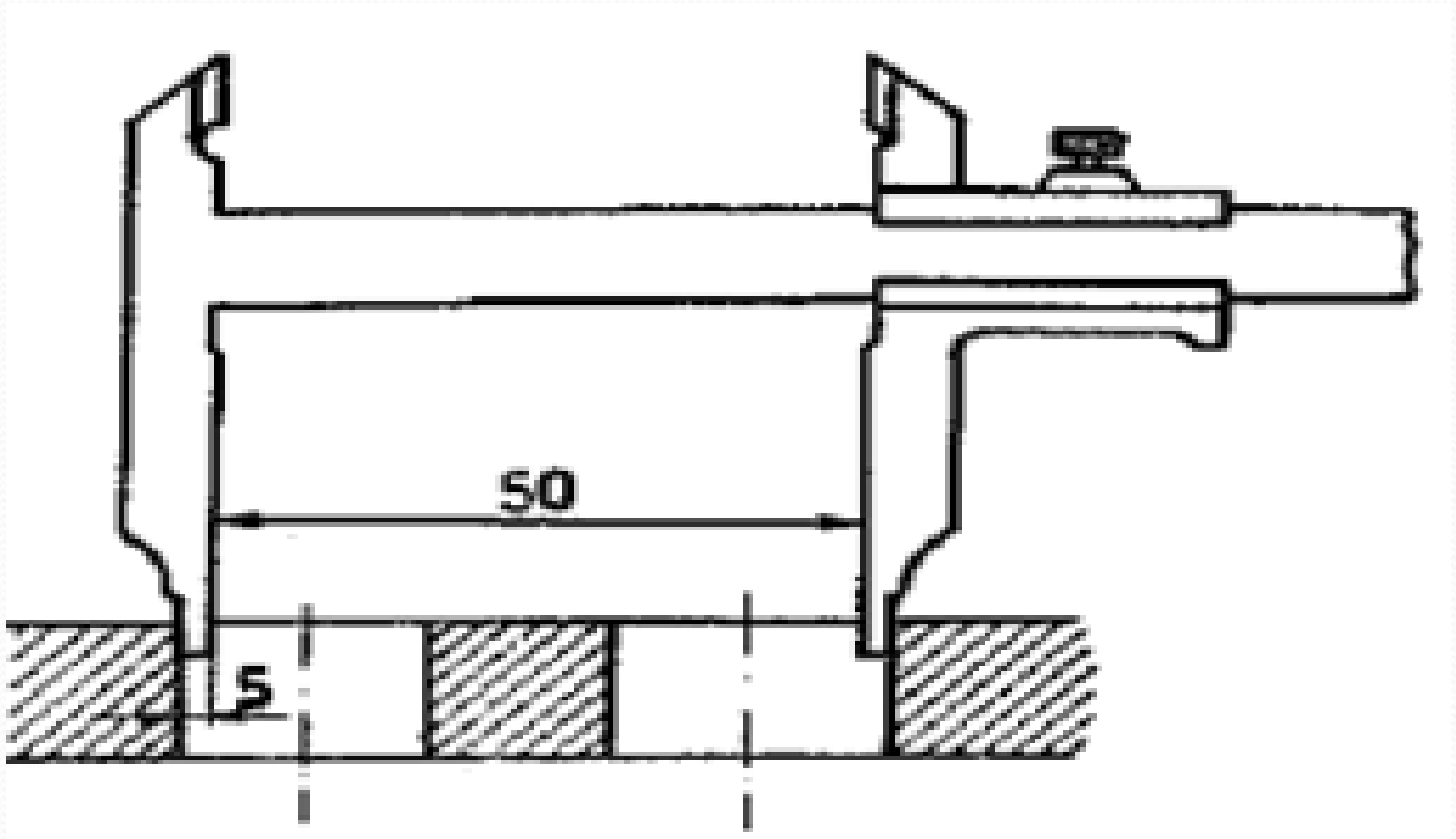

Kumpasta Milimetrik Bölüntü

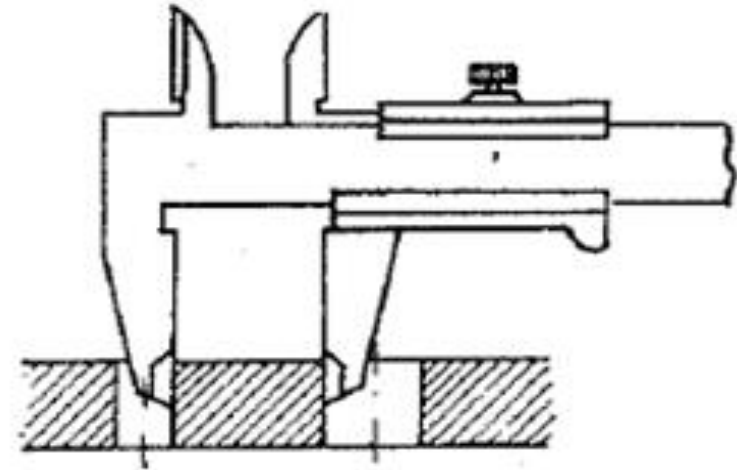
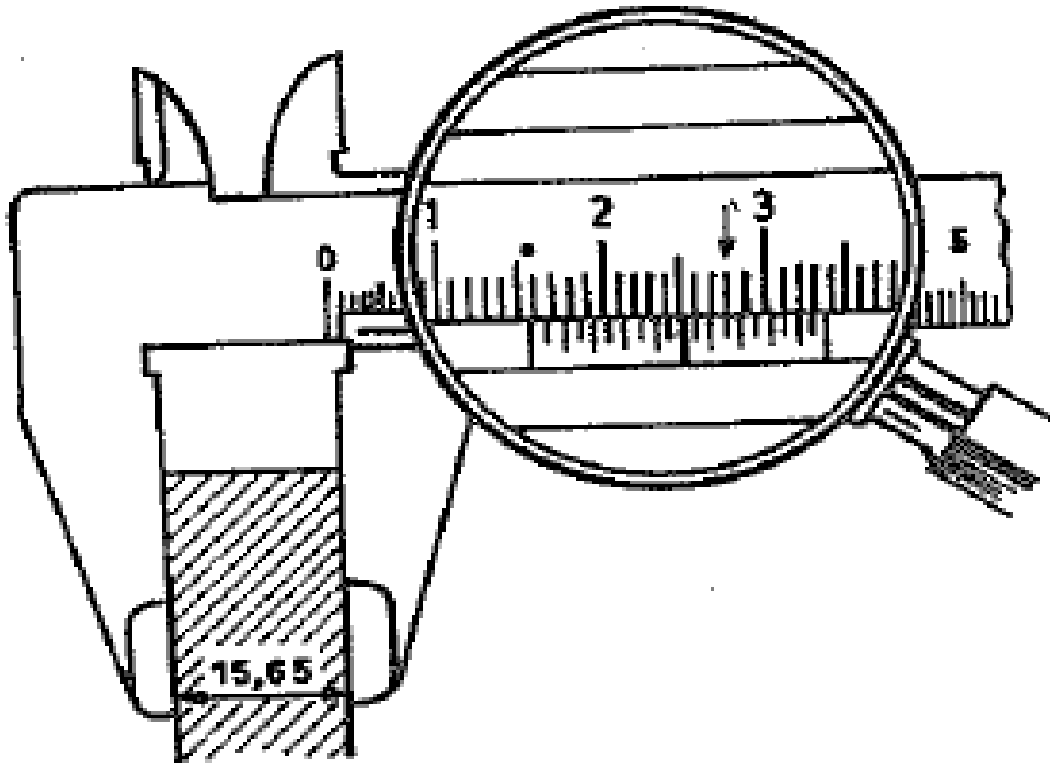

1/10 VERNİYER BÖLÜNTÜSÜ

Ölçü cedveli

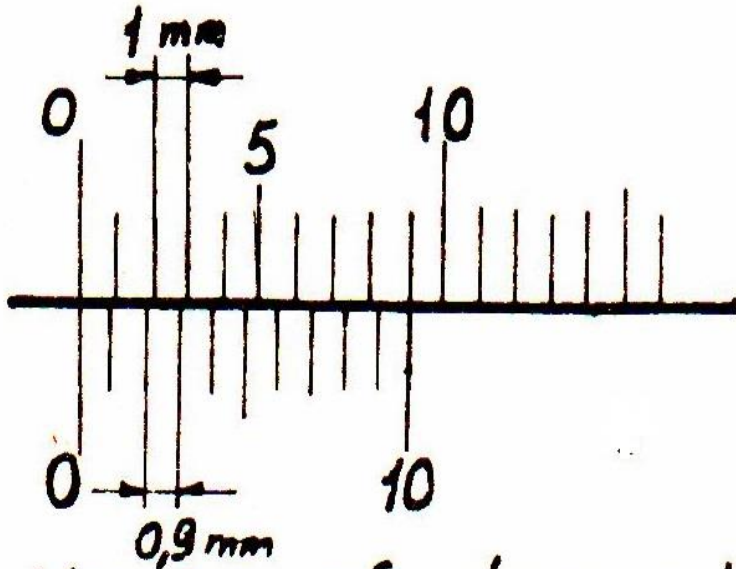

Verniyer sıfır durumunda

Ölçü cedveli

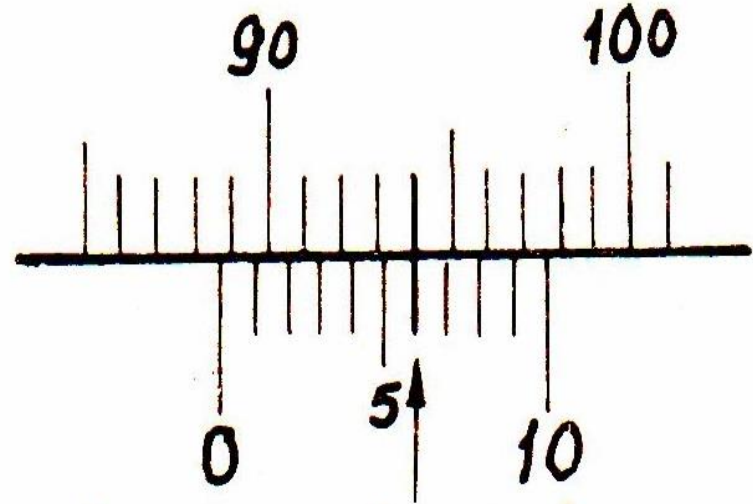

Verniyer ölçme durumunda
ölçü 88,6 dir.

1/20 VERNİYER BÖLÜNTÜSÜ

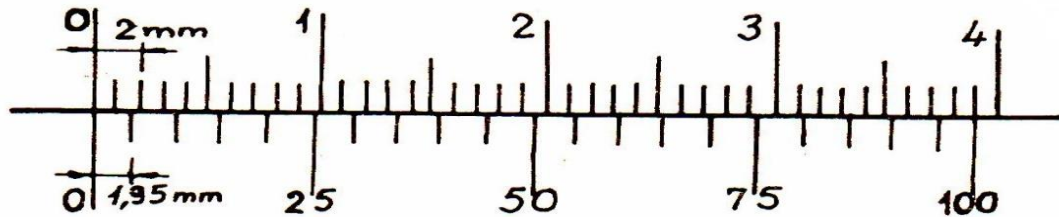

$$\frac{39}{20} = 1,95 \text{ mm.} \quad 2 - 1,95 = 0,05 \text{ mm.}$$

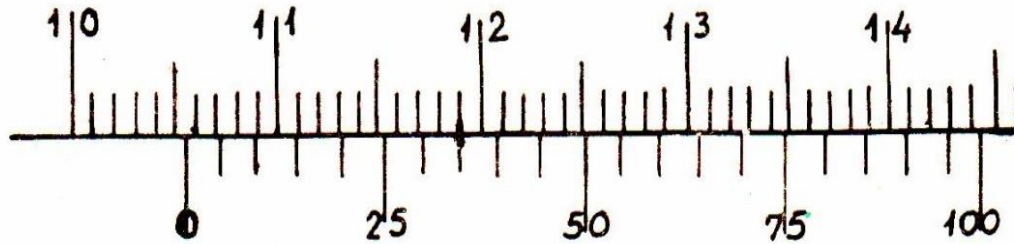

Okunan ölçü 105,35

1/50 VERNİYER BÖLÜNTÜSÜ

Ölçü cedveli

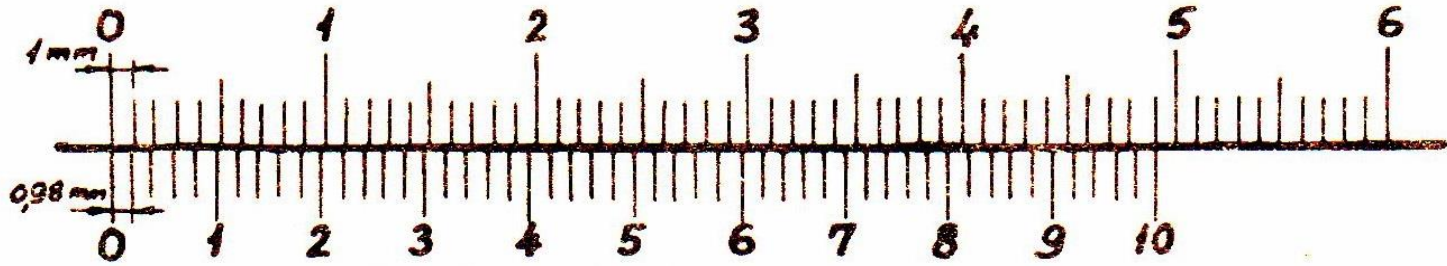

1/50 Verniyerde okuma tamlığı 0,02 mm.

Şekil : 25 1/50 mm. verniyer bölüntüsü

Ölçü cedveli

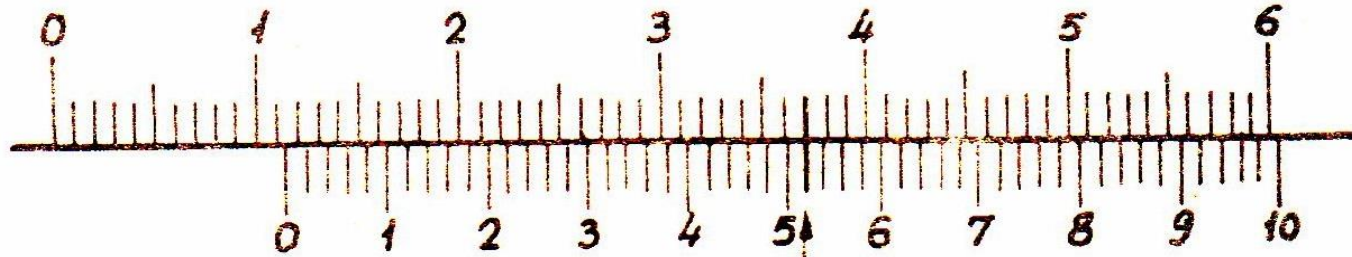

1/50 Verniyer okuma durumunda
okunan ölçü 11,52 mm.

Ölçme

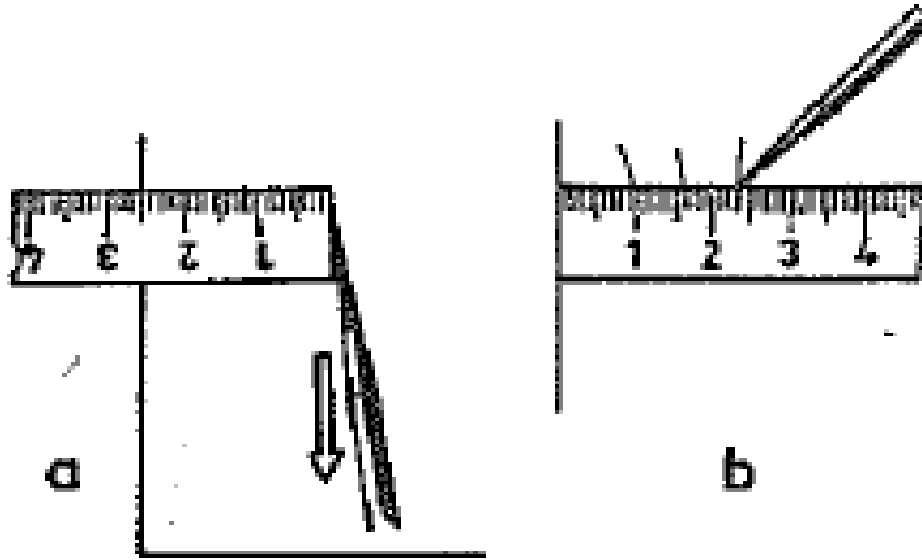

Parça üzerine bölüntülü cetvel ile ölçü işaretlerken şekil: a daki gibi hareket edilmelidir. Şekil: b deki gibi ölçü işaretlemek yanlıştır.