

KİL MİNERALOGİSİ

1. Nedir? Tanımı

a. $< 2 \mu\text{m}$

b. bileşimi

- - silikatlar
- kaolin, smektit grubu vs. Kaolinit, montmorillonit vs
- - oksitler
- SiO_2 , Fe_2O_3 , Al_2O_3

1. Niçin Önemlidir?

a. kimyasal özellikleri

- - birçok reaksiyon için geniş yüzey alanı
- - elektiriksel yük

1. positif yük (çok ayrışmış topraklarda anyon adsorbsiyonu)

2. negatif yük (en genel olan, Ca^{2+} , Mg^{2+} , K^+ , NH_4^+ , Na^+)

3. deęişebilir yük (pH'ya baęlı)

b. fiziksel özellikleri

- - suyu sıkıca tutar
- - şişer – büzülür, porlar suyla dolunca kapanır, kök gelişimini etkiler

1. Nerden Gelirler?

a. Kalıtsal

b. Toprak içinde oluşur

- toprakta hafif değişimler, mika → vermikulite

- silikat artıklarının yeniden birleşimi

- iyonlardan oluşum

laboratuarda kaolinit, smektit

arazide yeni mineraller (ana materyalle ilişkili olmayan)

1. Sonunda Ne olur?
 - a. ayrışmaya dayanıklı olanlar toprakta kalır
 - b. diğer kil minerallerine dönüşür
 - c. erozyona uğrar, yıkanır
 - d. çözünür ayrışma ürünleri uzaklaşır
 - e. en sonunda Fe, Al oksitler şeklinde kalır
Si yıkanır

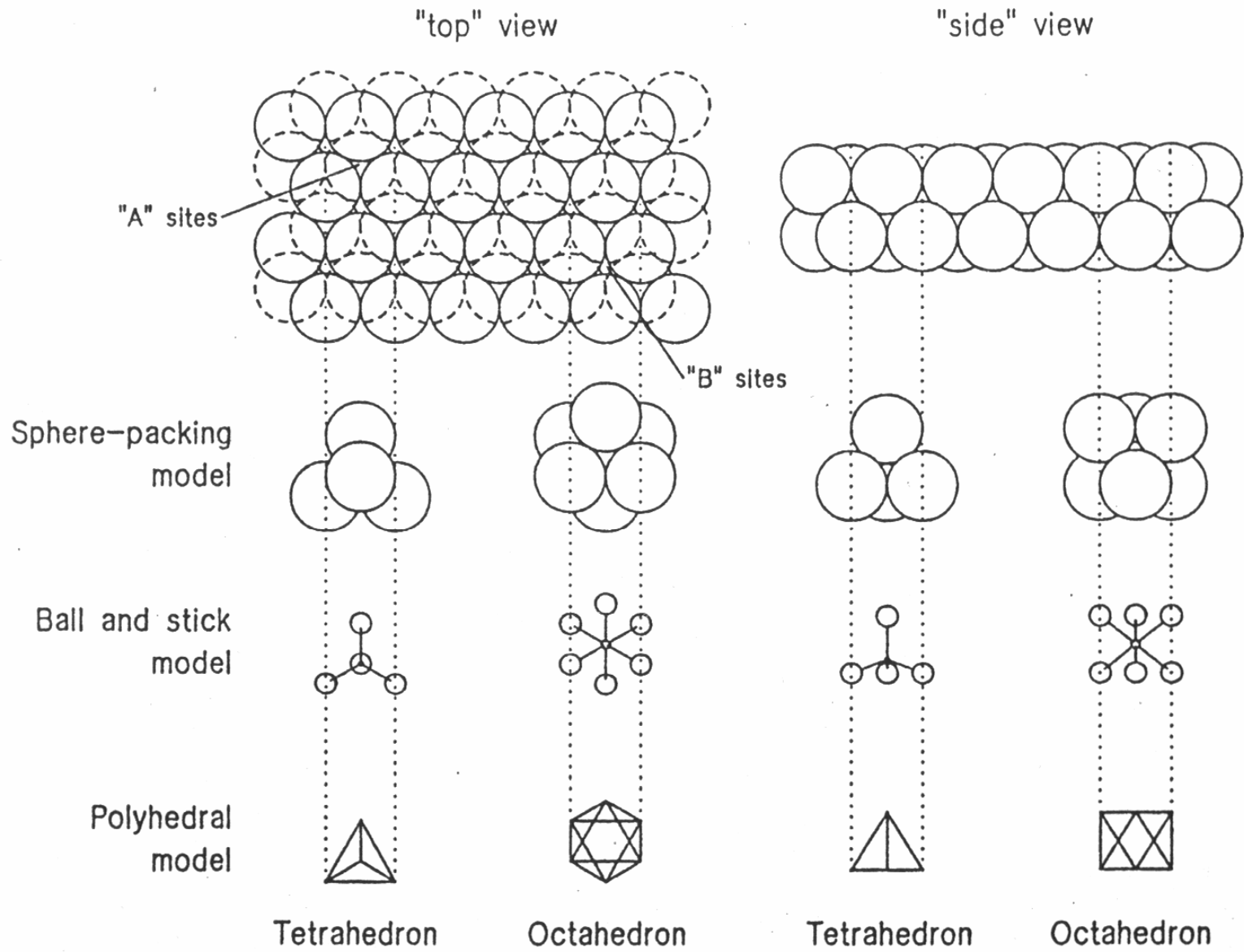

Fig. 1-3. Octahedra and tetrahedra as a consequence of two planes of close-packed spheres and three ways of representing octahedra and tetrahedra.

The Tetrahedral Sheet

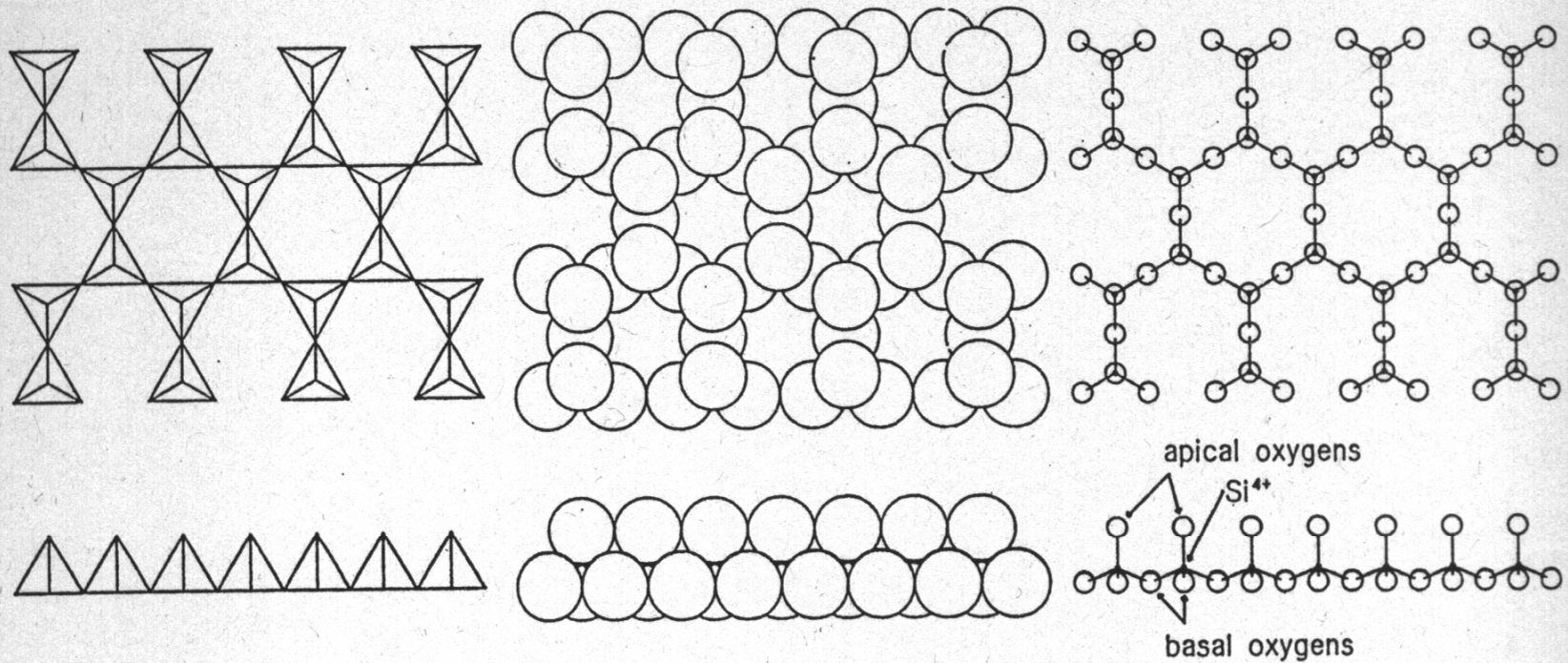
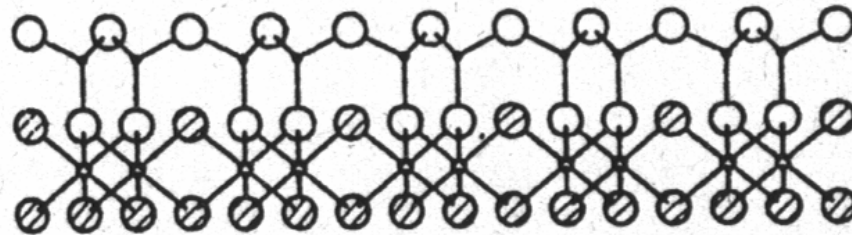

Fig. 1-5. The tetrahedral sheet.

PLANES OF IONS

- basal O's →
- tetrahedral cations →
- OH's & apical O's →
- octahedral cations →
- OH's →



SHEETS, LAYERS

- tetrahedral sheet
 - octahedral sheet
- } 1:1 layer

- basal O's →
- tetrahedral cations →
- OH's & apical O's →
- octahedral cations →
- OH's & apical O's →
- tetrahedral cations →
- basal O's →

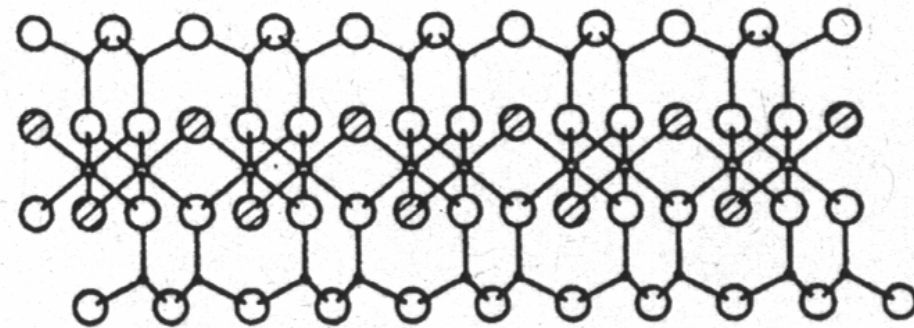

- tetrahedral sheet
 - octahedral sheet
 - tetrahedral sheet
- } 2:1 layer

The Octahedral Sheet (trioctahedral)

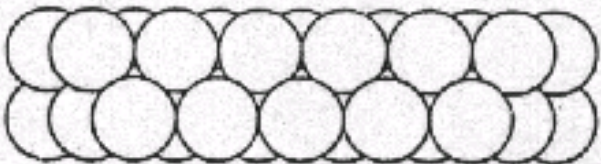
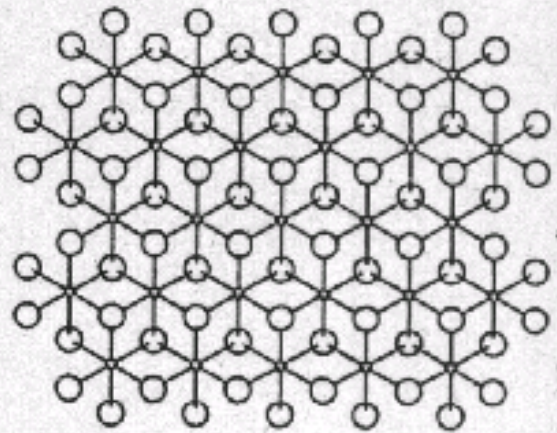
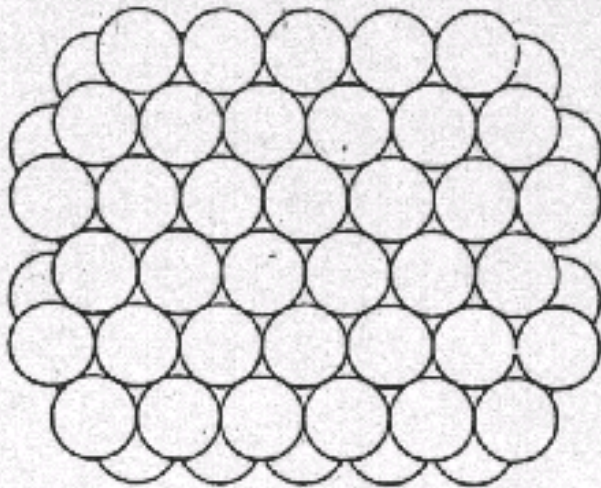
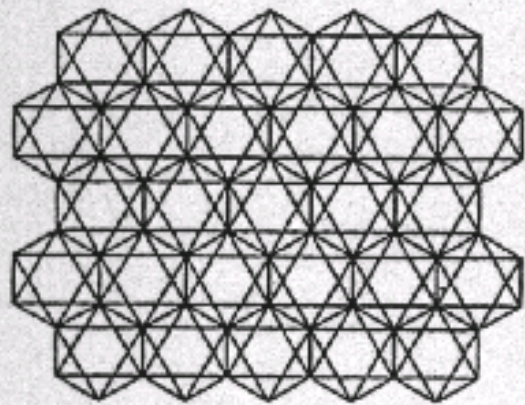

The Octahedral Sheet (dioctahedral)

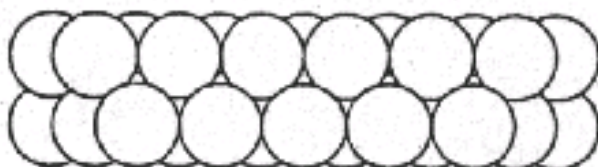
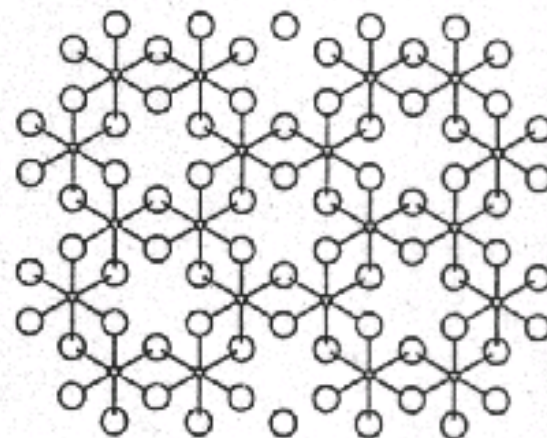
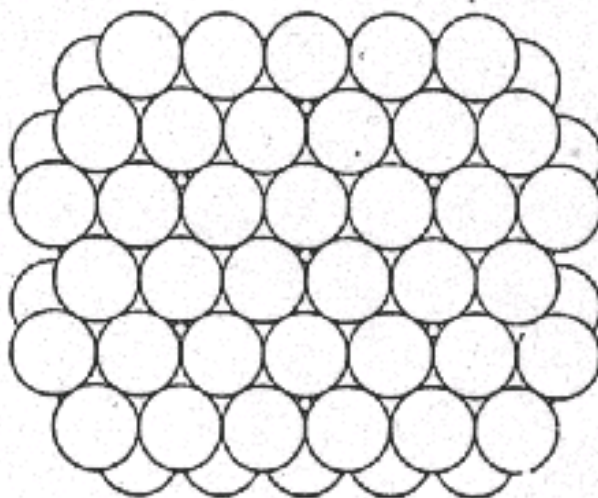
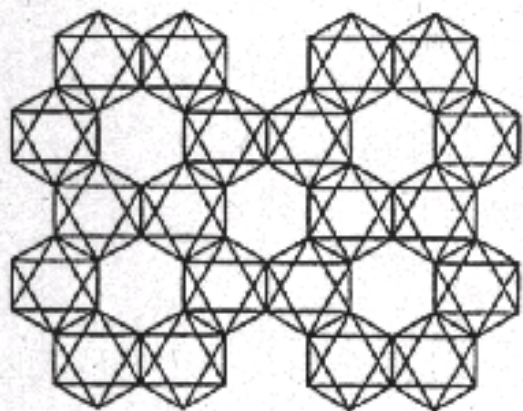

Tabakalı Silikat Killerinin Yapısı (basit yapı blokları)

1. Tetrahedron - SiO_4

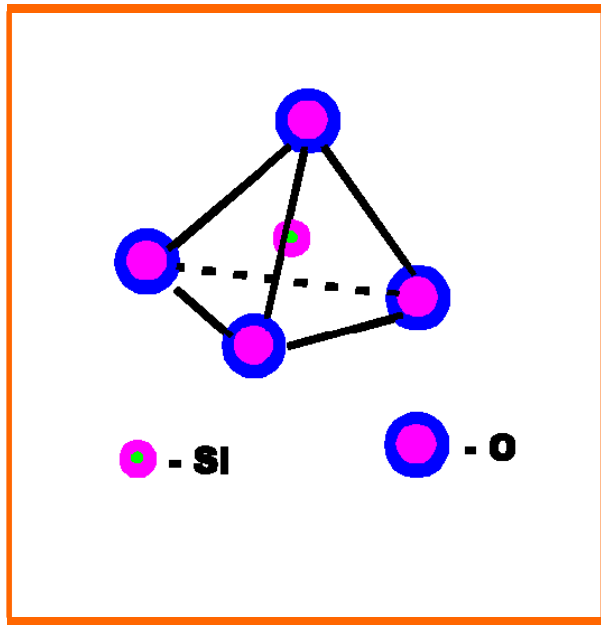

2. Octahedron - $\text{Al}(\text{OH})_6$

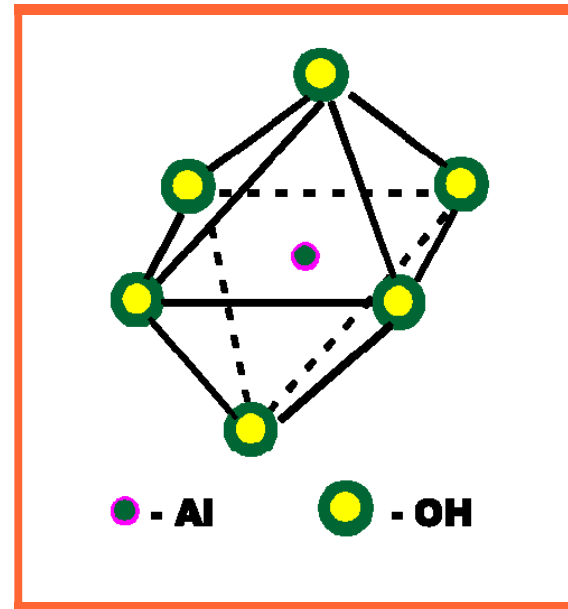

O ve OH gruplarının paylaşımı = *levhalar* ve birim *tabakalar*

(a) tetrahedral tabaka

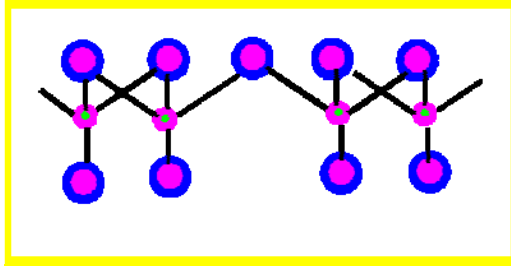

(b) octahedral tabaka

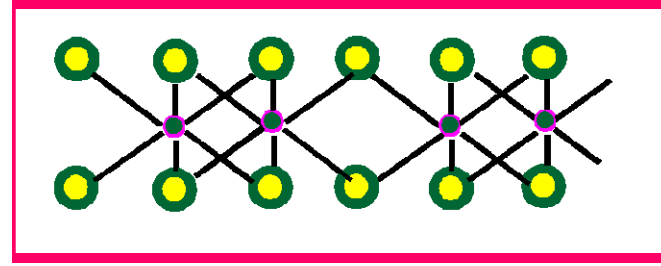

Tetrahedral ve octahedral tabakalar aşağıda gösterildiği gibi çizilirler



Tetrahedral sheet

Octahedral sheet

Birim tabaka ve iç alan

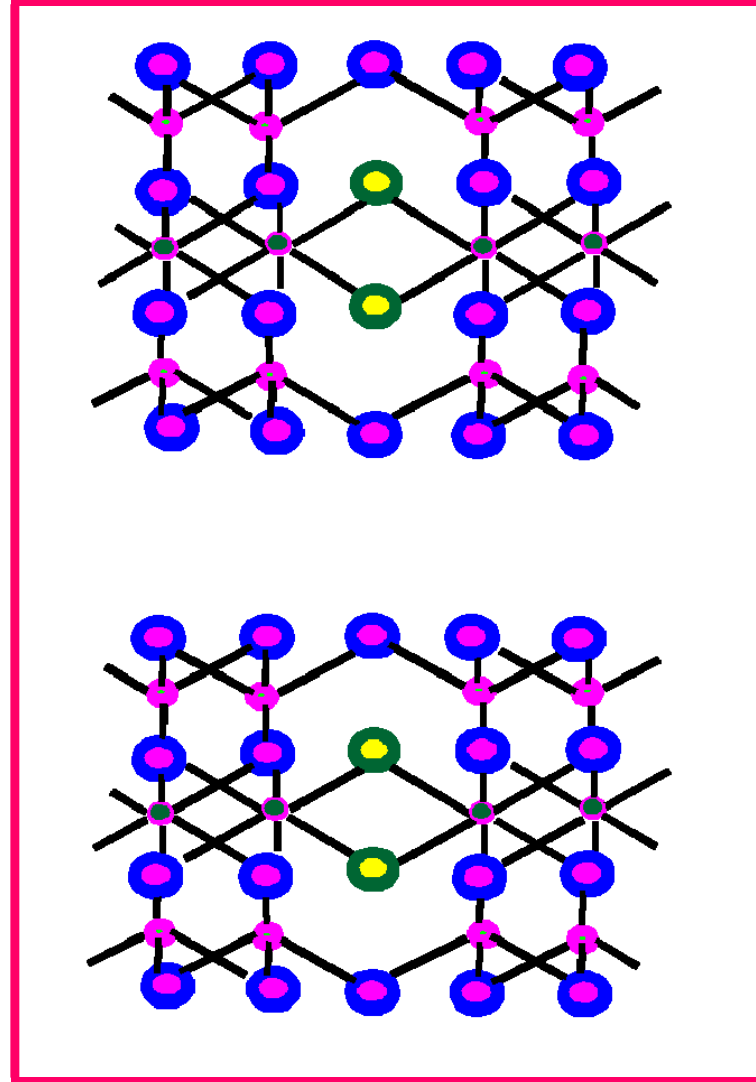

Si-Tetrahedron

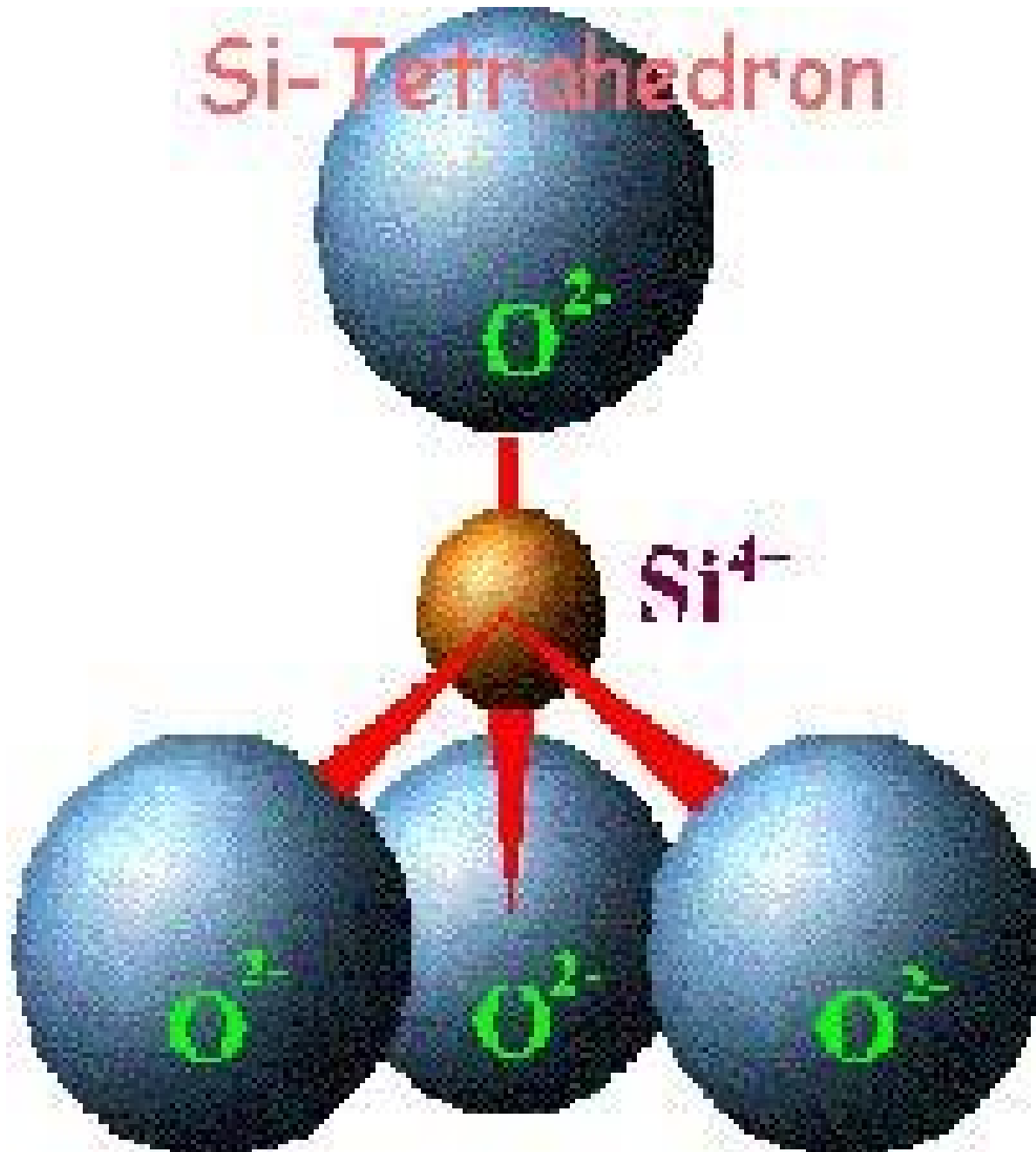

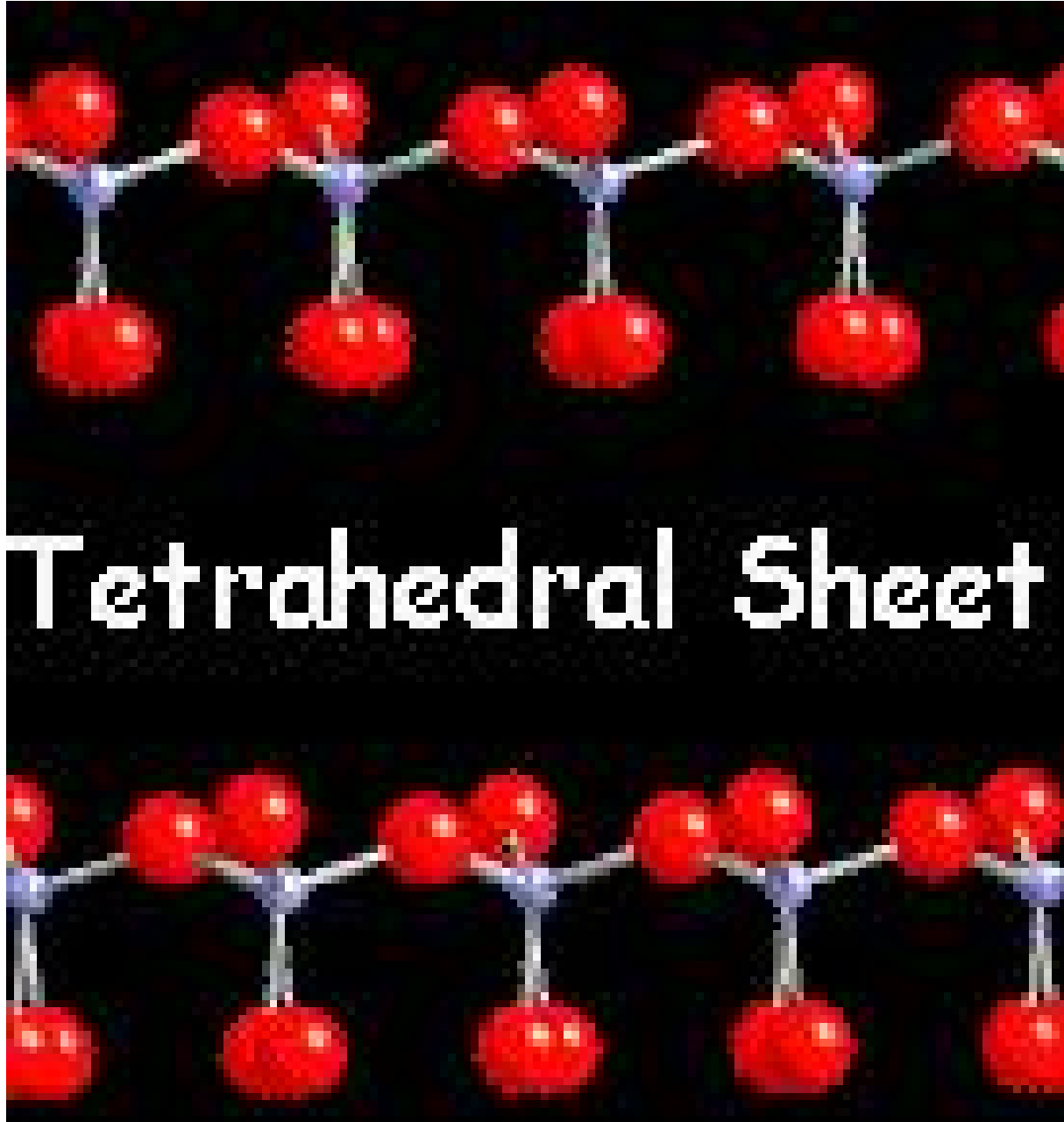

Tetrahedral Sheet

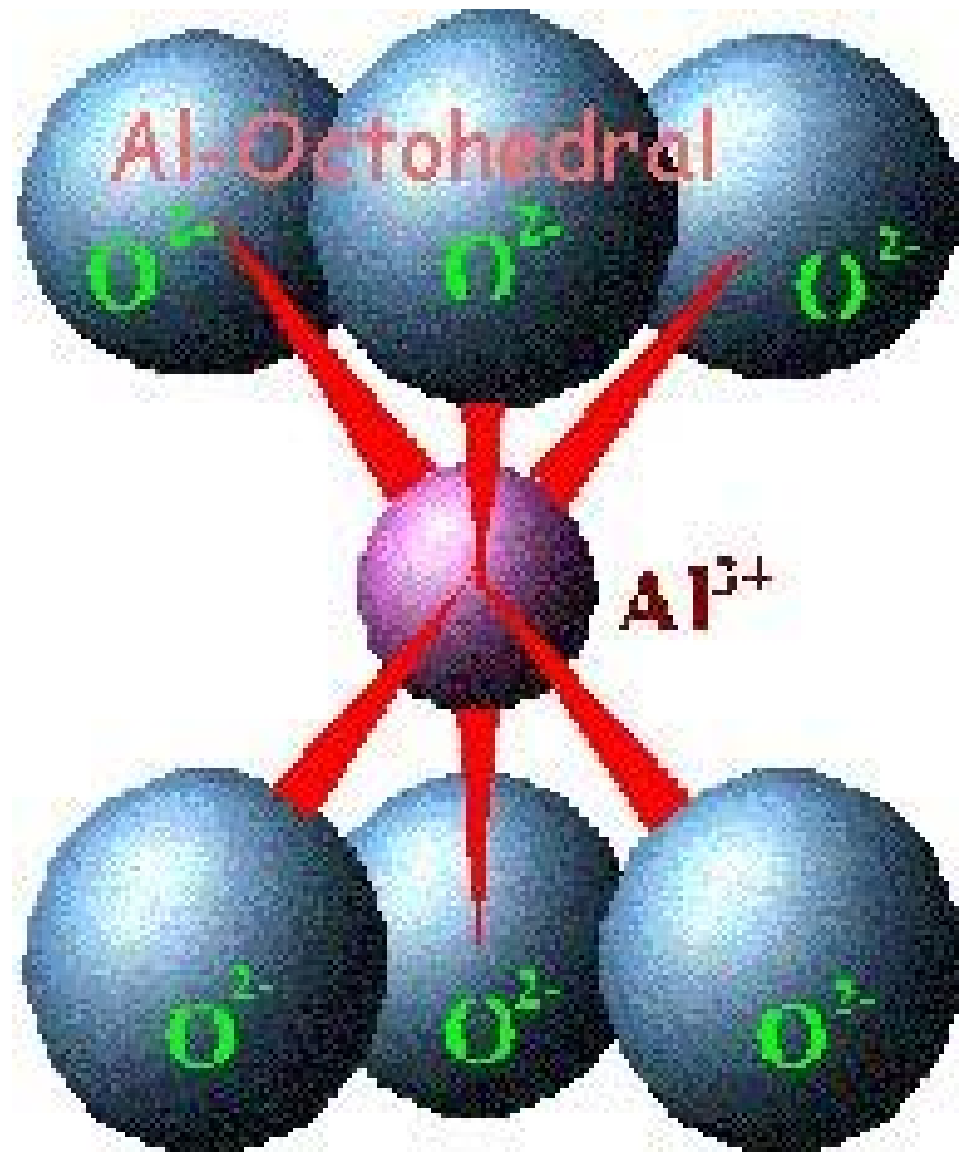

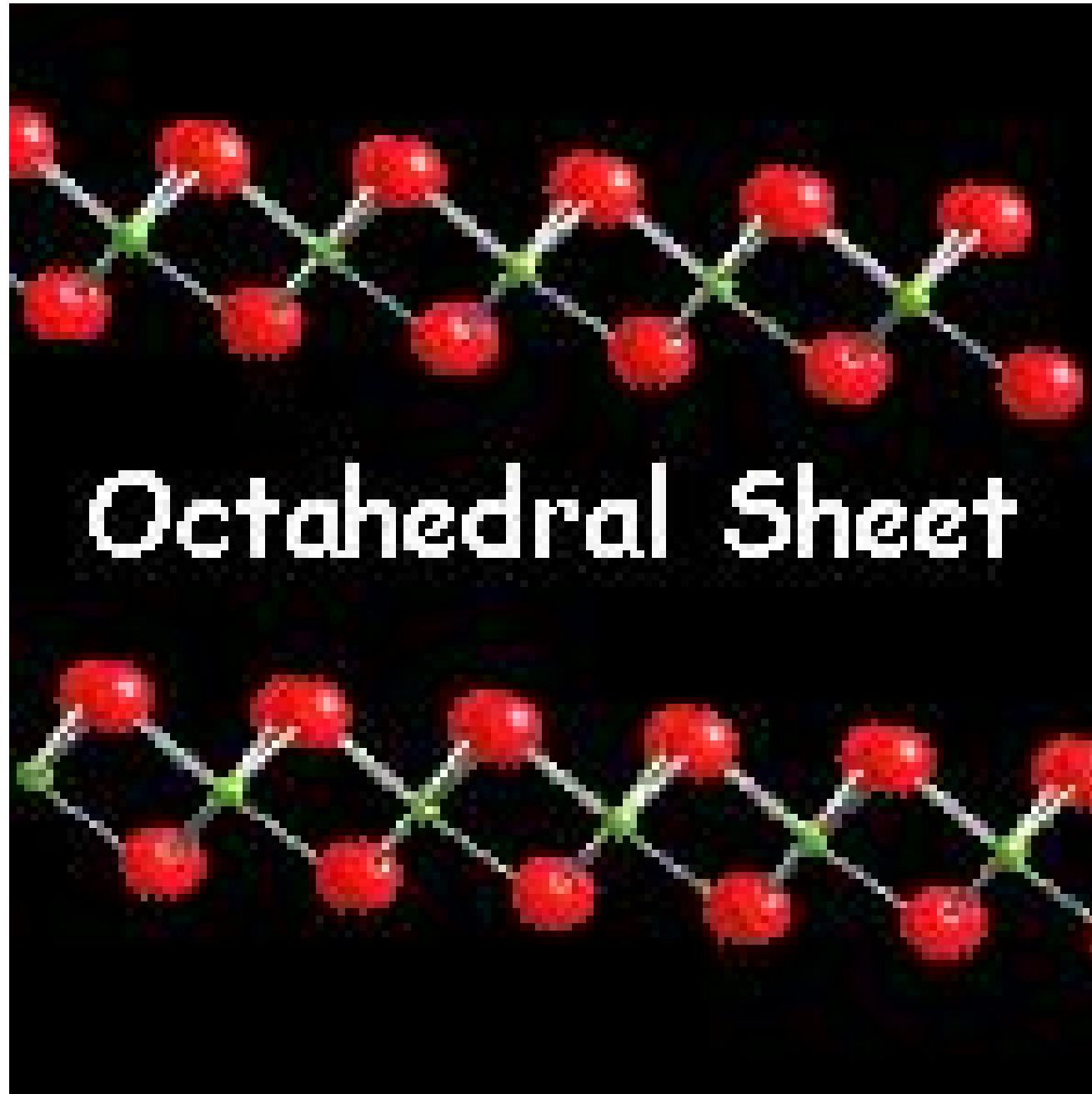

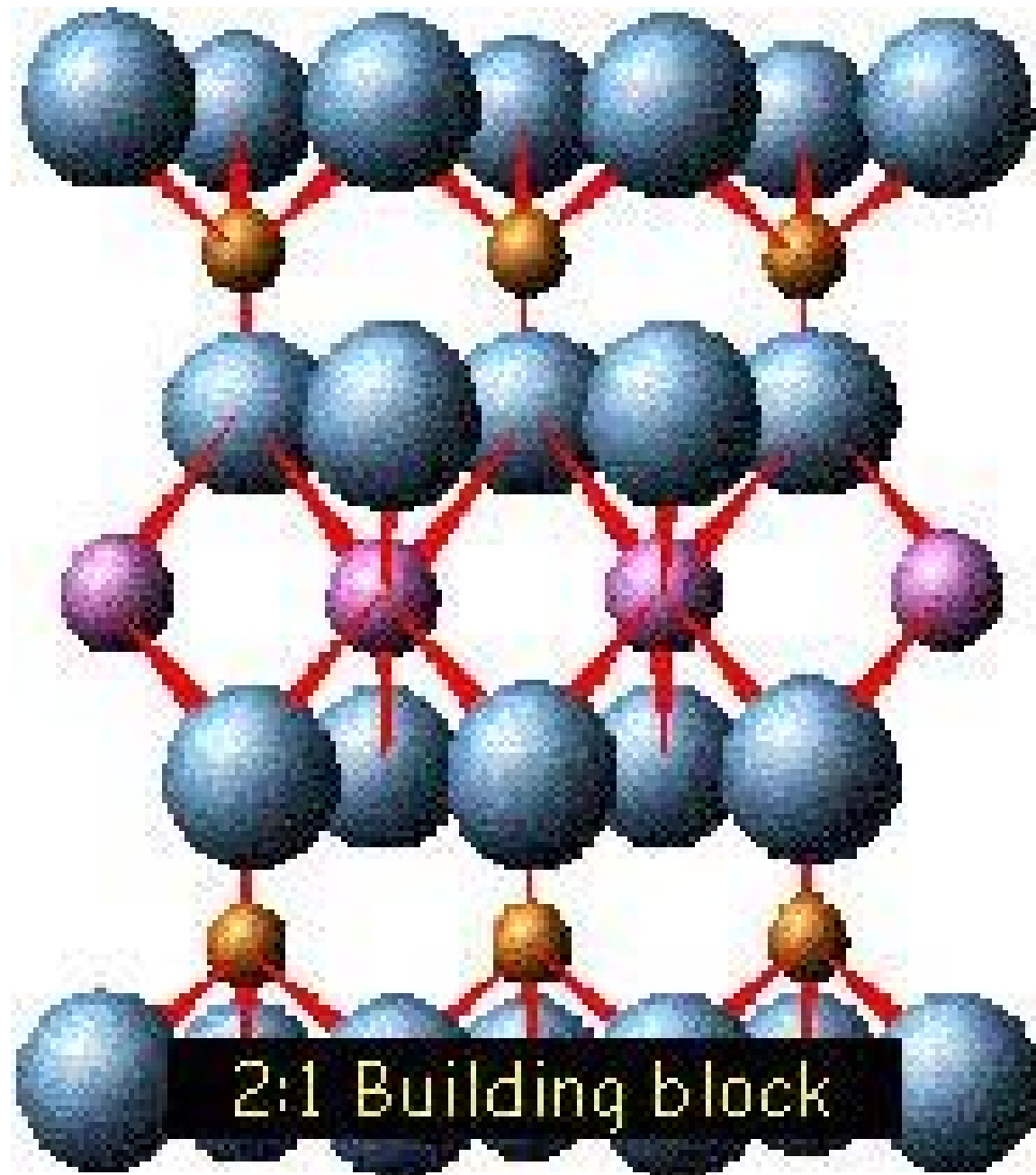



İzomorfik yerdeğişim = kristal oluşumu sırasında atomların yerdeğişimi

Zn⁺² for Al⁺³
or Al⁺³ for Si⁺⁴
or Cu⁺² for Mg⁺²

Devamlı yüklere (permanents charge) neden olur

Substitution	Charge Deficit
Al ⁺³ for Si ⁺⁴	-1
Mg ⁺² for Al ⁺³	-1

A. 1:1 Type Minerals

1. Mostly, *kaolinite*

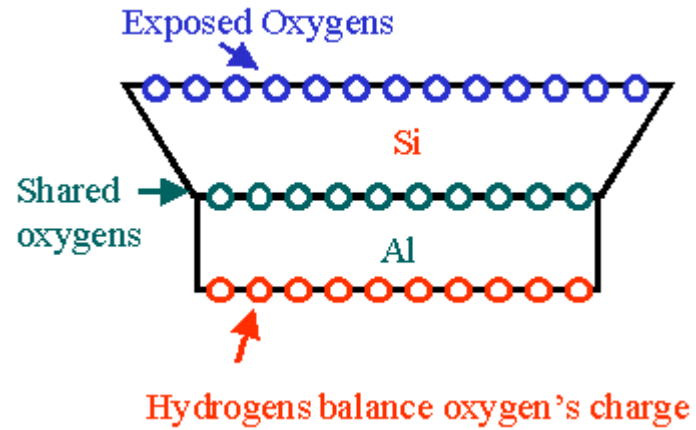
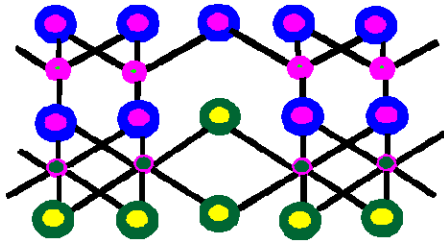

2. Unit layers H-bonded together

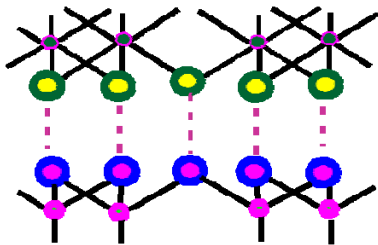

7Å°

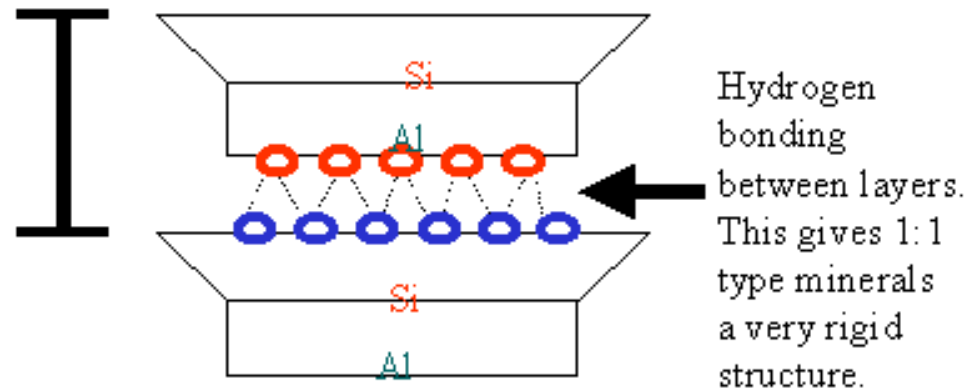

- ➔ genişlemeyen sabit tabaka "fixed lattice type"
- ✓ tabakalar içersinde negatif yük yok (no interlayer activity)
- ✓ Şişme – büzülme yok (no shrink-swell)
- ✓ Sadece dış yüzeylerde katyon değişimi (only external surface)
 - ✓ İyi cirstallenmiş (Well crystallized)
- (a) Çok az izomorfik değişim (little isomorphous substitution)
 - ✓ Düşük katyon adsorsiyonu (low cation adsorption)
- (b) Büyük tane büyüklüğü (larger particle size (0.1 - 5 μ m))
 - hexagonal şekilli (shaped)

B. 2:1 Tipi Kil Mineralleri

1. Genişleyen tabakalı

(a) Smectite grubu (genelde, *montmorillonite*)

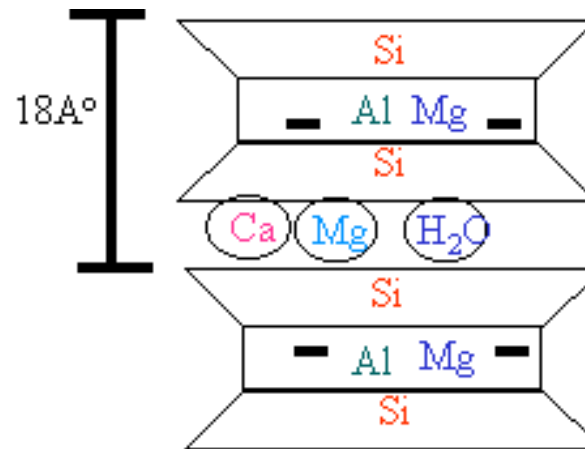
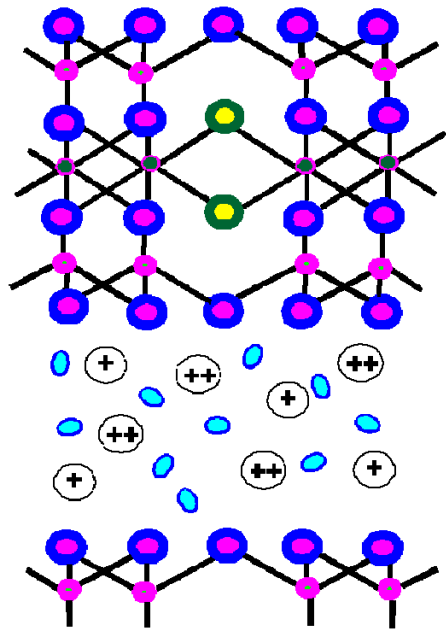

Some substitution of Mg for Al in the octahedral layer leads to permanent negative charge. Ca or Mg can move into the interlayer spaces. Water can also move in and out

(b) Serbestçe genişleyen

* tabakalar arasında su = yüksek şişme-büzülme

* tabakalar arasında adsorbe katyonlar

- iç ve dış yüzeylerde izomorfik değişim

* geniş iç yüzey

(c) Zayıf kristallenmiş

* boyutları küçük

* izomorfik değişim = yüksek katyon adsorbsiyonu

(d) Vermiculite

* smectites benzer, tetrahedral tabakadaki, yerine Si^{+4} , Al^{+3} yok

* tabakalar içi iyonlar genelde ($\text{Mg}^{+2} + \text{H}_2\text{O}$) ile yapılandırılmıştır

= sınırlı genişleme

* yüksek katyon adsorbsiyonu

2. Genişlemeyen tabakalı

(a) İnce taneli mikalar veya illit

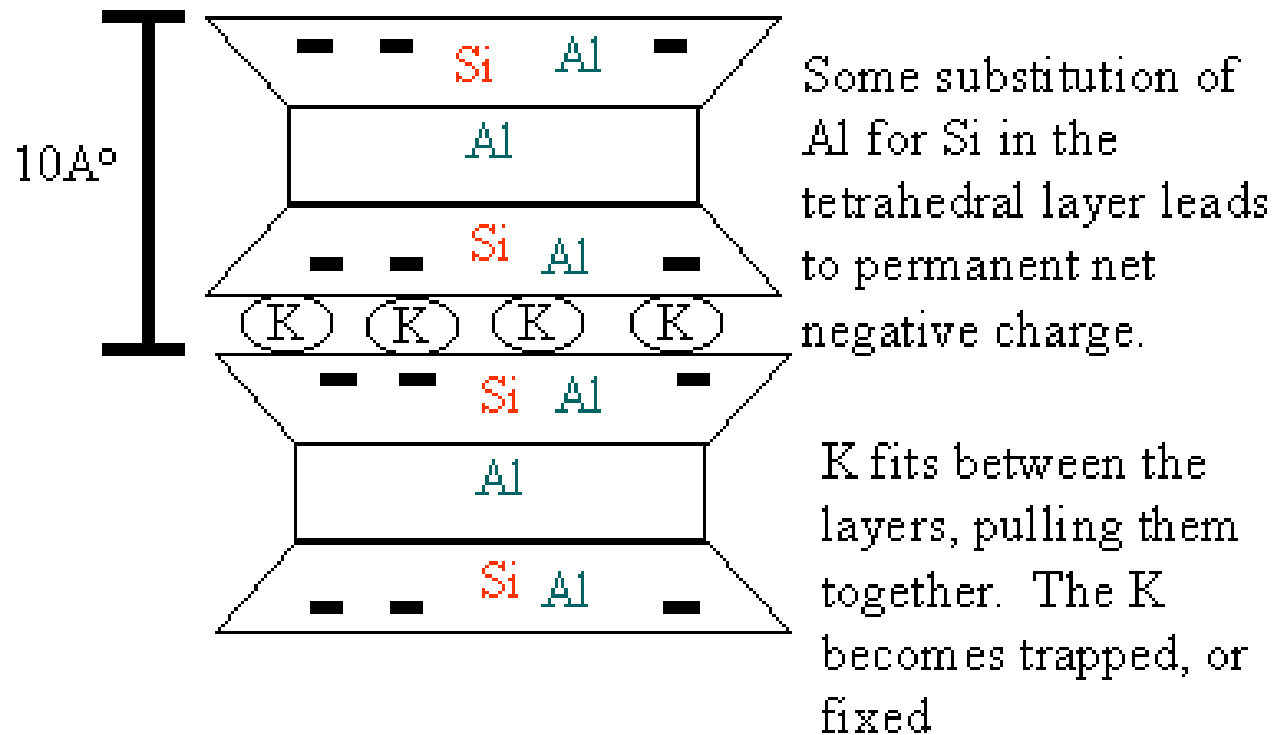

◆ Al^{+3} ve K^+ yerdeğişimi, Si^{+4} (tetrahedral sheet) için

◆ Kenarlarda ayrışma = K^+ salınımı

- çok sınırlı genişleme

- orta katyon adsorbsiyonu

- sınırlı iç yüzey

- kaolinite ve vermiculite arasındaki özellikler

(b) Kloritler (Chlorites)

◆ illite ki K^+ , gibi octahedral tabakaya Mg- yerleşir

◆ illite benzer özellikler

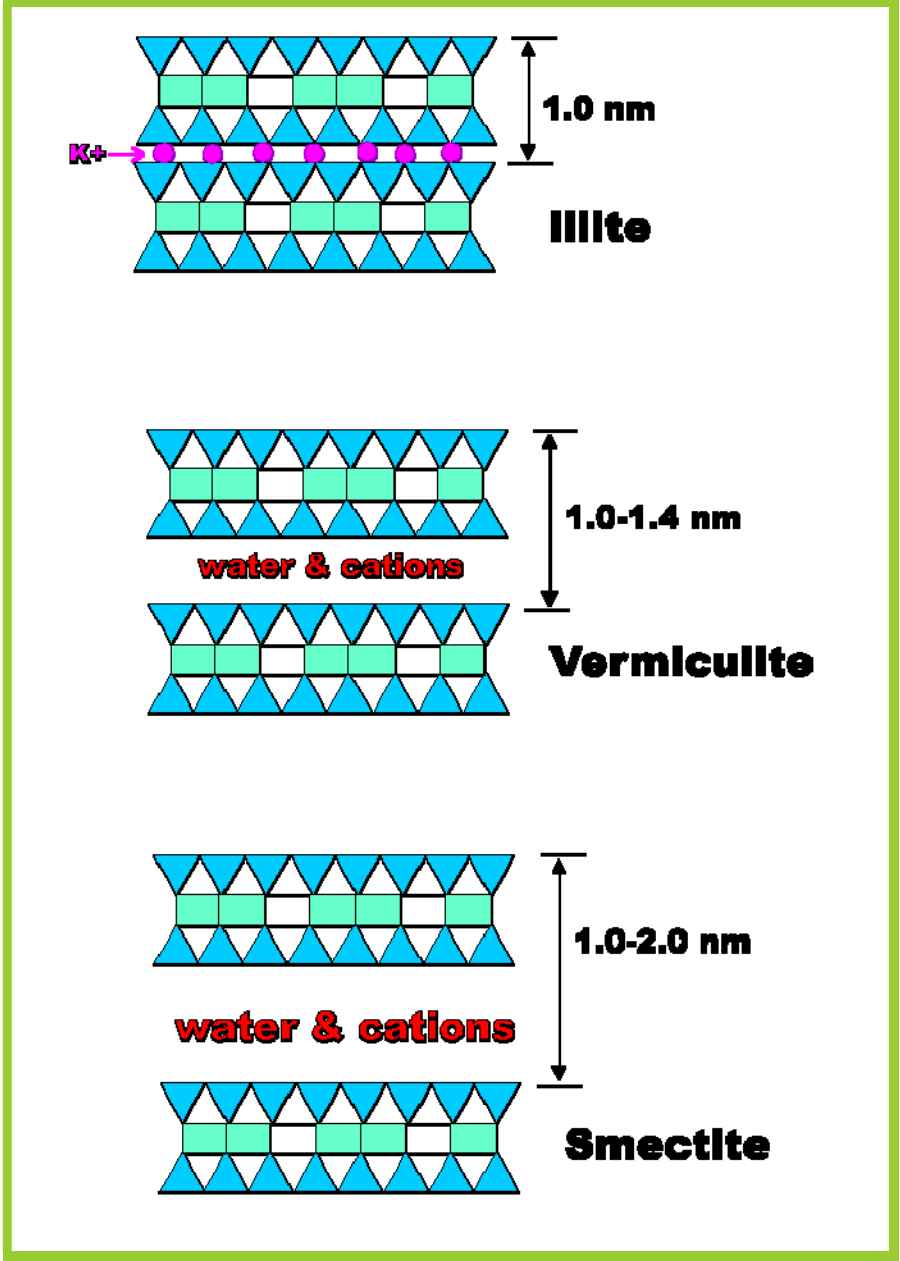

2:1 tipi killerin kıyaslaması

Özet

	<u>Büyükük</u> (μm)	<u>Yüzey alanı (m^2/g)</u>		<u>Tabakalar</u> <u>Arası</u> <u>boşluk (nm)</u>	<u>Kasyon</u> <u>adsorbsiyon</u> <u>u</u>
		dış	iç		
Kaolinite	0.1-5.0	10-50	-	0.7	5-15
Smectite	<1.0	70-150	500-700	1.0-2.0	85-110
Vermiculite	0.1- 5.0	50-100	450-600	1.0-1.4	100-120
Illite	0.1-2.0	50-100	5-100	1.0	15-40
Humus	kaplama	-	-	-	100-300

Kil minerallerinin sonu

- Bazıları çok dirençlidir toprakta kalır
- Bazıları diğer kil minerallerine dönüşür
- Erozyonla yıkanır
- ayrışır ve uzaklaşır
- sonunda
 - Fe, Al oksitler olarak kalır
 - Si yıkanır

Gibbsite

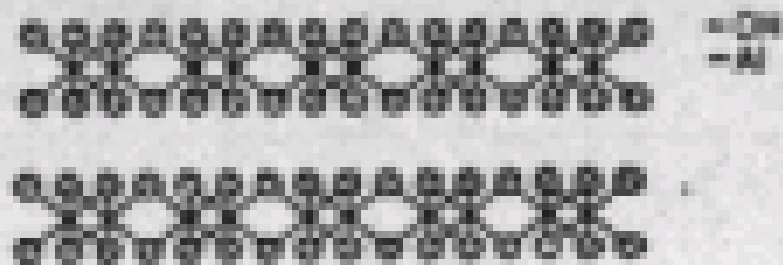
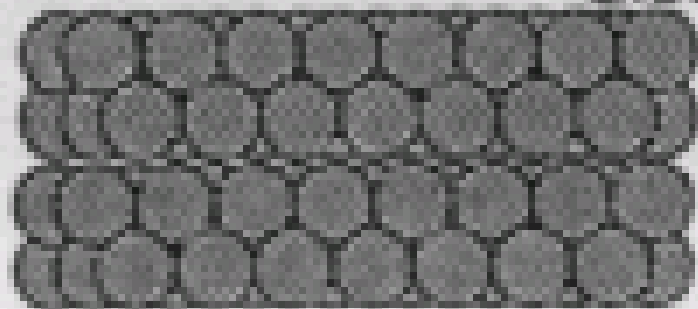

Kaolinite

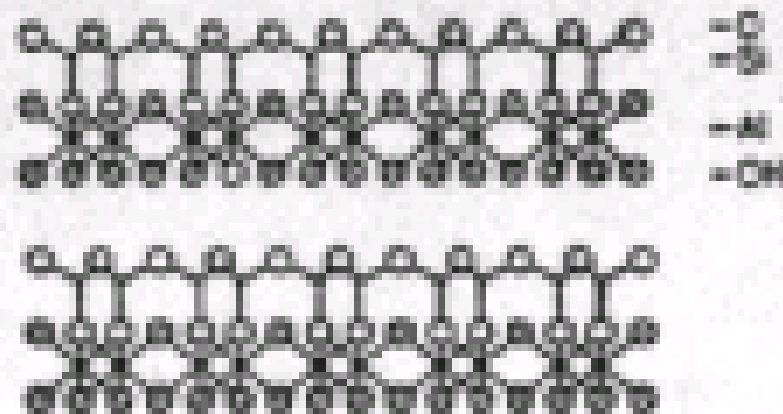
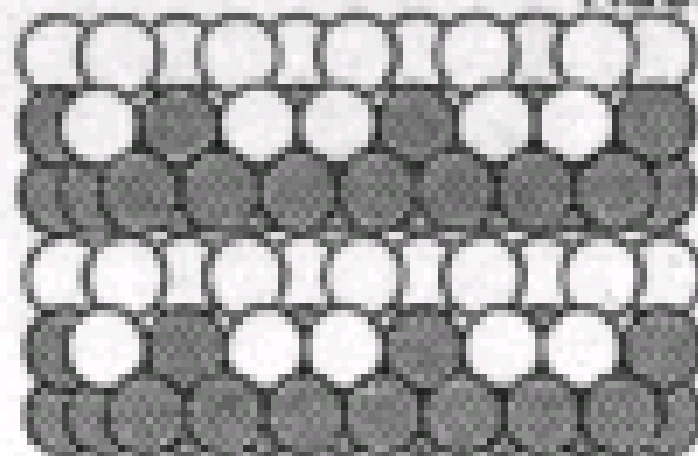

Transformation of micas to Expansible 2:1 Minerals

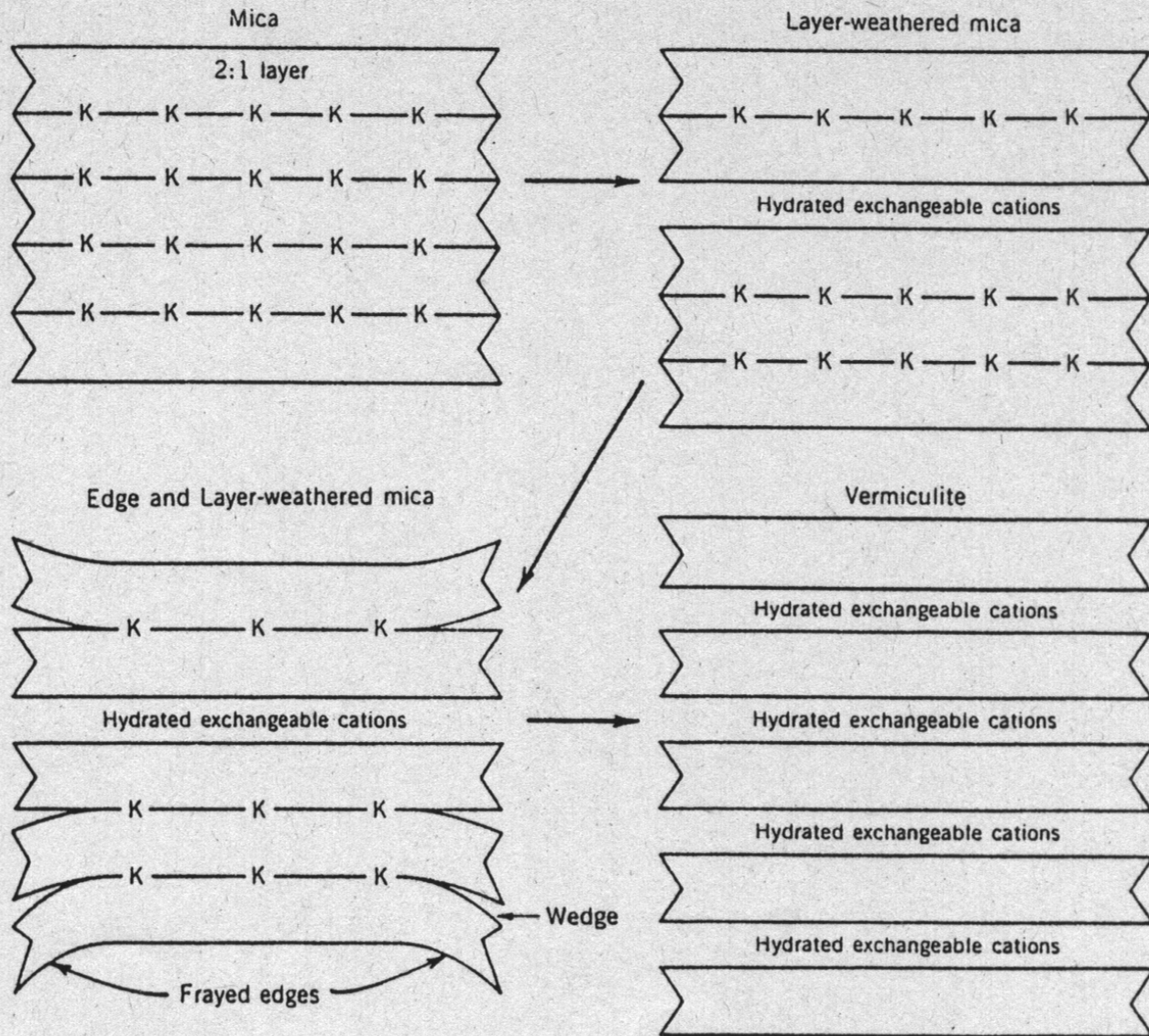

A conceptual weathering scheme for clay minerals

Mineral	Interlayer	Octahedral Cations	Tetrahedral Cations	Coordinated Anions	Charge per. F.W.	C.E.C. cmol/kg
Muscovite mica (primary)	K	Al ₂	Si ₃ Al	O ₁₀ (OH) ₂	1.0	—
Vermiculite	exch. Ca, Mg, Na, etc.	Al ₂	Si _{3.2} Al _{0.8}	O ₁₀ (OH) ₂	0.9-0.6	~160
Smectite (beidellite)	exch. Ca, Mg, K, Na, etc.	Al ₂	Si _{3.5} Al _{0.5}	O ₁₀ (OH) ₂	0.6-0.2	~110
Hydroxy-interlayered smectite	non-exch. Al, exch. Al, Ca, Mg, K, etc.	Al ₂	Si _{3.5} Al _{0.5}	O ₁₀ (OH) ₂	—	100-30
Kaolinite	none	Al ₂	Si ₂	O ₅ (OH) ₄	0	~3
Gibbsite	none	Al	—	(OH) ₃	0	~3

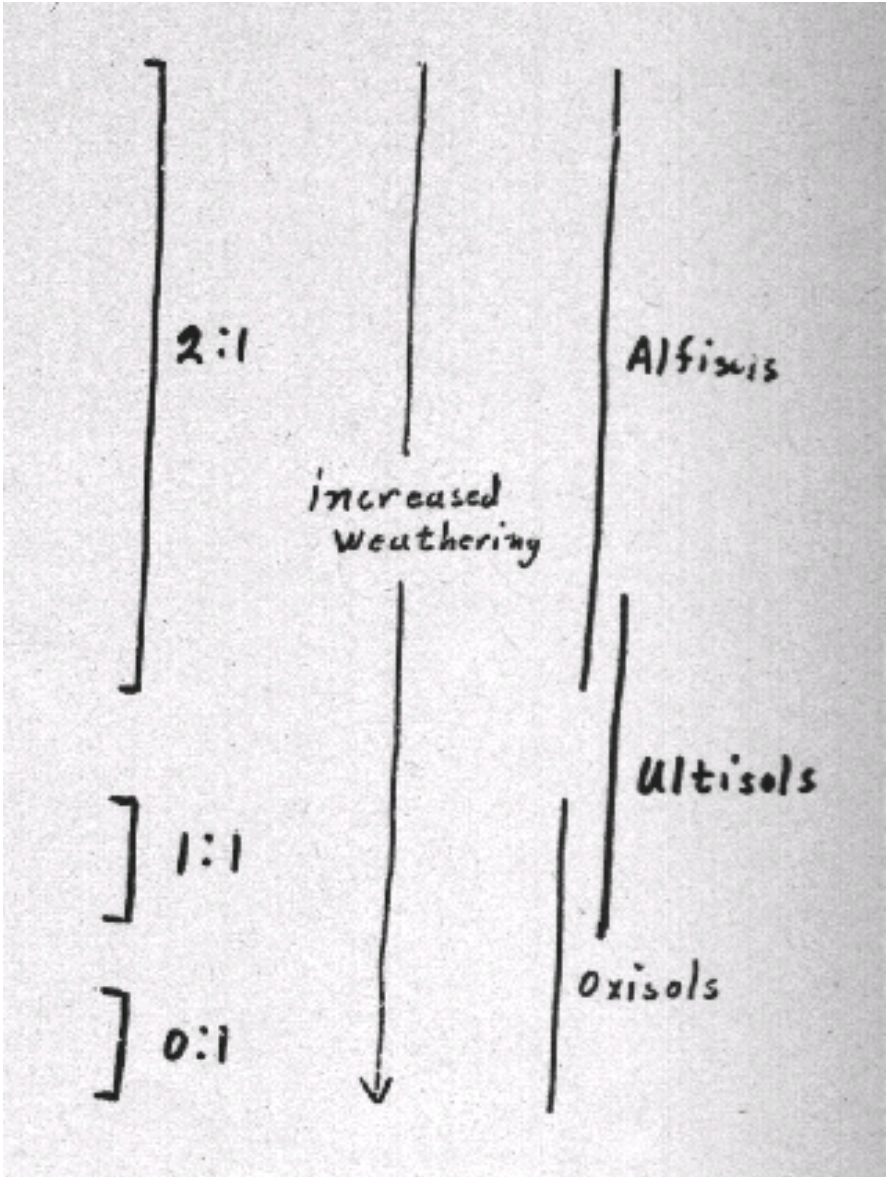

Different Secondary Minerals can Form from the Same Primary Mineral under Different Weathering Conditions

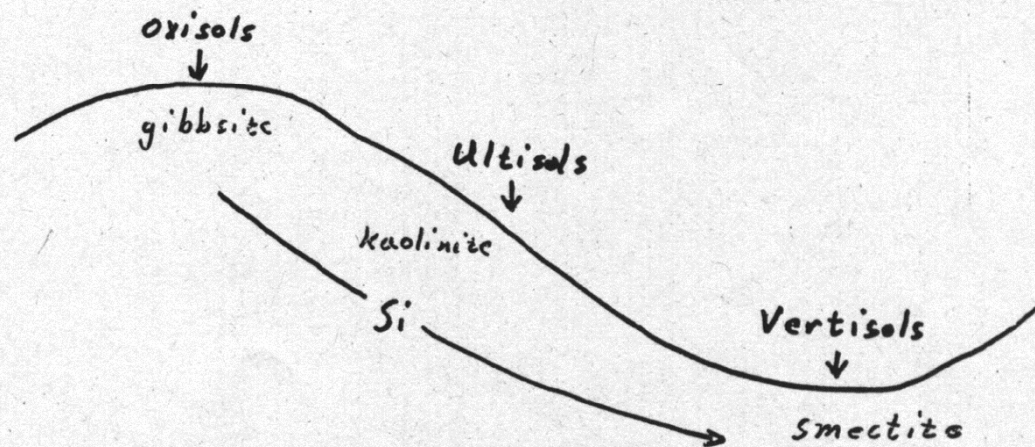
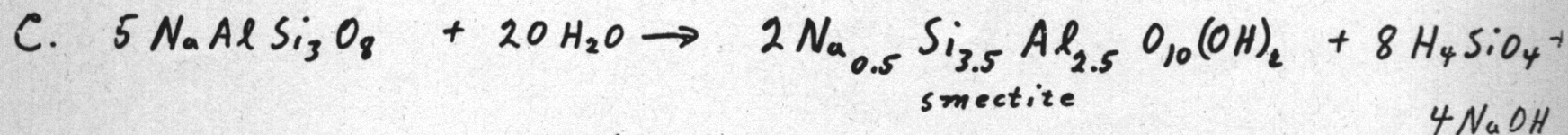
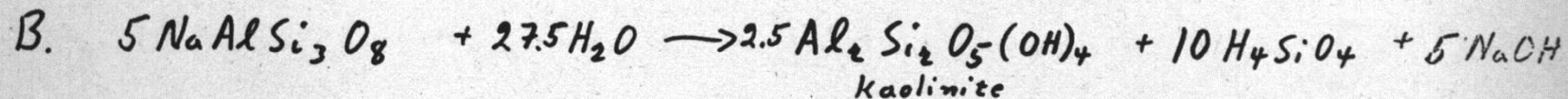
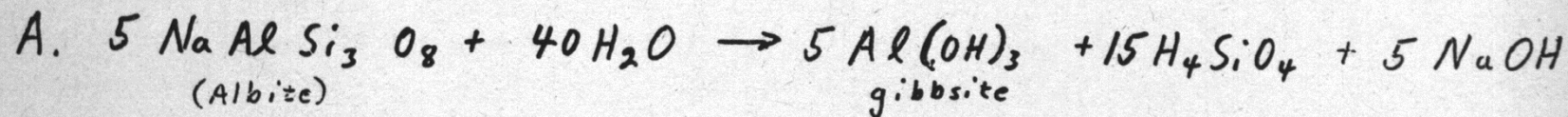

Halloysite

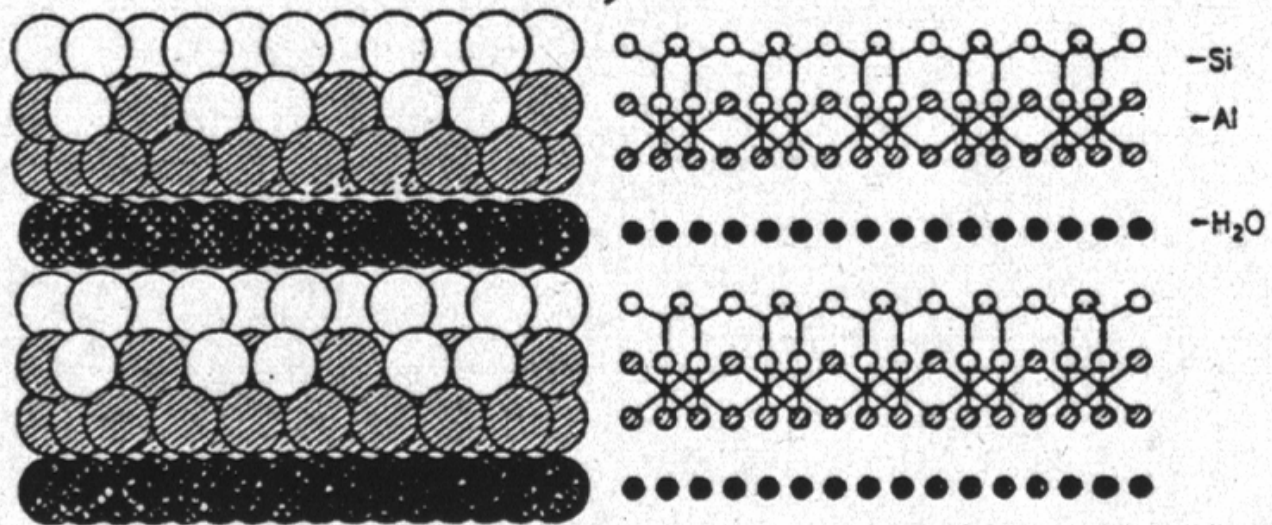

Pyrophyllite

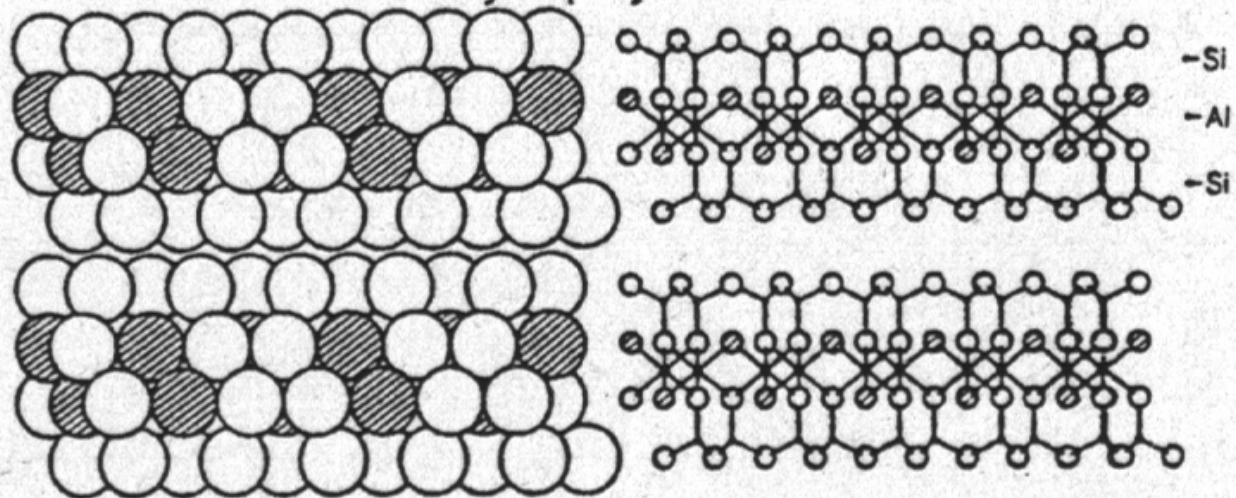

Mica

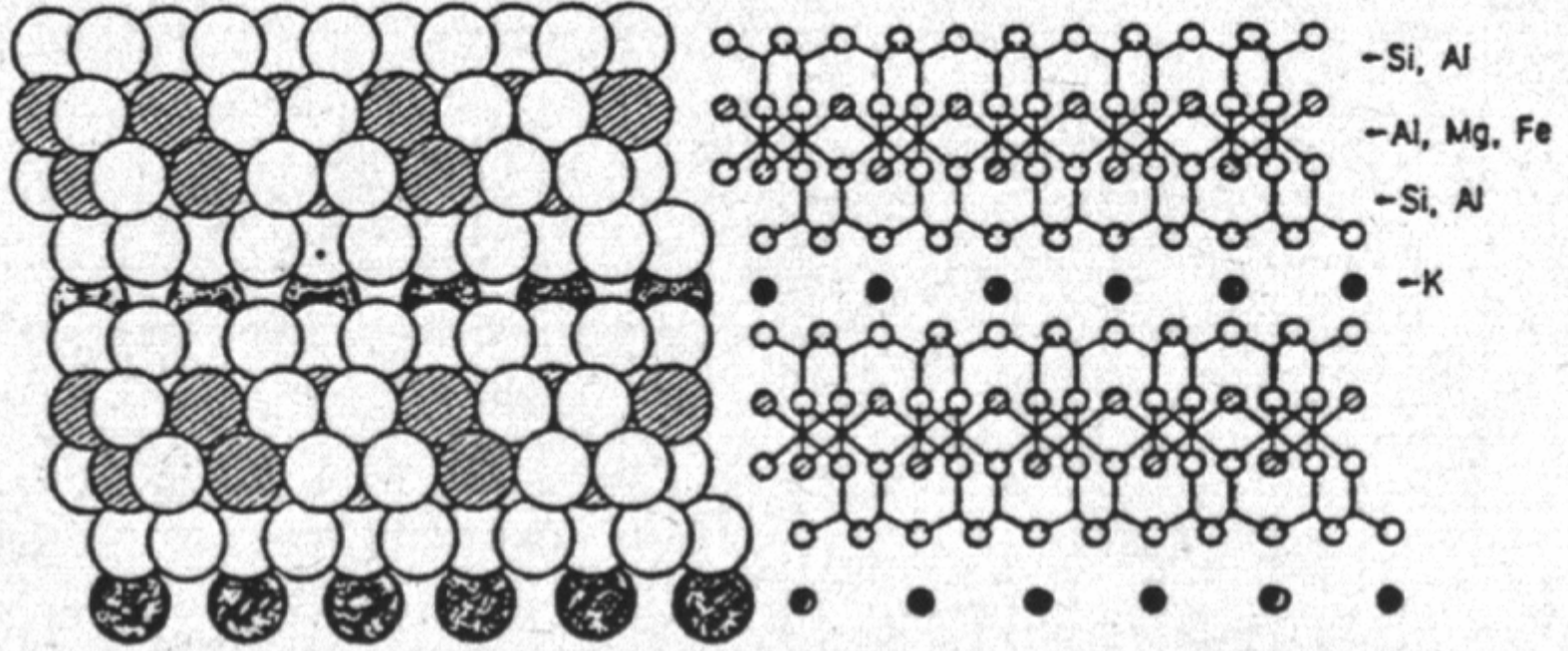

Vermiculite & Smectite

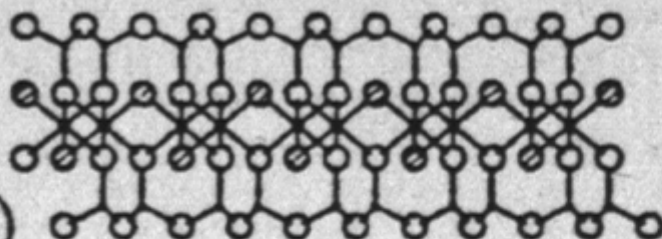
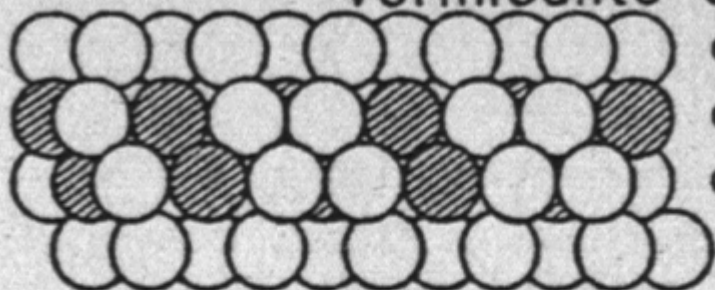

-Si, Al

-Al, Mg, Fe

-Si, Al

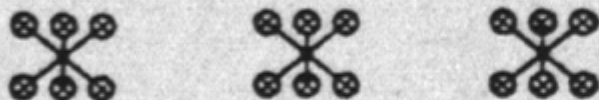
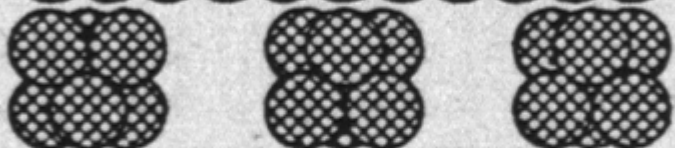

-H₂O

-exch. Ca, Mg, Na, etc.

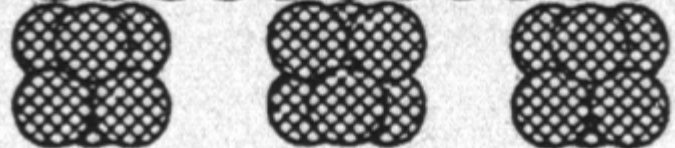
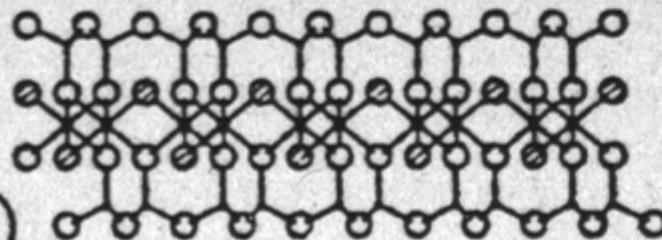
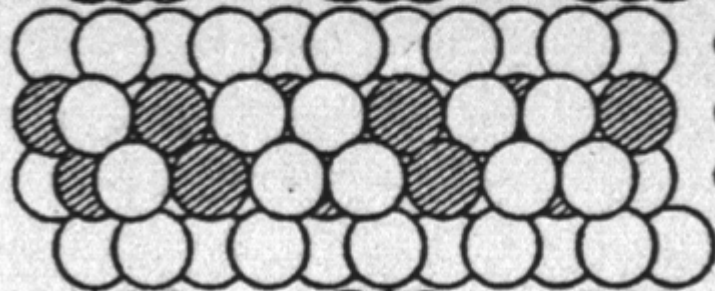

Chlorite

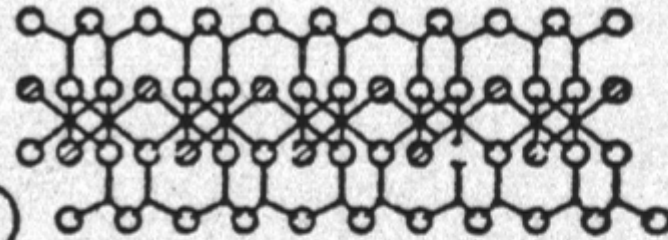
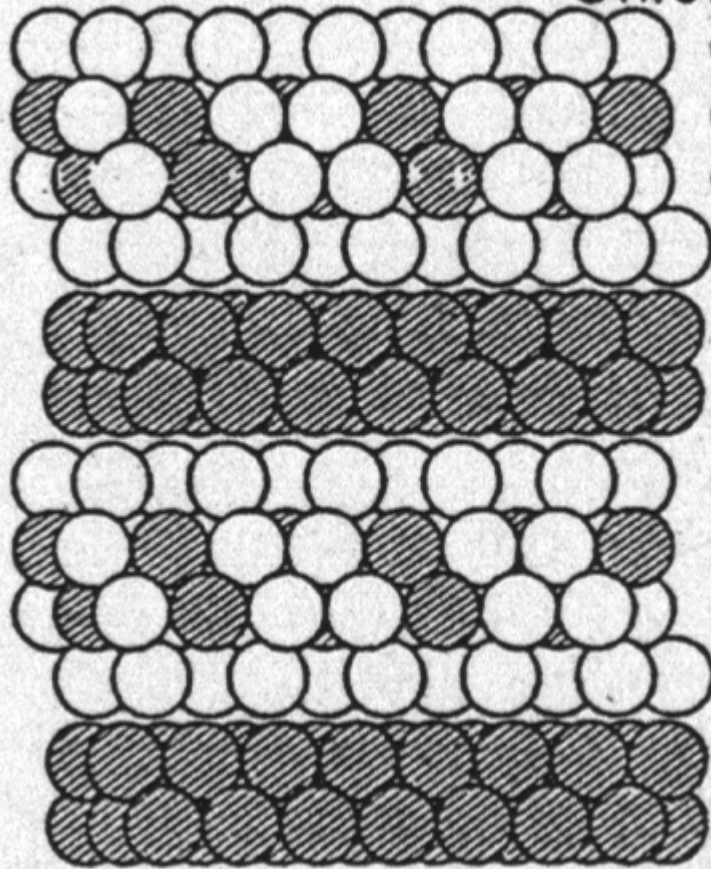

-Si, Al

-Al, Mg, Fe

-Si, Al

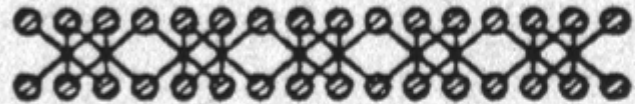

-Al, Mg, Fe

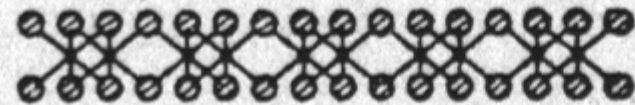
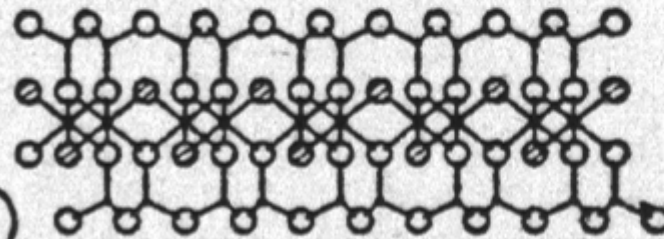

Hydroxy-interlayered Vermiculite & Smectite

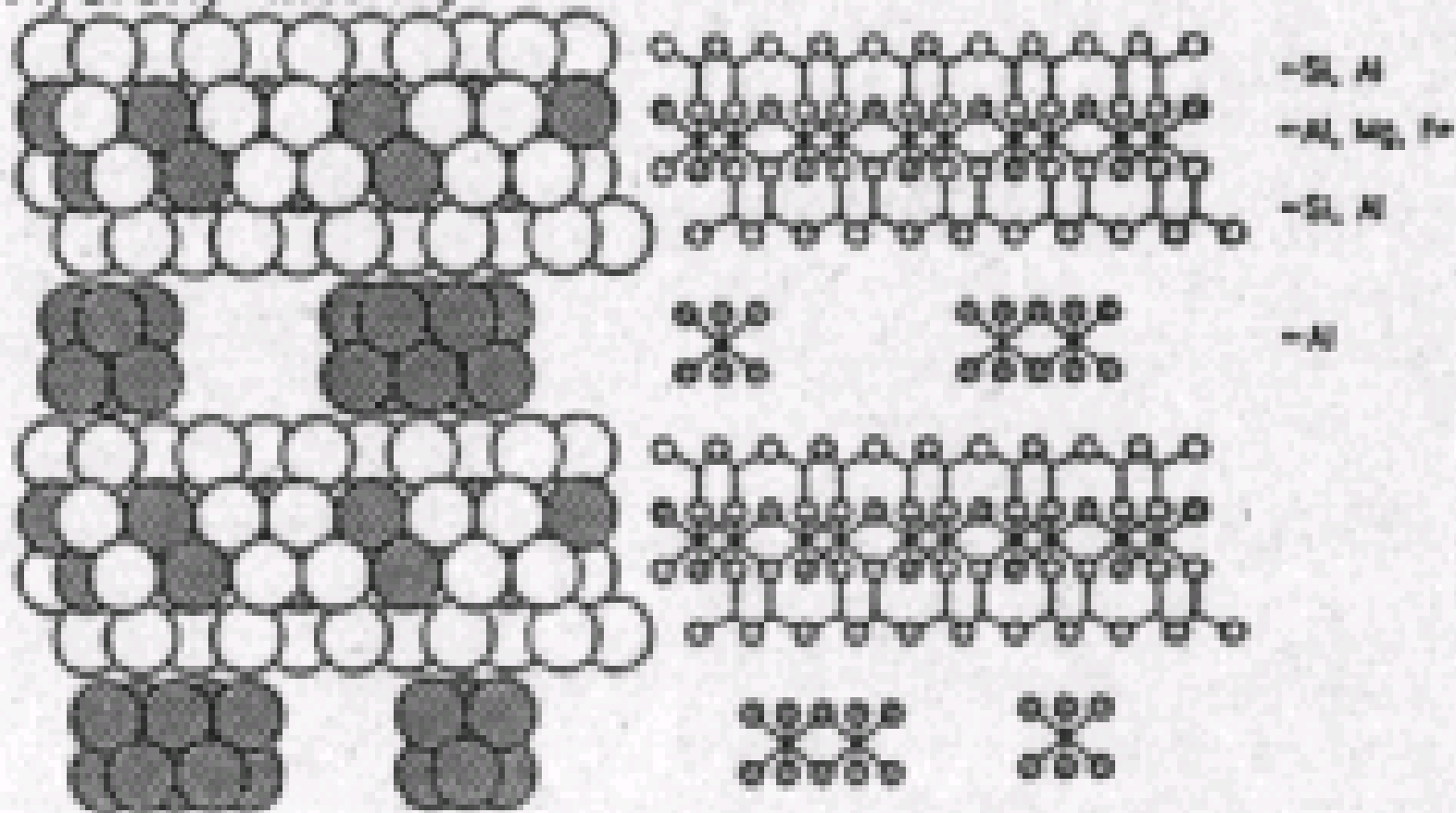

Bu metodun en önemli sınırlaması, fazla miktarda amorf unsurlar bulunan durumlarda belli bir pik elde edilmemesidir. Şekil 3.18 de tipik bir kil mineraline ait x-ışın difraktogramı görülmektedir.

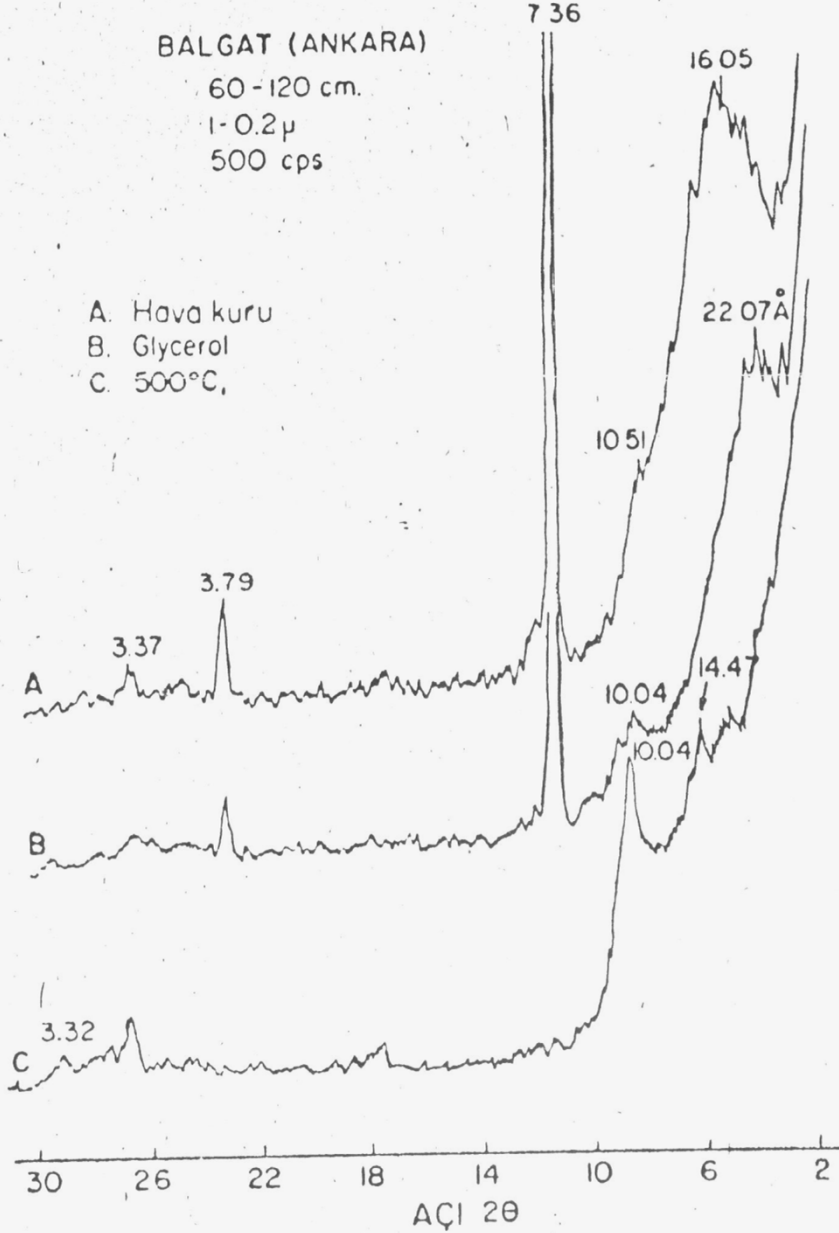

Şekil 3.18. Bir kil mineraline ait x-ışın difraktogramı (Munsuz, 1974).