



Ankara University
Department of Geological Engineering



GEO222 STATICS and STRENGTH of MATERIALS

Lecture Notes

Assoc. Prof. Dr. Koray ULAMIŞ

SIMPLE AXIAL STRESS – 2D

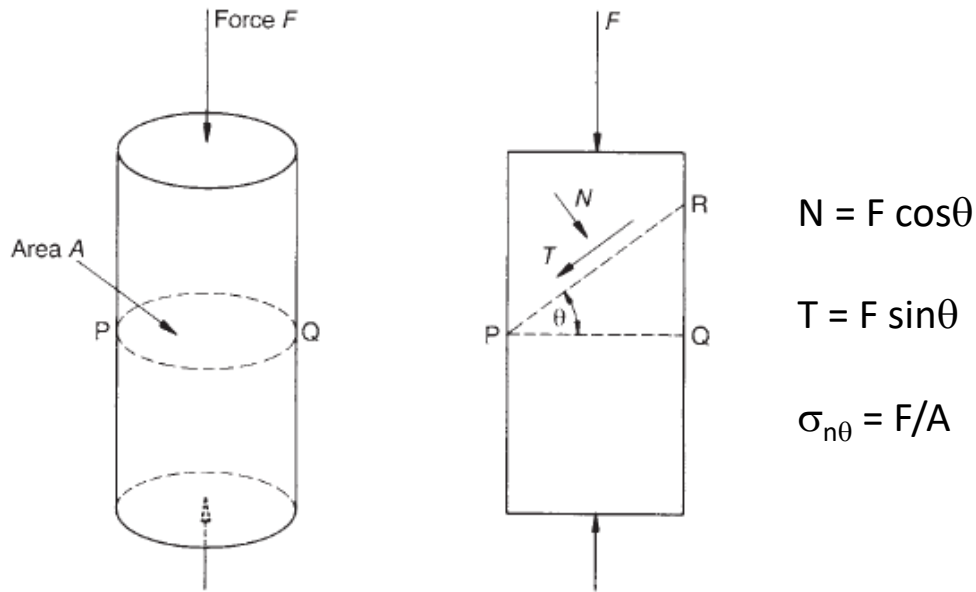

The inclined plane has an area of $A/\cos\theta$; the stress normal to the plane and shear stress along the plane (in the direction of maximum inclination) are;

$$\sigma_{n\theta} = \frac{N \cos \theta}{A} = \frac{F}{A} \cos^2 \theta$$

$$\tau_{\theta} = \frac{T \cos \theta}{A} = \frac{F}{2A} \sin 2\theta$$

The maximum normal stress (s) is F/A which acts on radial planes. The magnitude and direction of maximum shear stress is extracted from the differentiation;

$$\frac{d\tau_{\theta}}{d\theta} = \frac{F}{A} \cos 2\theta$$

The maximum value of shear stress is obtained by putting $d\tau_{\theta}/d\theta=0$;

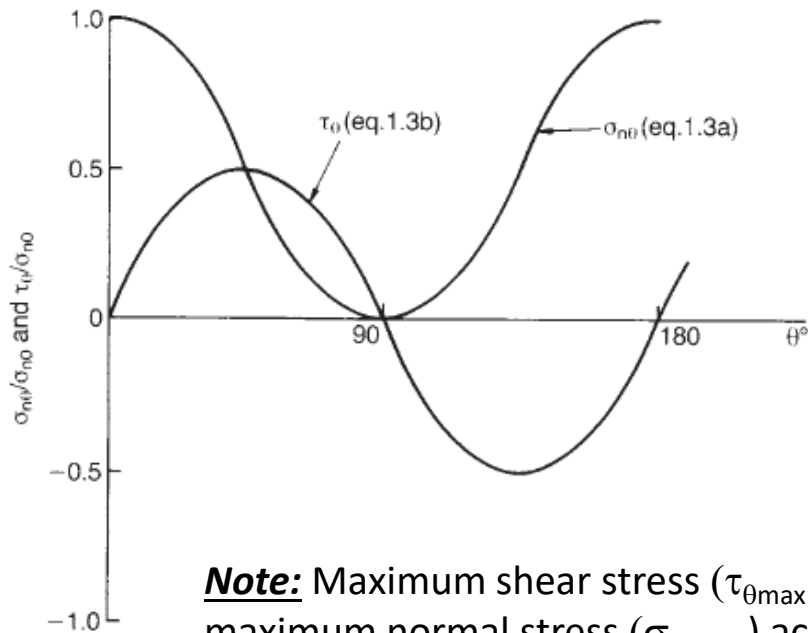

$$\cos 2\theta = 0$$

$$\theta = 45^{\circ} \text{ (or } 135^{\circ}\text{)}$$

$$\tau_{\theta_{\max}} = \frac{F}{2A}$$

Note: Maximum shear stress ($\tau_{\theta_{\max}}$) acts on a plane with $\theta=45^{\circ}$ and maximum normal stress ($\sigma_{n\theta_{\max}}$) acts on a plane with $\theta=0^{\circ}$.

Problem

A cylindrical rock sample is subjected to an axial compressive force of 5kN. The diameter of the sample is 50 mm. Please determine;

- Normal stress and shear stress on an inclined plane of 30° .
- Maximum shear stress
- Inclination of planes on which the shear stress is half of maximum shear stress.

Solution

a. Unit area; $A = \pi r^2 = 1.96 \times 10^{-3} \text{ m}^2$

Normal stress; $\sigma_{n\theta} = (5 \text{ kN} / 1.96 \times 10^{-3}) \cos^2 30 = 1913 \text{ kPa}$

Shear stress; $\tau_\theta = (5 \text{ kN} / 2 \times 1.96 \times 10^{-3}) \sin 60 = 1105 \text{ kPa}$

b. Maximum Shear stress;

$$\tau_{\theta\max} = (F/2A) = (5 \text{ kN} / 2 \times 1.96 \times 10^{-3}) = 1275 \text{ kPa}$$

c. Maximum Shear stress;

$$1/2 \tau_{\theta\max} = \tau_\theta \max \sin 2\theta; \theta = 15^\circ \text{ or } 75^\circ$$

SIMPLE BIAXIAL STRESS – 2D

Consider a rectangular plate (a) of unit thickness with normal principal stresses σ_1 and σ_2 . The shear stresses along the edges are assumed to be zero. A square element of the plate is shown in 2D (b). The normal and shear stresses acting on a plane inclined at an angle θ direction of the plane on which σ_1 acts are found by considering forces acting on the triangular element (c).

Unit length along CD = l , normal stress for a plate of unit thickness

$$F_1 = \sigma_1 l$$

$$N_1 = \sigma_1 l \cos \theta$$

$$T_1 = \sigma_1 l \sin \theta$$

$$F_2 = \sigma_2 l \tan \theta$$

$$N_2 = \sigma_2 l \tan \theta \sin \theta$$

$$T_2 = \sigma_2 l \tan \theta \cos \theta$$

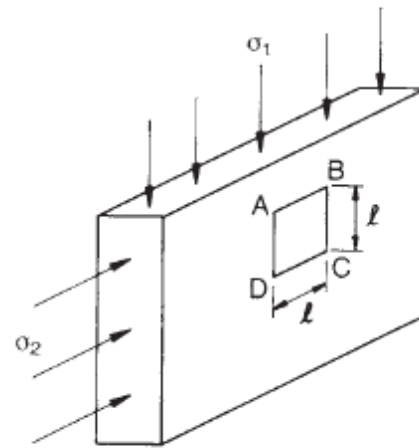

(a)

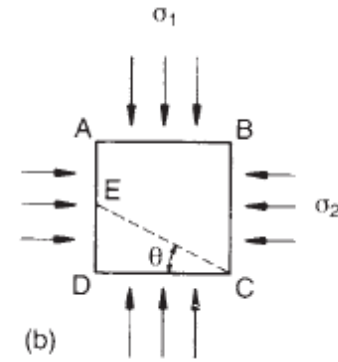

(b)

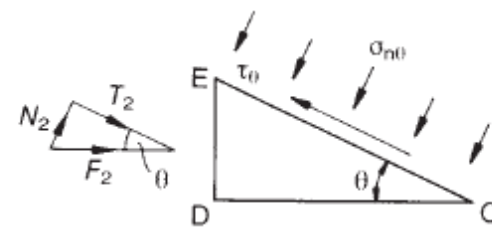

(c)

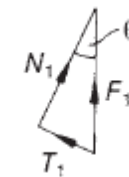

Forces in normal stress direction

$$\sigma_{n\theta} l \sec \theta = N_1 + N_2$$

$$\sigma_{n\theta} = \sigma_1 \cos^2 \theta + \sigma_2 \sin^2 \theta$$

Forces in shear stress direction;

$$T_1 + T_2 = \tau_{\theta} / \sec \theta$$

$$\tau_{\theta} = \frac{1}{2} (\sigma_1 - \sigma_2) \sin 2\theta$$

$$\tau_{\theta_{\max}} = \frac{1}{2} (\sigma_1 - \sigma_2)$$

Maximum shear stress on 45° plane;

$$\tau_{\theta_{\max}} = \frac{\sigma_1}{2} \text{ if } (\sigma_1 > \sigma_2)$$

Problem

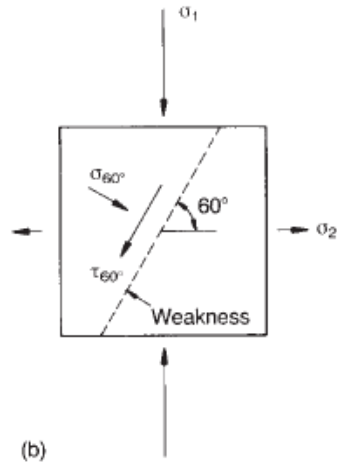
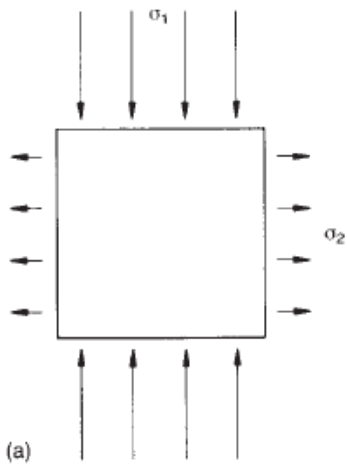

$$\sigma_1 = 0.8 \text{ MPa}$$

and

$$\sigma_1 = 4\sigma_2$$

Solution

Maximum shear stress is on 45° plane;

$$\tau_{\theta_{\max}} = \frac{1}{2}(\sigma_1 - \sigma_2) \sin 2\theta$$

$$\sigma_1 = 1.6 \text{ MPa}$$

and

$$\sigma_2 = 0.4 \text{ MPa}$$

Shear stress is on 60° plane;

$$\tau_{\theta} = \frac{1}{2}(\sigma_1 - \sigma_2) \sin 2\theta$$

$$\tau_{\theta} = 0.866 \text{ MPa}$$

$$\sigma_1 = 1.48 \text{ MPa}$$

and

$$\sigma_2 = 0.37 \text{ MPa}$$

MOHR STRESS CIRCLE

The graphical stress relations was discovered by Culmann (1866) and developed by Mohr (1882) based on the equations given below

$$\cos^2 \theta = \frac{1 + \cos 2\theta}{2}$$

$$\sin^2 \theta = \frac{1 - \cos 2\theta}{2}$$

$$\sin^2 2\theta + \cos^2 2\theta = 1$$

$$\sigma_{n\theta} - \frac{1}{2}(\sigma_z + \sigma_y) = \frac{1}{2}(\sigma_z - \sigma_y) \cos 2\theta + \tau_{zy} \sin 2\theta$$

$$\left[\sigma_{n\theta} - \frac{1}{2}(\sigma_z + \sigma_y) \right]^2 + \tau^2_{\theta} = \left[\frac{1}{2}(\sigma_z - \sigma_y) \right]^2 + \tau^2_{zy}$$

Which is the equation of a circle with radius "r" and with a center on "τ-σ" plot

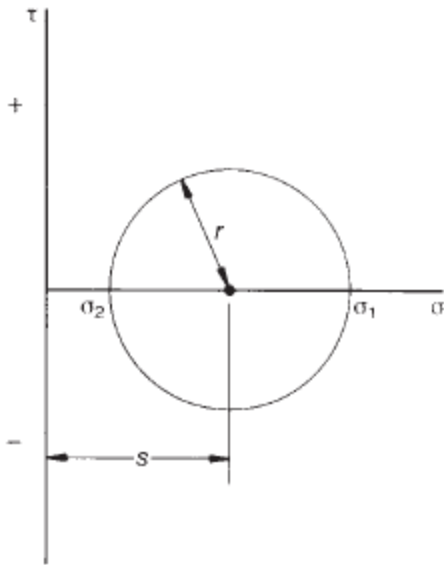

(a)

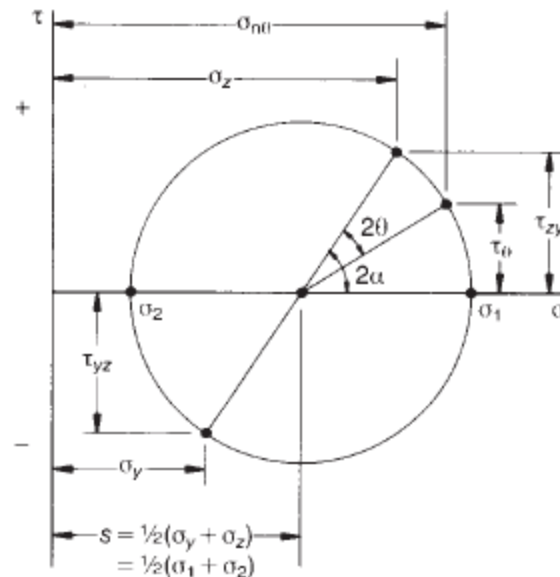

(b)

$$\left(\sigma_{n\theta} - s \right)^2 + \tau^2_{\theta} = r^2$$

$$s = \frac{1}{2}(\sigma_z + \sigma_y)$$

and

$$r^2 = \left[\frac{1}{2}(\sigma_z - \sigma_y) \right]^2 + \tau^2_{zy}$$

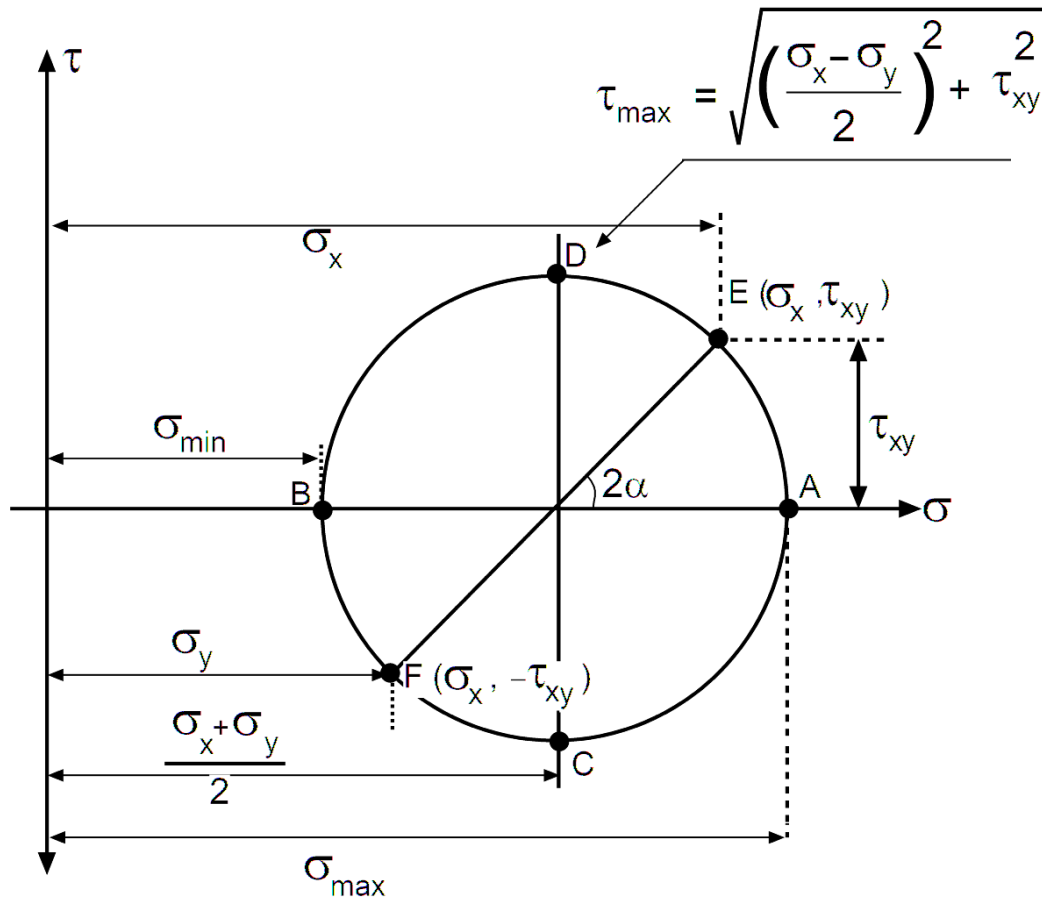

The maximum normal stress is

$$\sigma_{\max} = \left(\frac{\sigma_x + \sigma_y}{2}\right) + \sqrt{\left[\frac{1}{2}(\sigma_x - \sigma_y)\right]^2 + (\tau_{xy})^2}$$

The minimum normal stress is

$$\sigma_{\min} = \left(\frac{\sigma_x + \sigma_y}{2}\right) - \sqrt{\left[\frac{1}{2}(\sigma_x - \sigma_y)\right]^2 + (\tau_{xy})^2}$$

Biaxial Compression-2D

Biaxial stresses are represented by a circle which plots in “ σ ” space, passing through σ_1 and σ_2 on “ $\tau=0$ ” axis. Centre of circle is on “ $\tau=0$ ” axis at point “ $1/2(\sigma_1+\sigma_2)$ ”. Radius of circle has the magnitude of “ $1/2(\sigma_1-\sigma_2)$ ” which represents “ τ_{\max} ”

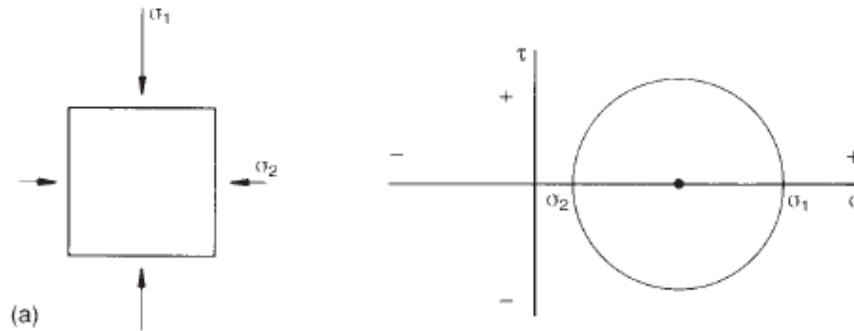

Biaxial Tension-2D

The stress circle extends into both positive and negative “ σ ” space. Center of circle is on “ $\tau=0$ ” axis at point “ $1/2(\sigma_1+\sigma_2)$ ”. Radius is “ $1/2(\sigma_1-\sigma_2)=\tau_{\max}$ ” which occurs at 45° to σ_1 direction. Normal stress is zero in directions “ $\pm\theta$ ” to the direction of σ_1 ;

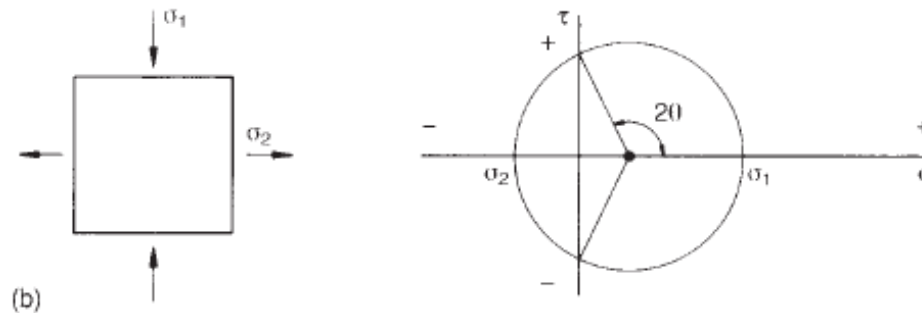

$$\cos 2\theta = -\frac{\sigma_1 + \sigma_2}{\sigma_1 - \sigma_2}$$

Biaxial Shear-2D

The stress circle has a radius of " τ_{zy} " which is opposite to " τ_{yz} ". Center of the circle is at " $\sigma=0; \tau=0$ ". Principal normal stresses " σ_1 and σ_2 " are equal but opposite in sign which have magnitudes equal to " τ_{zy} ". The directions of principal normal stresses are at 45° in directions of " τ_{zy} " and " τ_{yz} ".

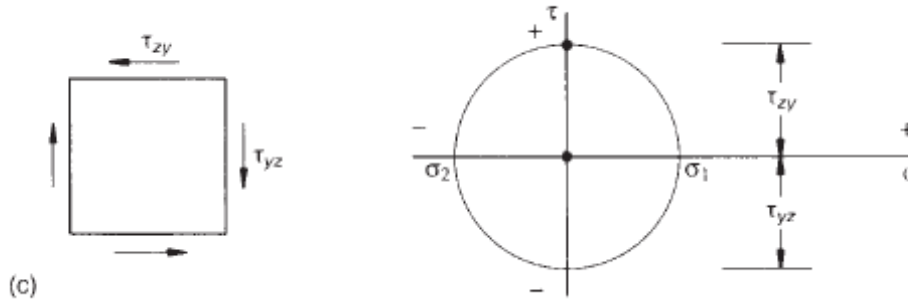

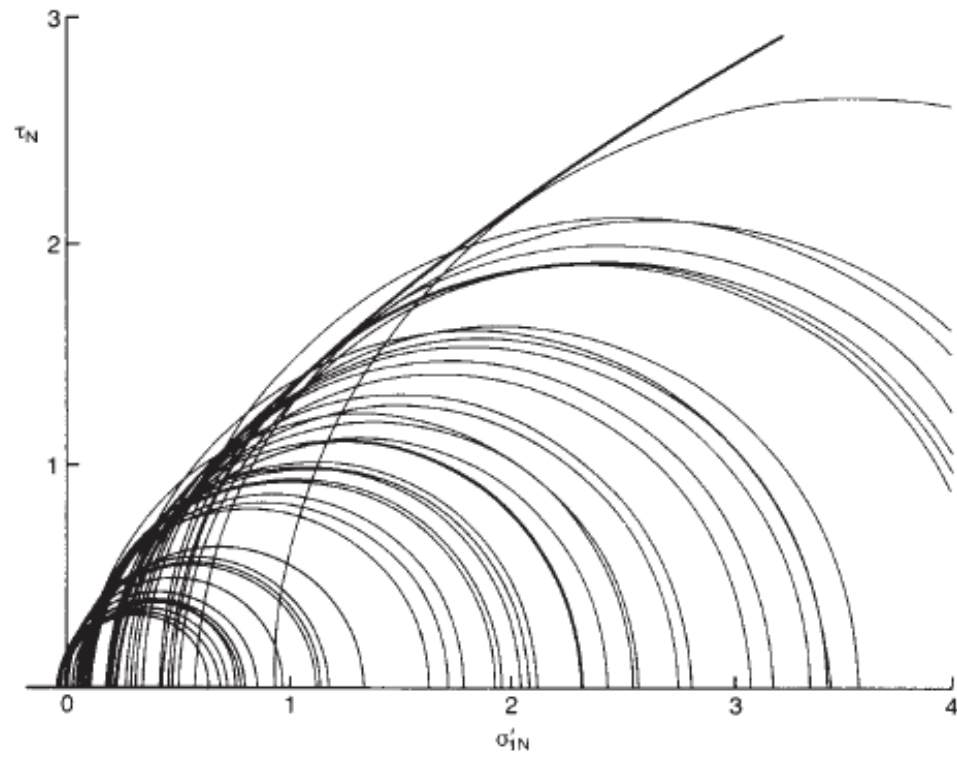

Figure 3.8 Mohr failure circles for five granites. (After Hoek, 1983.)

General Considerations on Principal Stress Relations

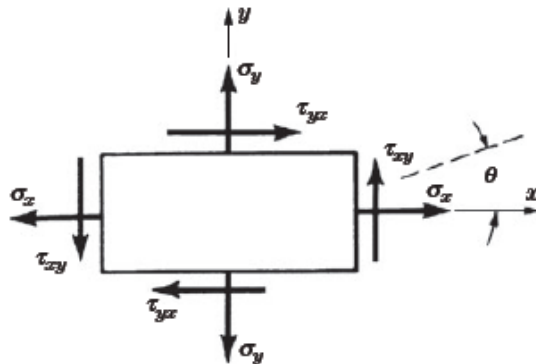

Fig. 3-1 Stresses on a plane element.

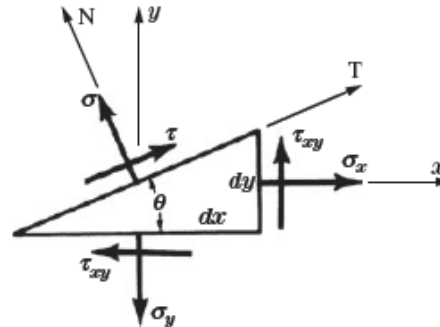

Fig. 3-2 Normal and shearing stresses on an inclined plane.

The maximum normal stress is

$$\sigma_{\max} = \left(\frac{\sigma_x + \sigma_y}{2} \right) + \sqrt{\left[\frac{1}{2}(\sigma_x - \sigma_y) \right]^2 + (\tau_{xy})^2}$$

The minimum normal stress is

$$\sigma_{\min} = \left(\frac{\sigma_x + \sigma_y}{2} \right) - \sqrt{\left[\frac{1}{2}(\sigma_x - \sigma_y) \right]^2 + (\tau_{xy})^2}$$

Problem

A plane element is subjected to the stresses given below. Determine the principal stresses and directions by Mohr's circle.

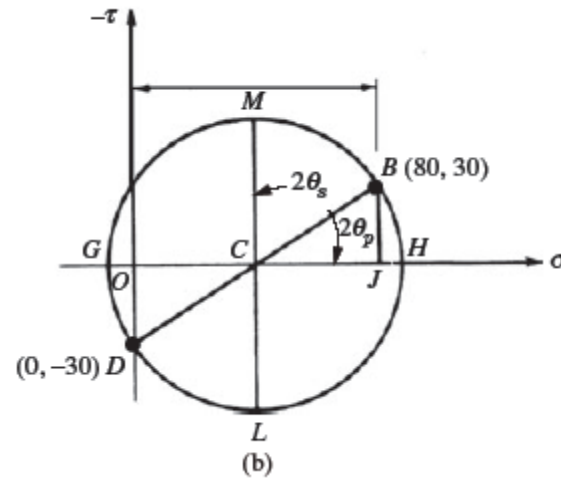
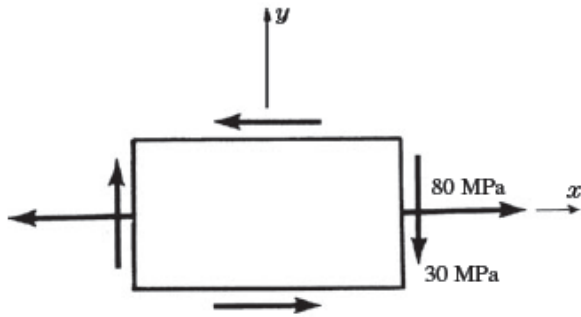

The principal stresses are represented by points G and H. Since the coordinate of "C" is 40;
 $CD = (40^2 + 30^2)^{0.5} = 50$

Minimum principal stress is

$$\sigma_{\min} = OG = OC - CG = 40 - 50 = -10 \text{ Mpa}$$

Maximum principal stress is

$$\sigma_{\max} = OH = OC + CH = 40 + 50 = 90 \text{ Mpa}$$

The angle $2\theta_p$;

$$\tan 2\theta_p = 30/40; \theta_p = 18.43$$

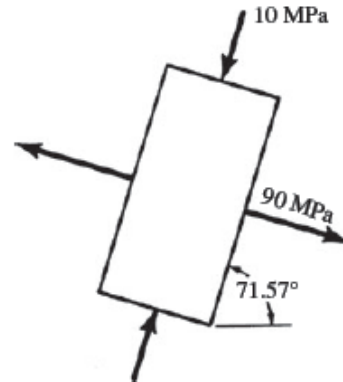

STRESS in 3D

In the body of a stressed material, 3D stresses at any point can be represented as if acting on a small cubical element. The nine stresses in three Cartesian space are in form of a matrix "**STRESS TENSOR**"

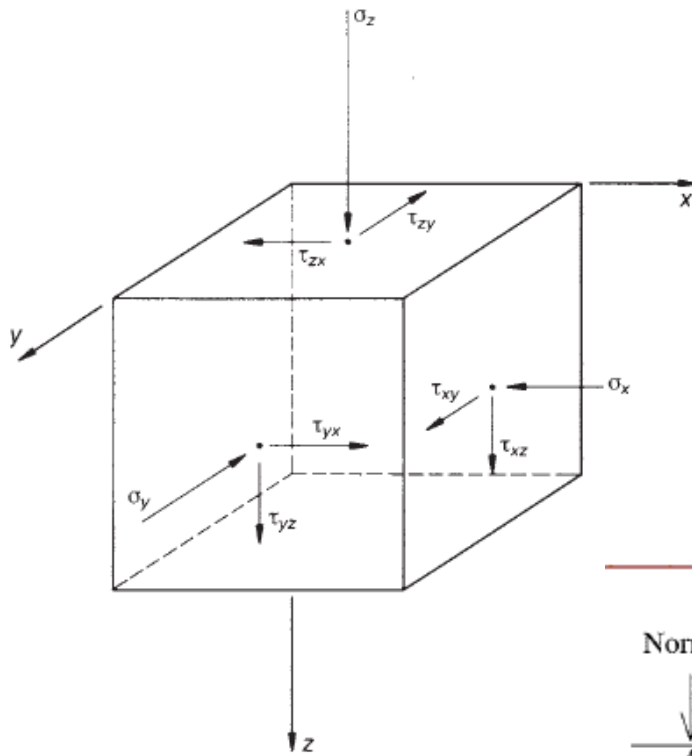

$$T_{\sigma} = \begin{bmatrix} \sigma_z & \tau_{zy} & \tau_{zx} \\ \tau_{yz} & \sigma_y & \tau_{yx} \\ \tau_{xz} & \tau_{xy} & \sigma_x \end{bmatrix}$$

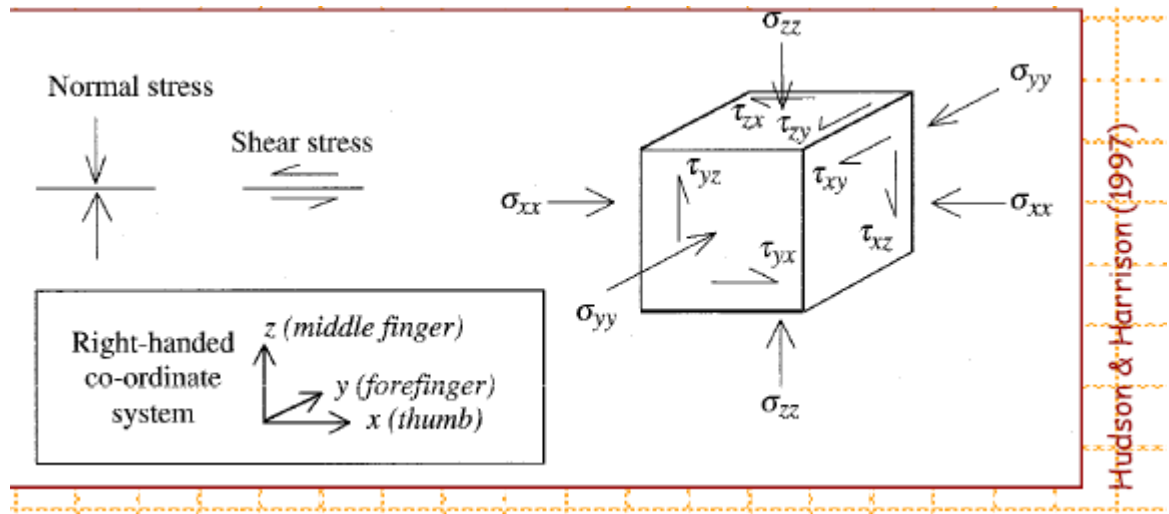

Example #1

Q. Add the following 2-D stress states, and find the principal stresses and directions of the resultant stress state.

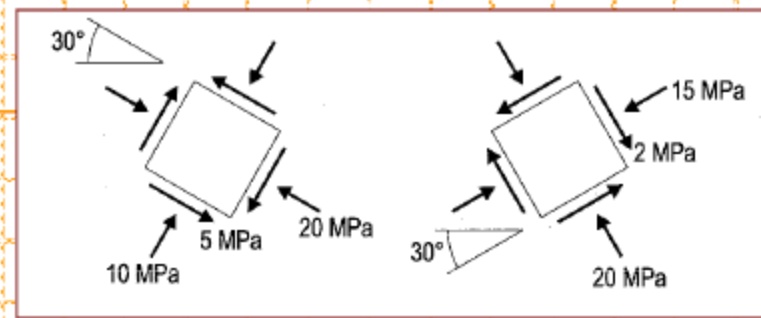

A. Hint: Solve the problem graphically using a Mohr's circle plot.

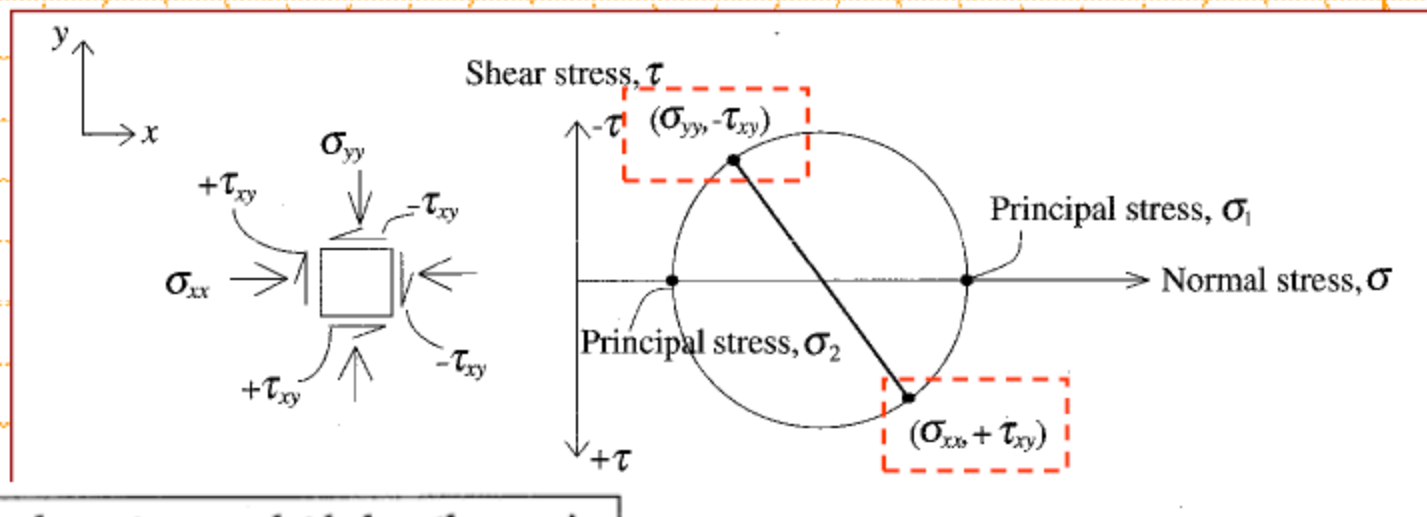

positive shear stresses plot below the σ -axis.

Hudson & Harrison (1997)

Example #1 (Solution)

Q. Add the following 2-D stress states, and find the principal stresses and directions of the resultant stress state.

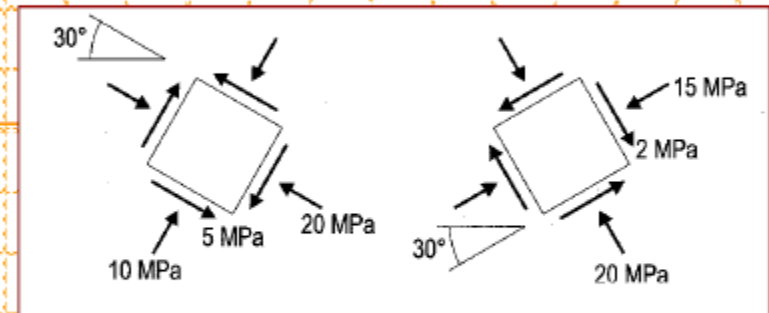

A. Step 1: Draw xy and lm axes for the first stress state, and then plot the corresponding Mohr circle.

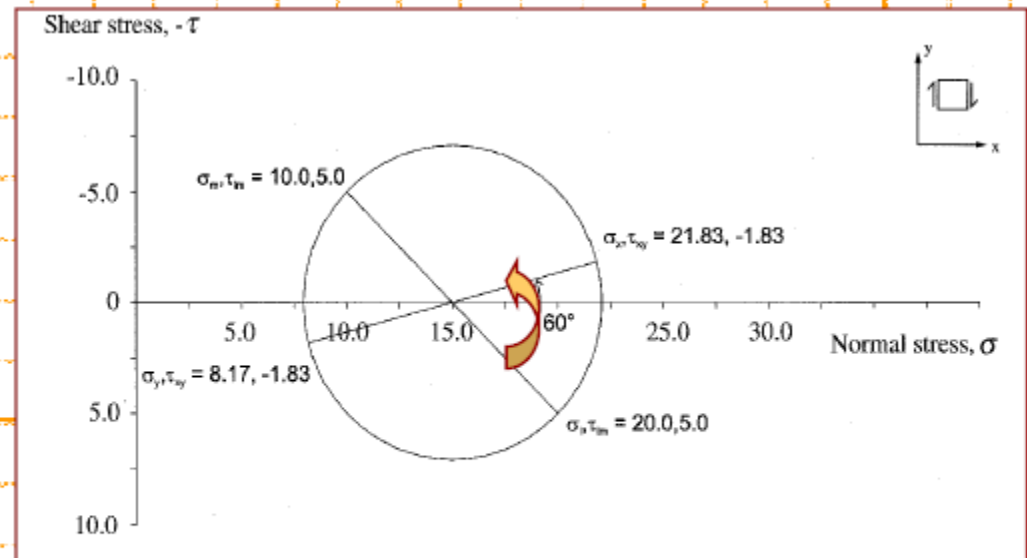
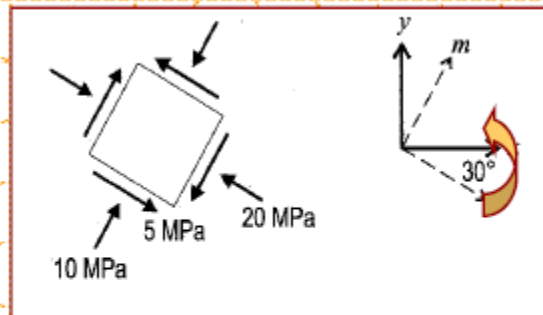

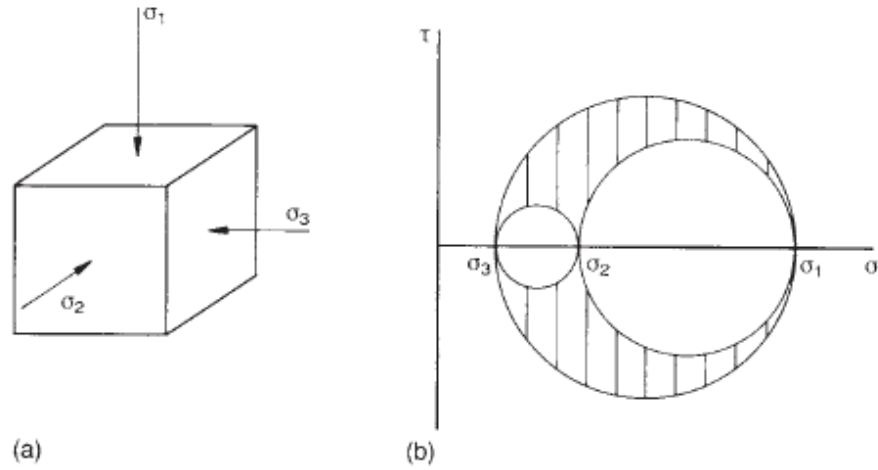

Figure 1.10 Cubical element with principal stresses only acting on its faces: (a) stresses; (b) Mohr circles.

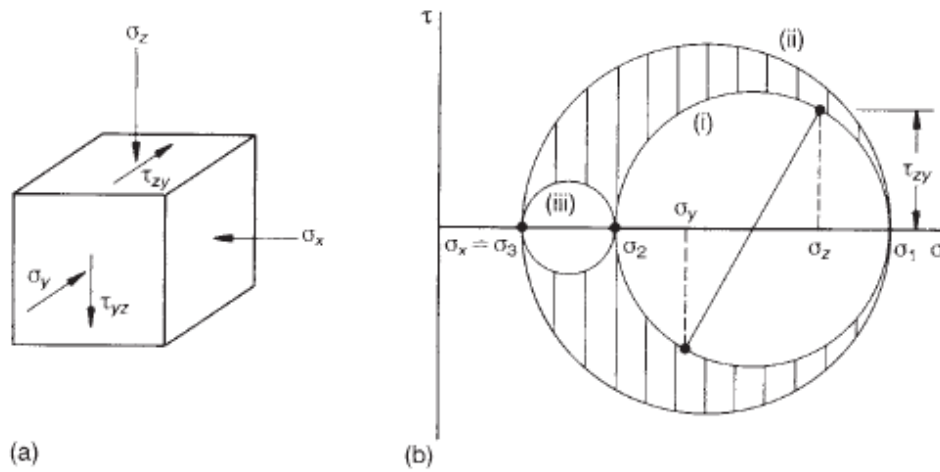
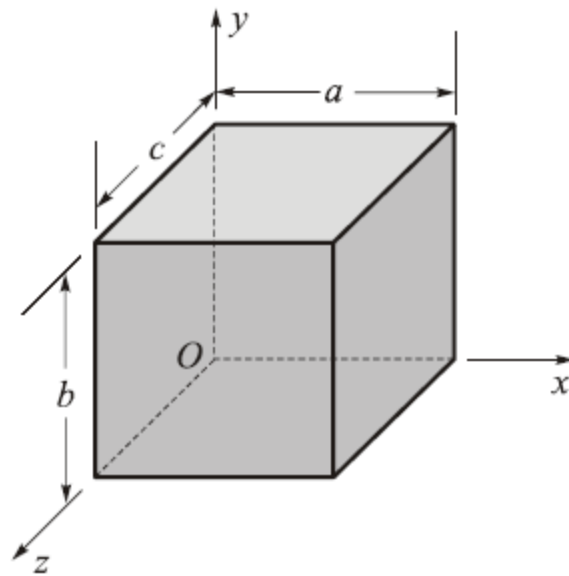

Figure 1.11 Cubical element with normal stresses on all faces and shear stresses on two pairs of opposite faces: (a) stresses; (b) Mohr circles.

5.1 Plane Strain versus Plane Stress Relations

First of all, let us estimate the term “*plane strain*” and its relations to plane stress. Consider a small element of material having sides of lengths a , b , and c in the x , y , and z directions, respectively (Fig. 5.1a). If the only deformations are those in the xy plane, then three strain components may exist: the normal strain ϵ_x in the x direction (Fig. 5.1b), the normal strain ϵ_y in the y direction (Fig. 5.1c), and the shear strain γ_{xy} (Fig. 5.1d). An element of material subjected to these strains is said to be in a *state of plane strain*. It follows that an element in plane strain has no normal strain ϵ_z in the z direction and no shear strains γ_{xz} and γ_{yz} in the xz and yz planes, respectively.



(a)

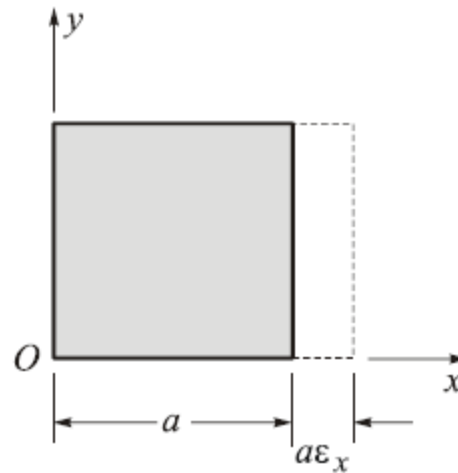

(b)

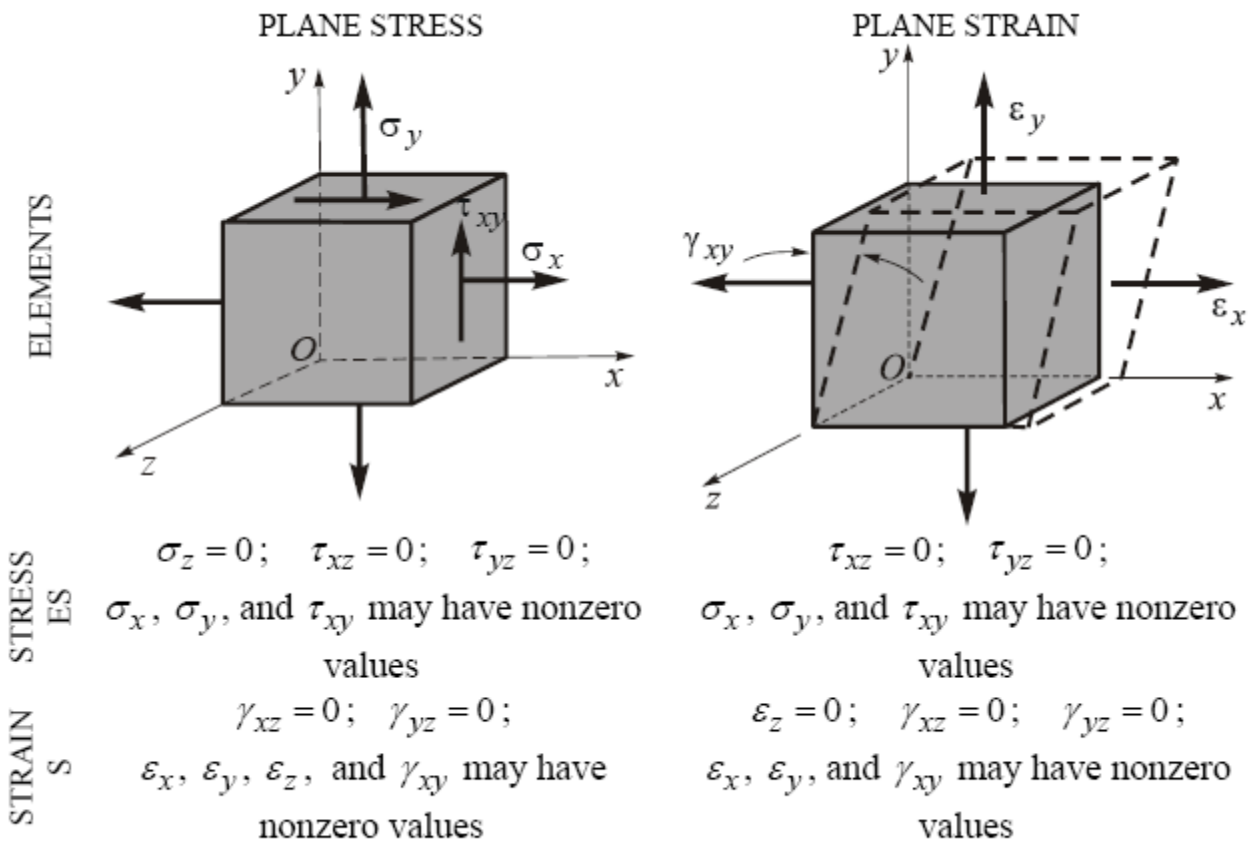

Fig. 5.2 Comparison of plane stress and plane strain

5.3 Principal Strains

Principal strains exist on perpendicular planes with the principal angles θ_p calculated from the following equation (compare with Eq. 3.19):

5.4 Maximum Shear Strains

The maximum shear strains in the xy plane are associated with axes at 45° to the directions of the principal strains. The algebraically maximum shear strain (in the xy plane) is given by the following equation (compare with Eq. 3.38):

$$\frac{\gamma_{\max}}{2} = \sqrt{\left(\frac{\varepsilon_x - \varepsilon_y}{2}\right)^2 + \left(\frac{\gamma_{xy}}{2}\right)^2}. \quad (5.13)$$

The algebraically minimum shear strain has the same magnitude but is negative.

In the directions of maximum shear strain, the normal strains are

$$\varepsilon_{aver} = \frac{\varepsilon_x + \varepsilon_y}{2} = \frac{\varepsilon_1 + \varepsilon_2}{2}. \quad (5.14)$$

Eq. (5.14) is analogous to Eq. (3.40) for stresses.

The *true maximum shearing strain of three-dimensional analysis* proceeds from Eq. (3.39):

$$(\gamma_{\max})_t = \varepsilon_1 - \varepsilon_3. \quad (5.15)$$

Here ε_1 and ε_3 are the algebraically largest and smallest principal strains, respectively.

The maximum out-of-plane shear strains, that is, the shear strains in the xz and yz planes, can be obtained from equations analogous to Eq. (5.13).

An element in plane stress that is oriented to the principal directions of stress (see Fig. 3.17b) has no shear stresses acting on its faces. Therefore, the shear strain $\gamma_{x_1y_1}$ for this element is zero. It follows that the normal strains in this element are the principal strains. Thus, *at a given point in a stressed body, the principal strains and principal stresses occur in the same directions.*

5.5 Mohr's Circle for Plane Strain

Mohr's circle for plane strain is constructed in the same manner as the circle for plane stress, as illustrated in Fig. 5.6. Normal strain ϵ_{x_1} is plotted as the abscissa (positive to the right) and one-half the shear strain $\left(\frac{\gamma_{x_1 y_1}}{2}\right)$ is plotted as the ordinate (positive downward). The center C of the circle has an abscissa equal to ϵ_{aver} (Eq. 5.14).

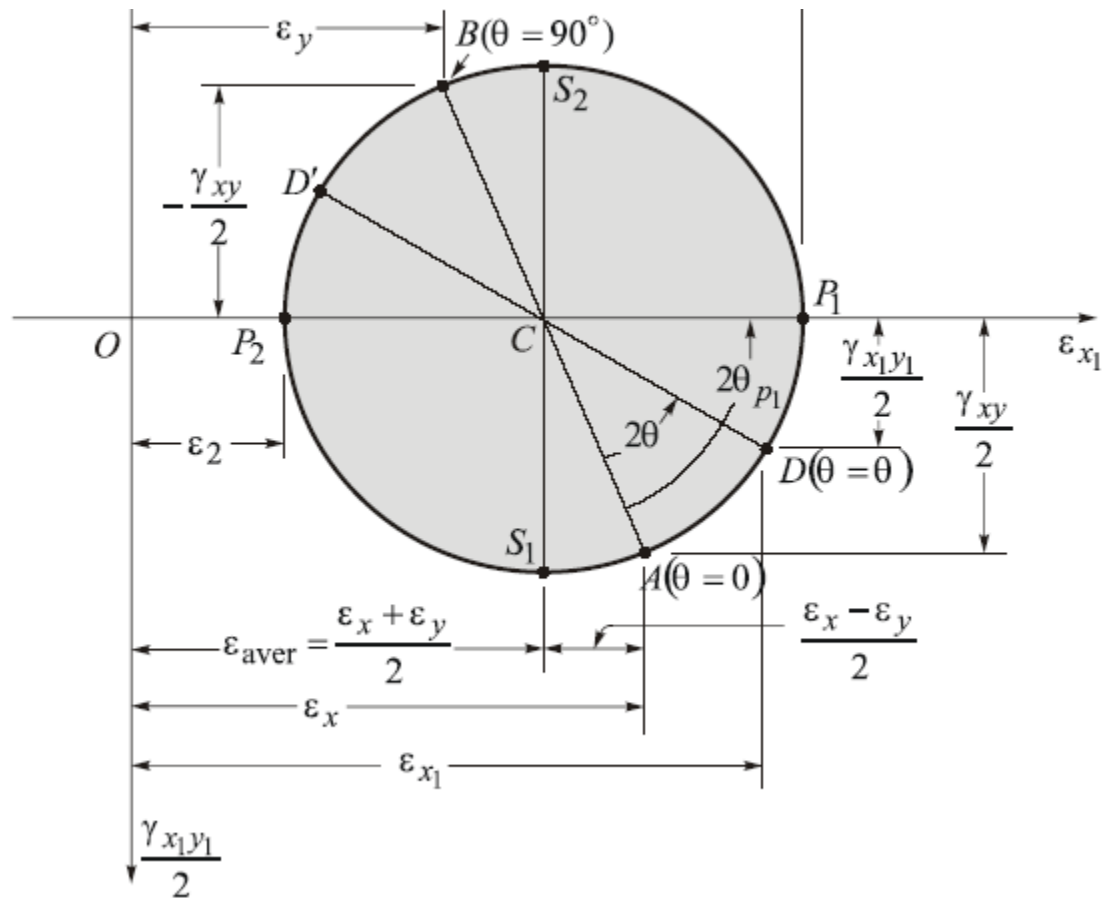

Fig. 5.6 Mohr's circle for plane strain