

**KLA 120**  
**ANTİK MİMARİDE MALZEME - TEKNİK**

**5. Hafta**

**KLA 120**

**ANTİK MİMARİDE MALZEME - TEKNİK**

**TAŞÇI ALETLERİ**

# Taşçı aletleri

Mucarta, Kalem, Tarak, Murç, Tokmak

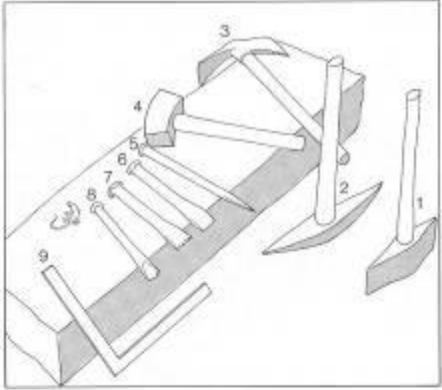

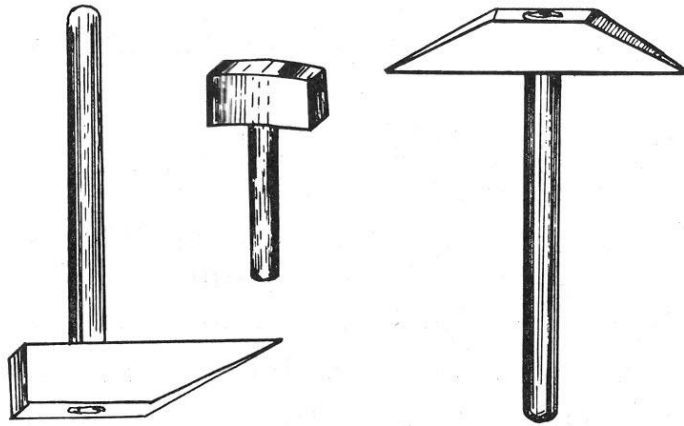

Fig. 70. — Marteaux de tailleur de pierre.

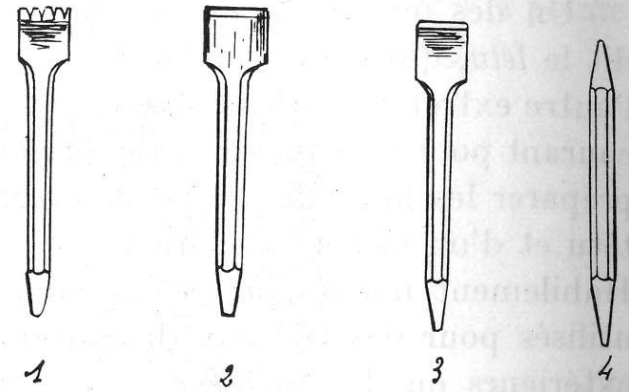
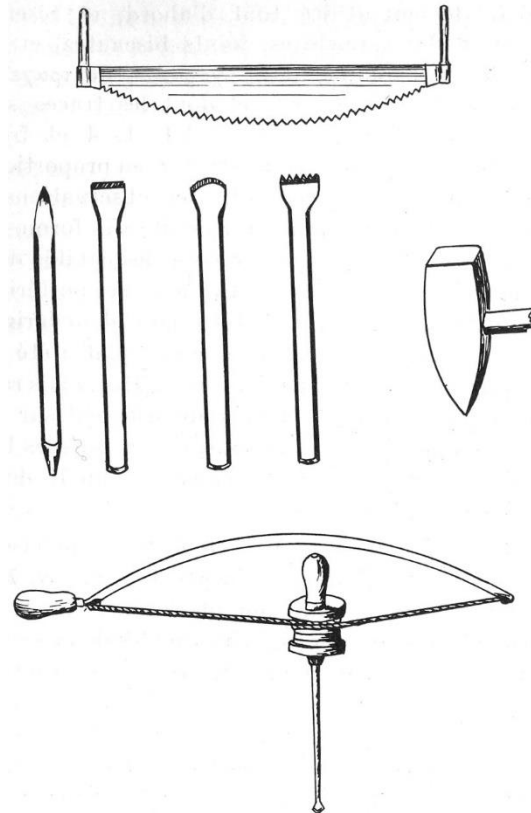

Fig. 71. — Pointes et ciseaux.











# TAŞ YONTMA ALETLERİ



VARYOZ

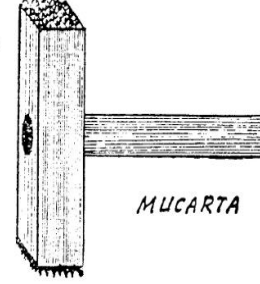

MUCARTA

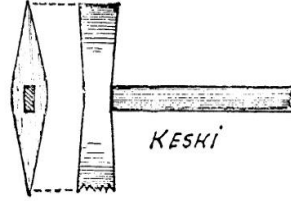

KESKİ

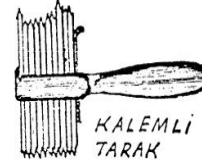

KALEMLİ  
TARAK

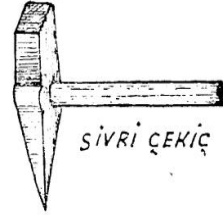

SİVRİ ÇEKİÇ

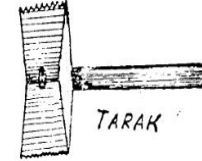

TARAK

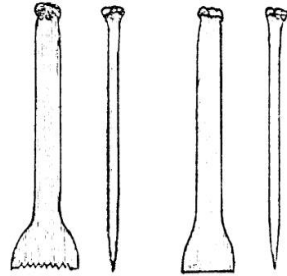

Dişli KALEM

DÜZ KALEM

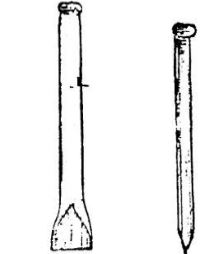

ÇARPAKAK

MURÇ

20 a) Äxte, Hacken und Hämmer: 1-2: Hacken aus Priene und Olympia; 3-5: Äxte aus Olympia und Herculanum; 6: Doppelaxt; 7-9: Hacken aus Priene (z. T. nur für Landbearbeitung); 10: Hammer (Megara Hyblaea)

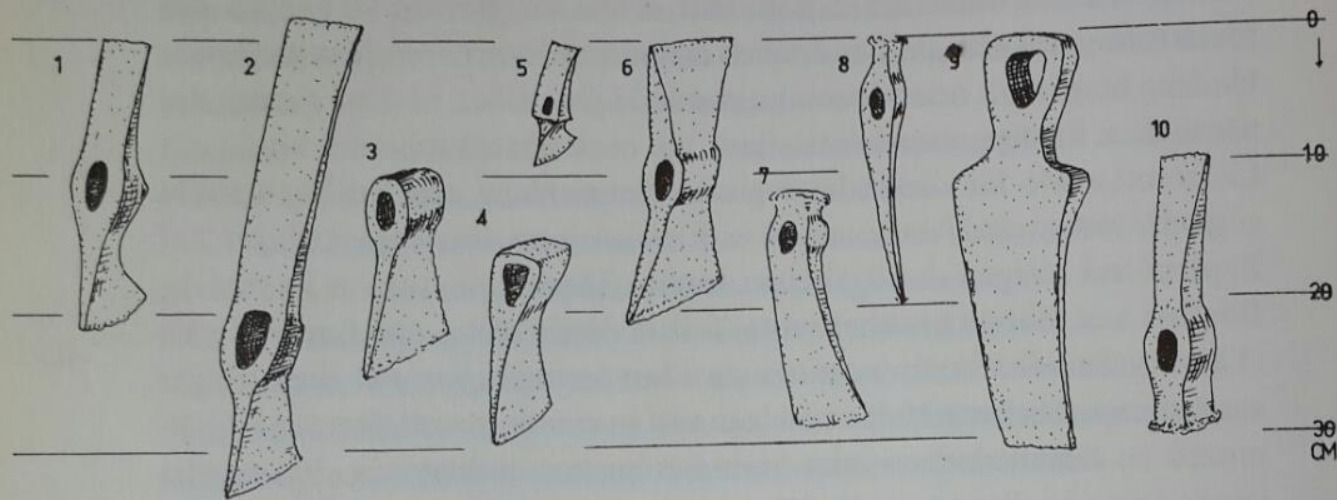

b) Steinmetzwerkzeuge: 1-6: verschiedene Meißel; 7: Doppelaxt (Olympia, E. 5. Jh.); 8: Zirkel (Pompeji); 9: Drillbohrer; 10: Lote; 11: Winkel mit Lot (Tyrus; Mus. du Louvre)

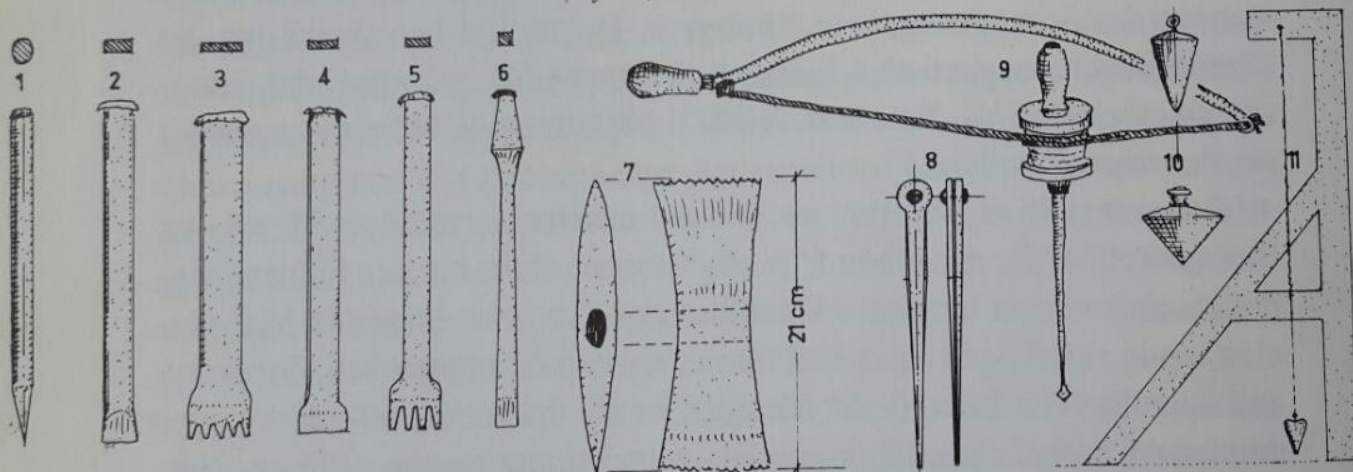



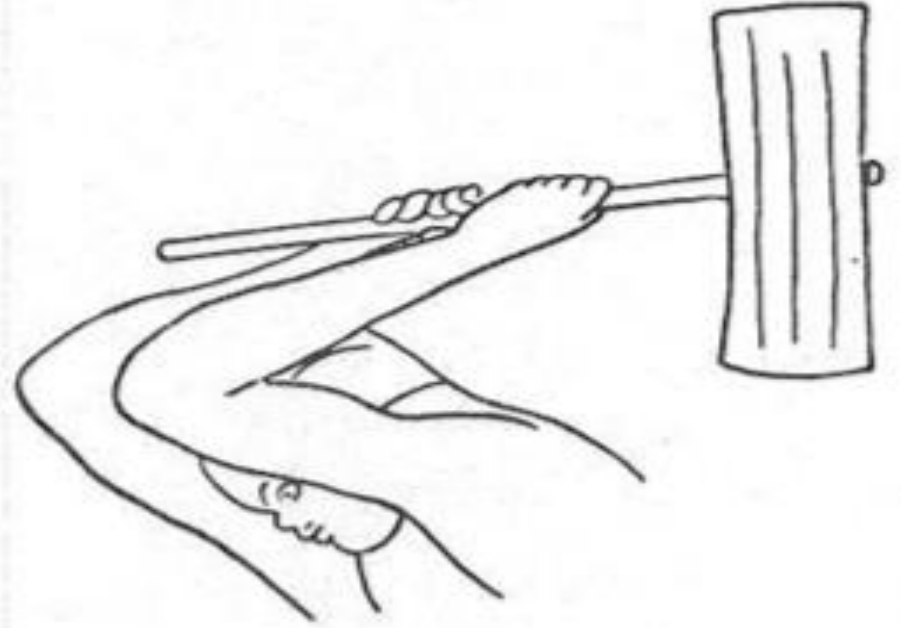
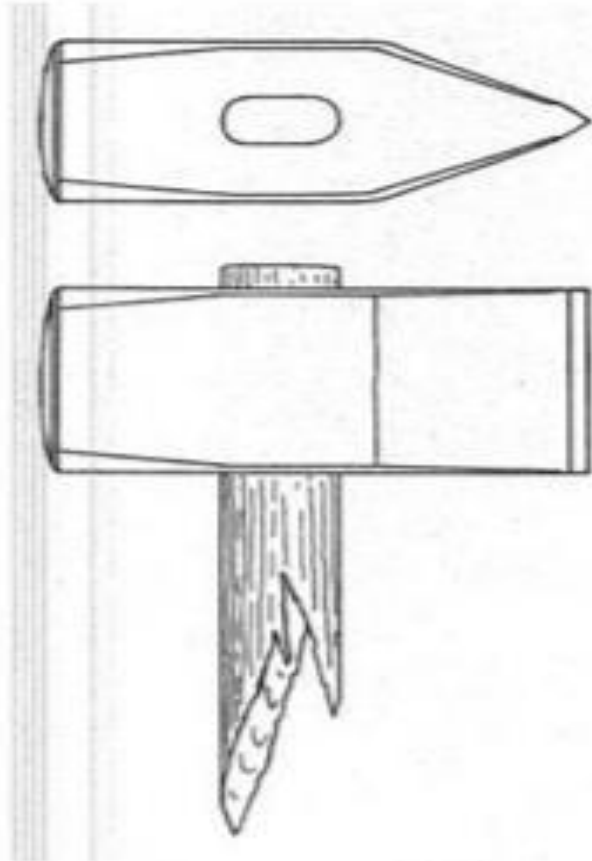

Resim 2. Balyoz (Varyoz), (Orlandos 1968, 45, Fig. 27, 29)

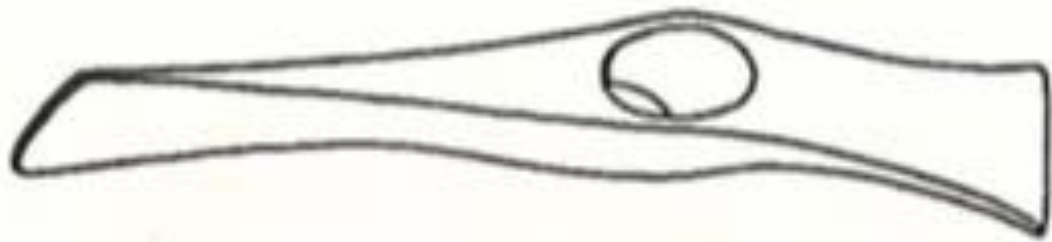

T

P



Res. 170a Boğazkale (Hattuşa) aşağı şehirde bulunmuş bir külünk ucu (Neve, Taf. 38/2).







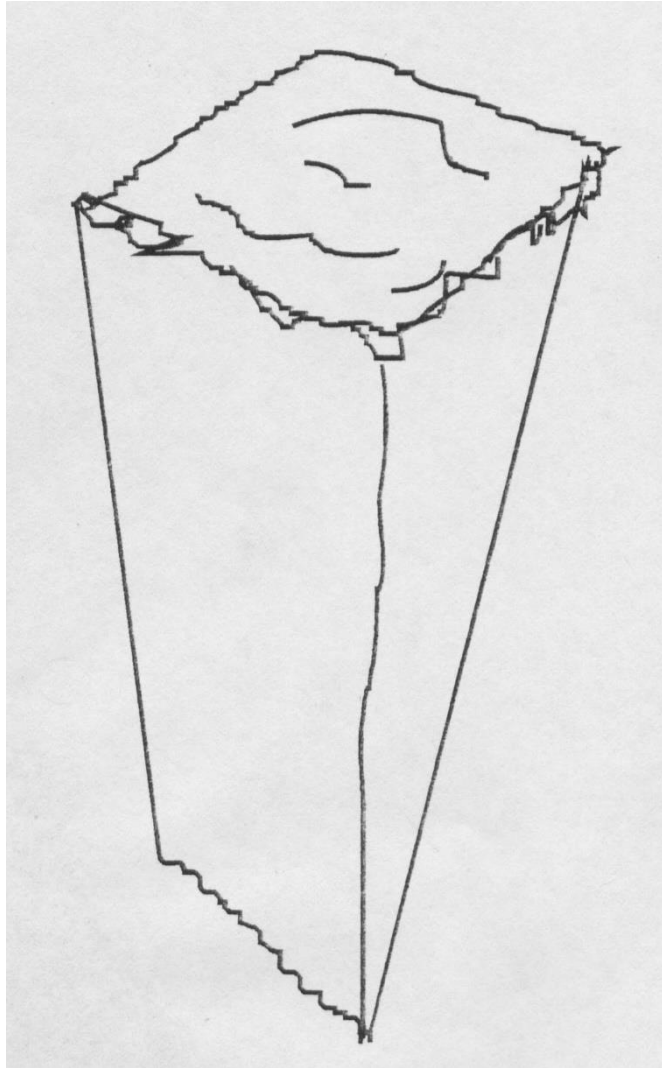

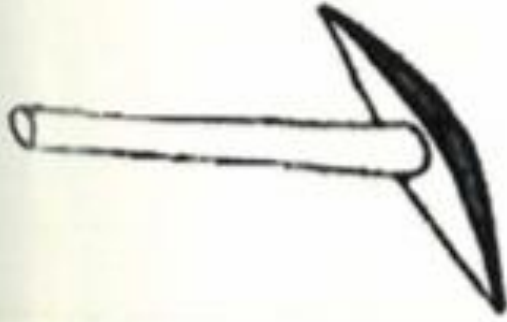

Külünk: Ağır, sert vuruş yapılabilen iki ucu sivri aletlerdir.



Madırğa (Taşçı Çekici):  
Murç, keski gibi aletleri çekiçlemek üzere kullanılan alettir.

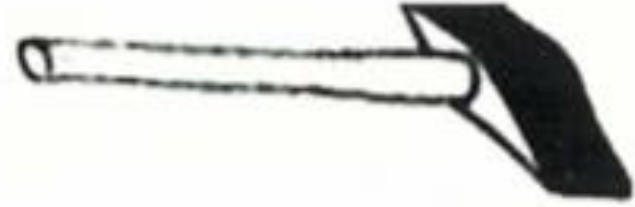

Taşçı Baltası: Ağır, sert vuruş yapılabilen, iki ucu sapa paralel, geniş bıçaklı genelde kesme ve küçük bloklarda şekil vermek için kullanılır.

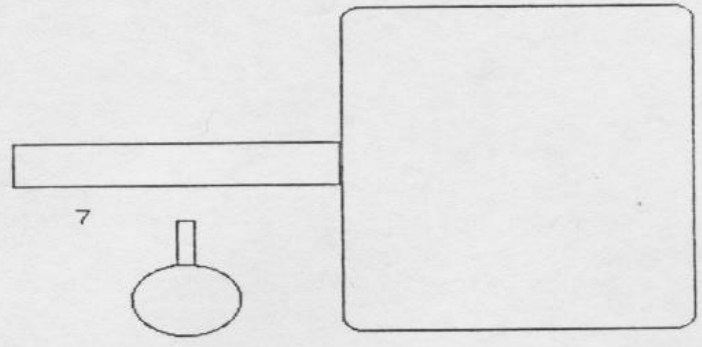
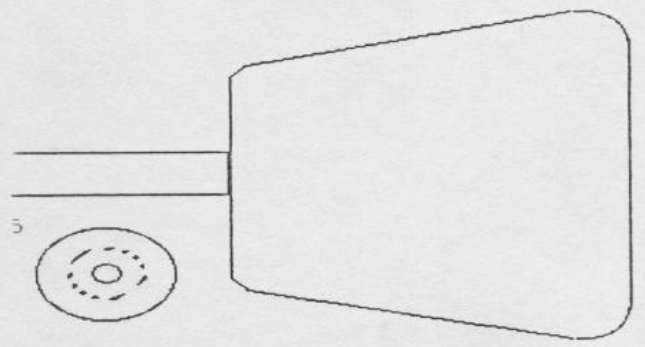
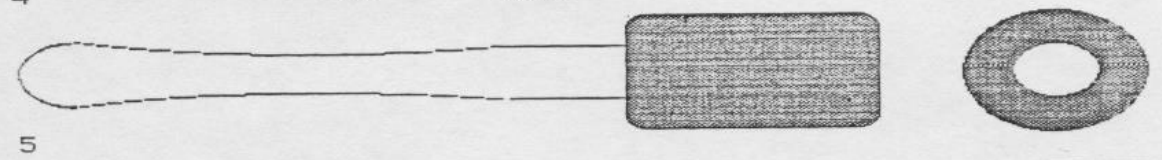
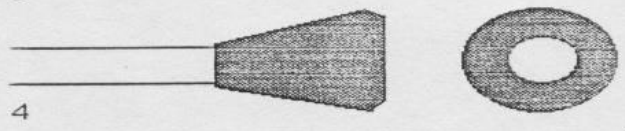
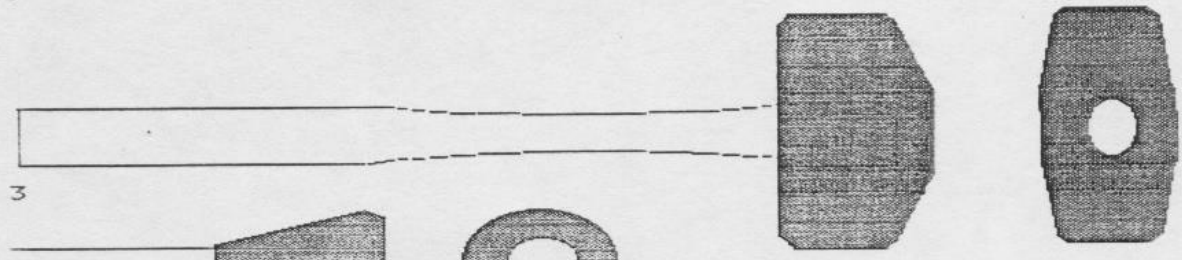
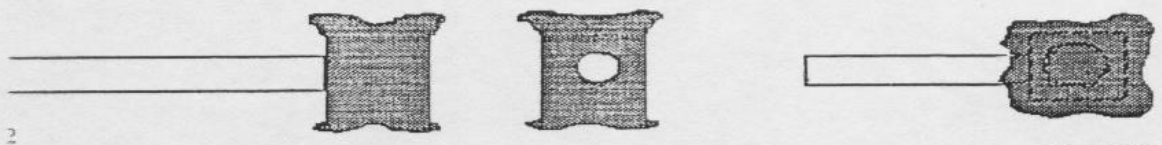
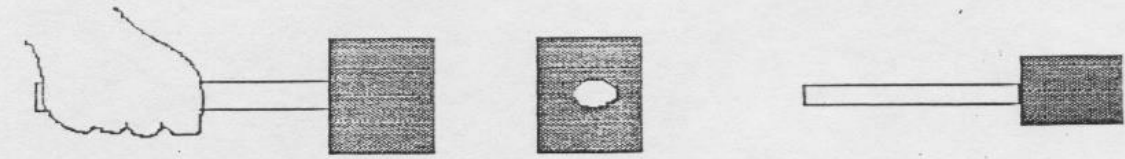

02271011







Murç ve madırğanın birlikte kullanımı, (Adam 1994, 34, Fig. 57).



Resim 8. Taşçı çekici, (Orlandos 1968, 45, 48, Fig. 30,36).

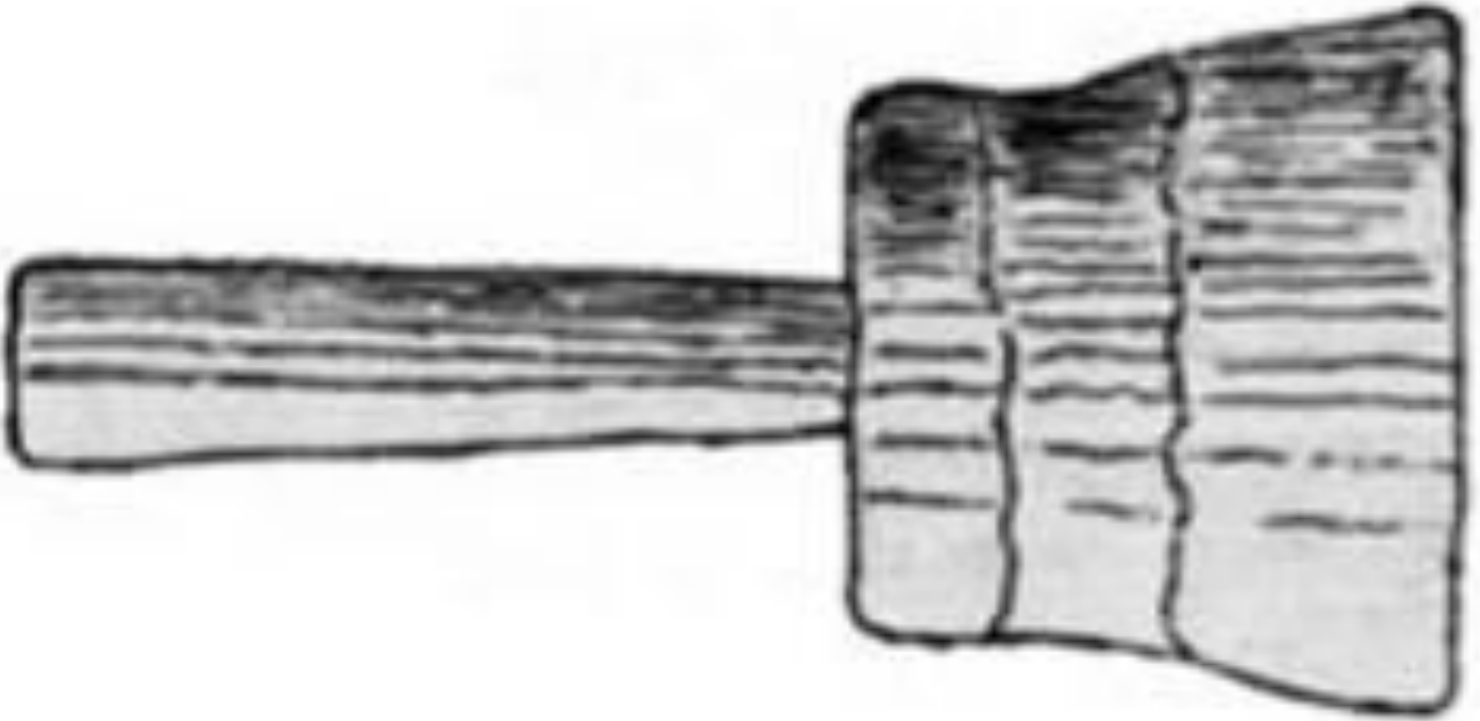

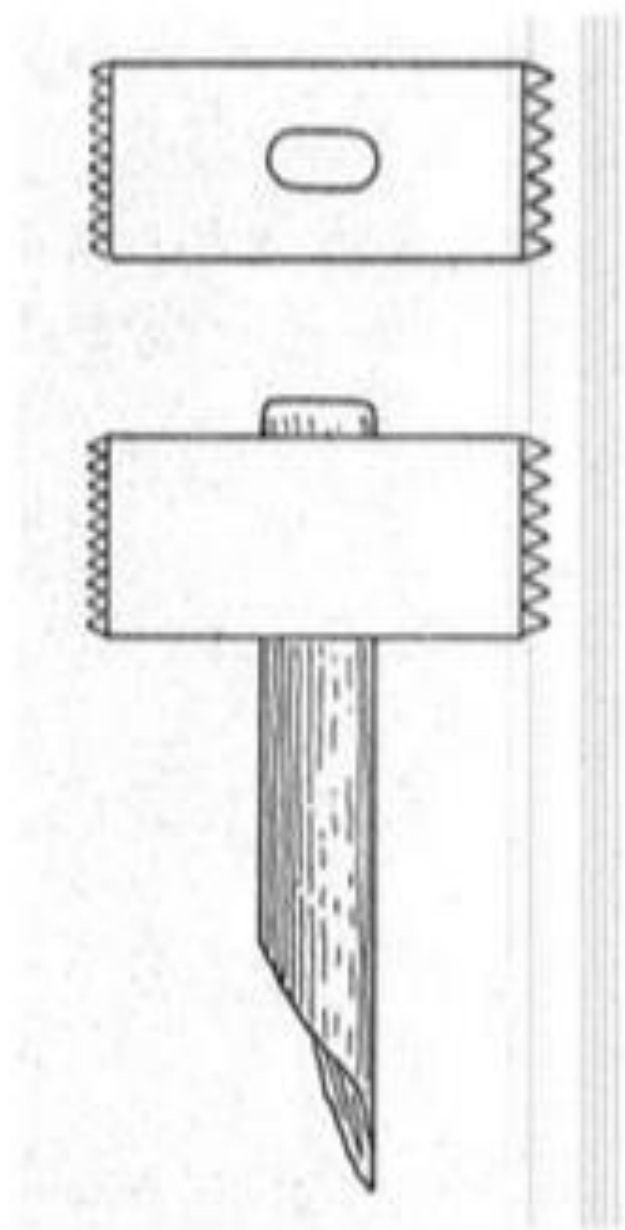

Resim 14. Mucarta, (Orlandos 1968, 48, 38).



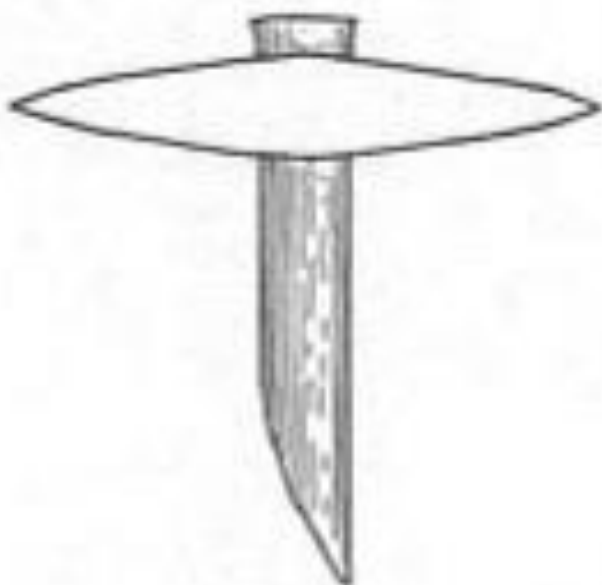
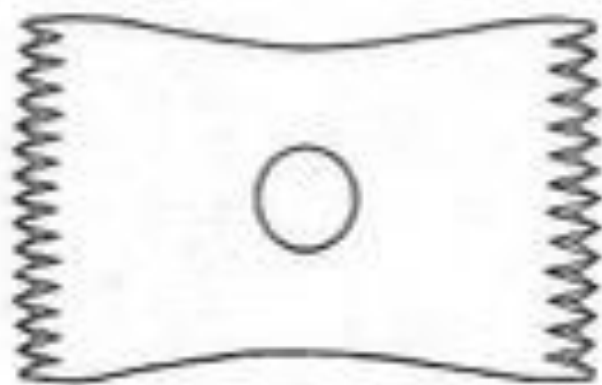

Resim 11. Modern taşçı tarağı,  
(Orlandos 1968, 52, Fig. 41).

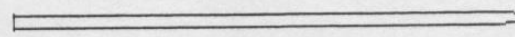
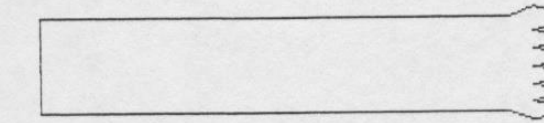
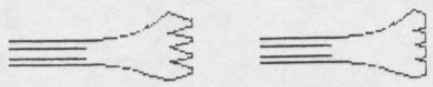
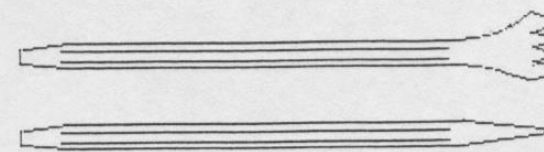
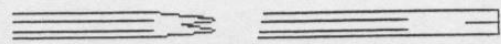
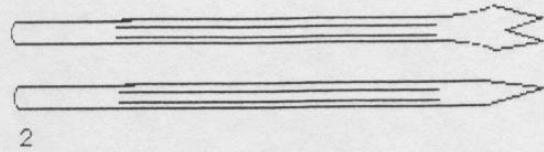
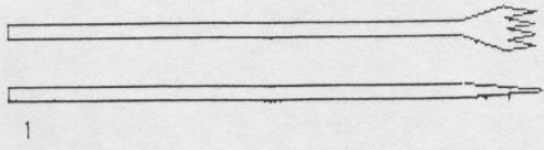

4

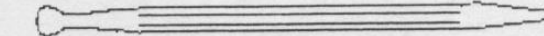

5

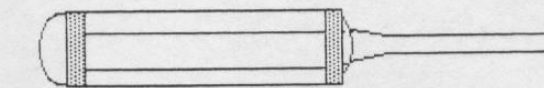
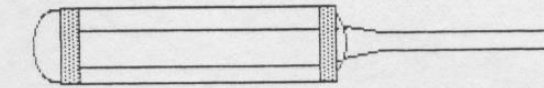

6

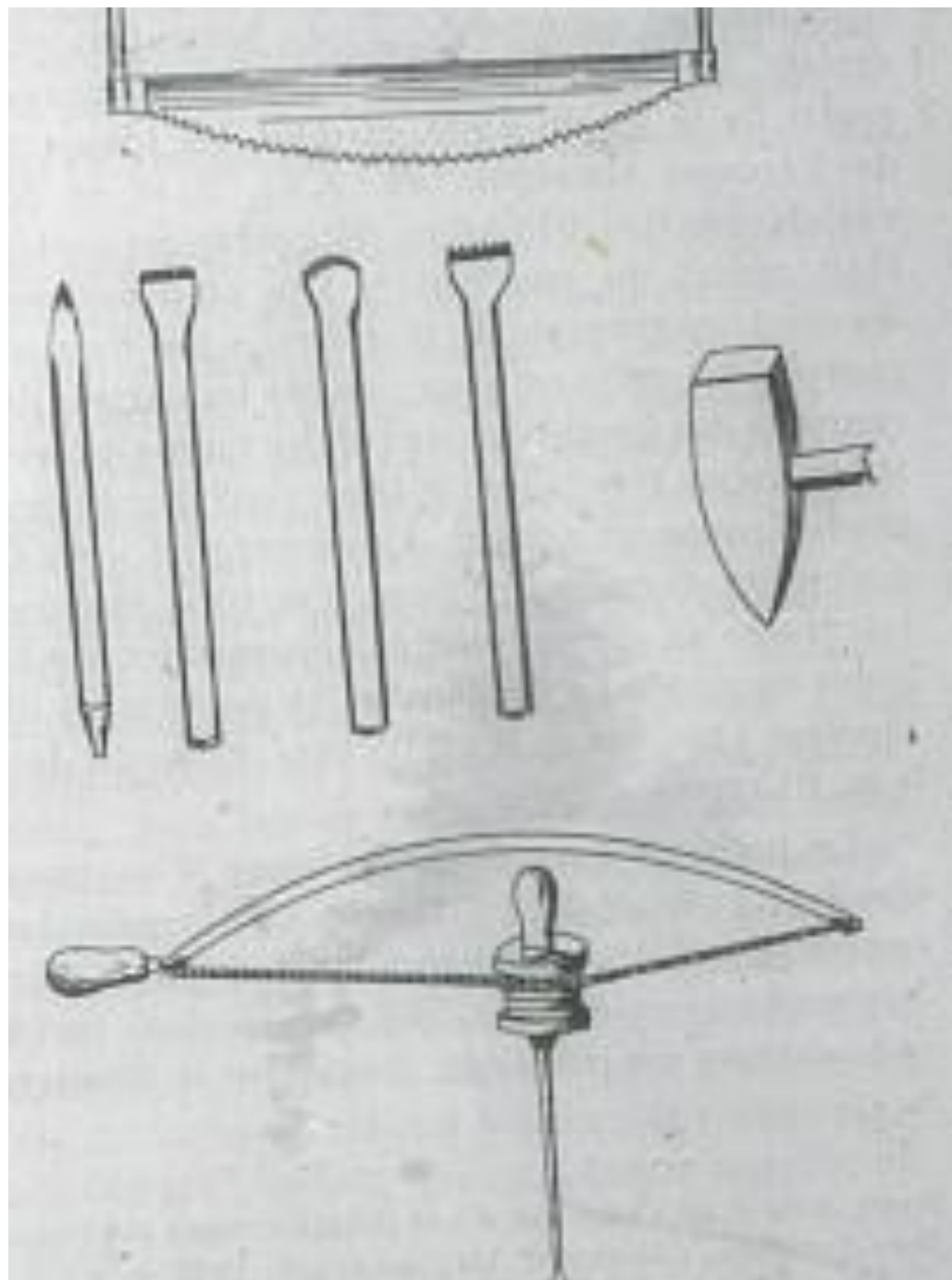

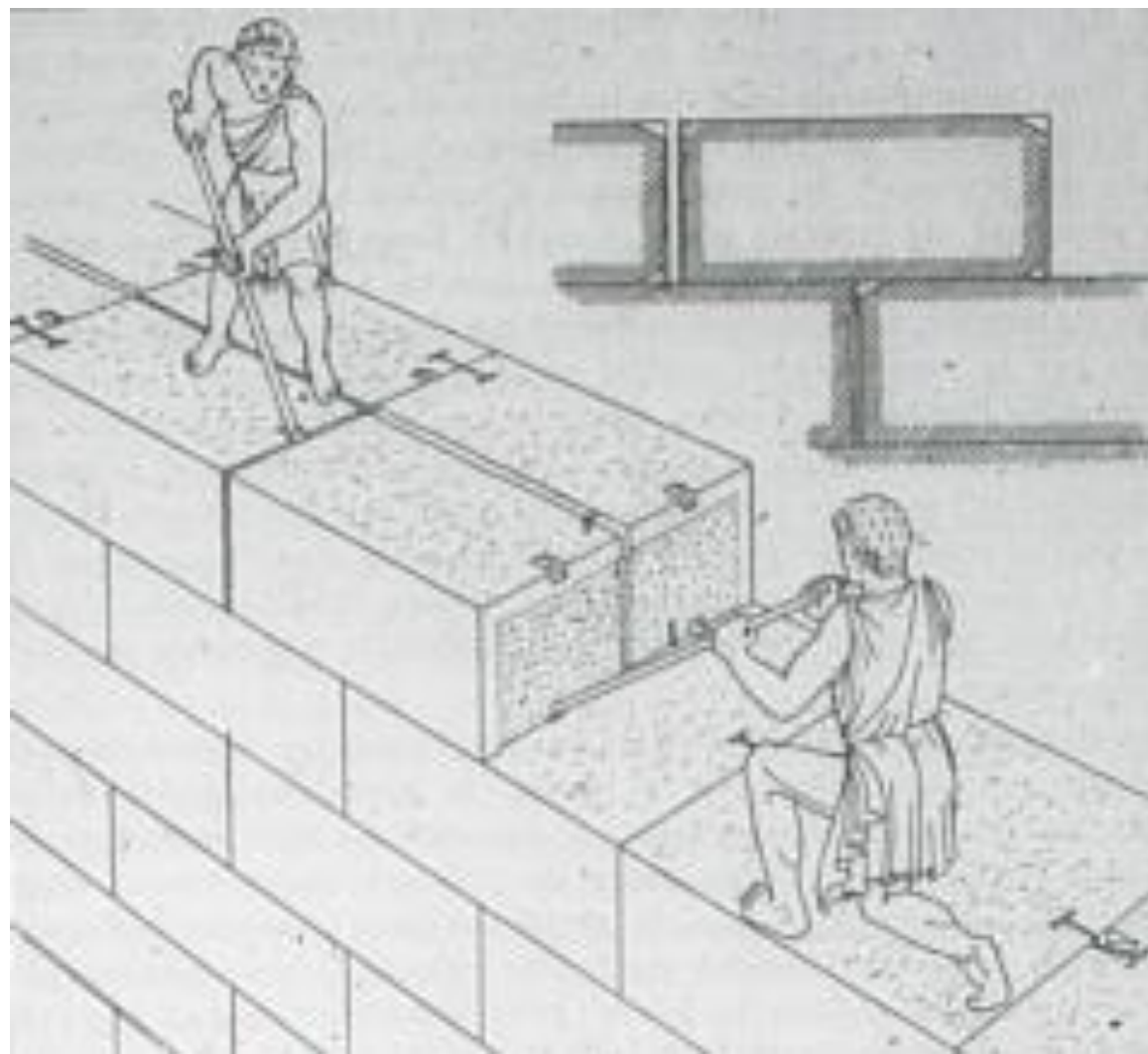

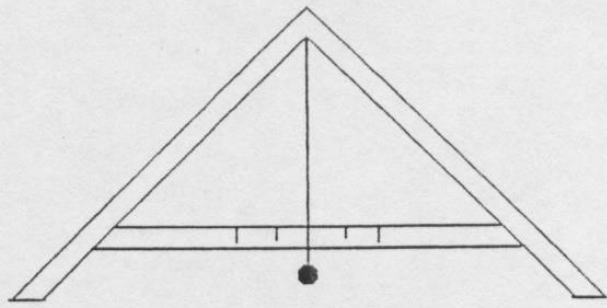

1

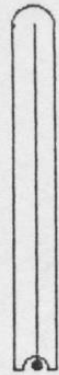

2

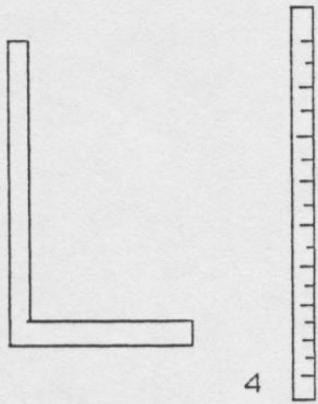

3

4

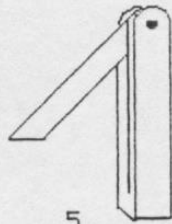

5

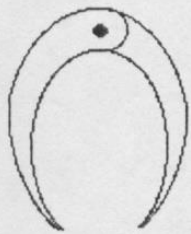

6



7



8



9

