

KLA 120
ANTİK MİMARİDE MALZEME - TEKNİK

6. Hafta

KLA 120

ANTİK MİMARİDE MALZEME - TEKNİK

**MİMARİ ELEMANLARIN
KALDIRILMASI**

Mimari blokların kaldırılması



106 Interior grips or self-adjusting lewis.

107 Grips (modern).

108 Holes for grips carved into a point, at the amphitheatre of El Djem.

109 Square holes for grips, theatre of Bullia Regia.

110 Summary of the different lifting methods in Roman architecture: bosses; grips; lewis.

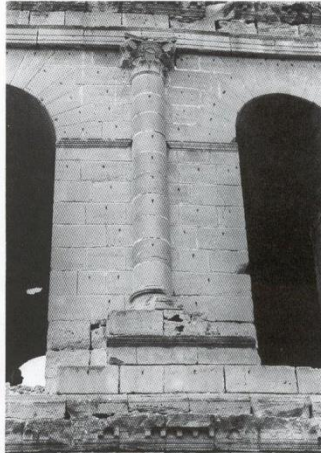

points of the self-adjusting pincers grip in small holes made symmetrically in the two vertical surfaces. When the grips are used on the joining surfaces (the pediment monument at Glanum, for instance), the process remains invisible and so is superior to the use of the lewis as it is much quicker. However, when the holes are cut into the front and back faces of a block, the numerous marks are visible on the facing (Porta Maggiore, amphitheatre of El Djem, theatre at Bulla Regia).

The use of grips, even though well

require an exact size of hole to be cut (fig.106).

With the use of grips or iron forceps (*ferrei forfices*) the preparatory work is even further reduced; all that is necessary is to make sure that the two hooked

110

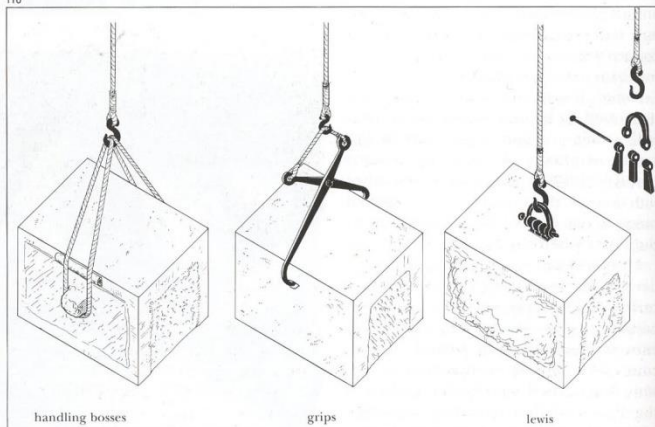

handling bosses

grips

lewis

92

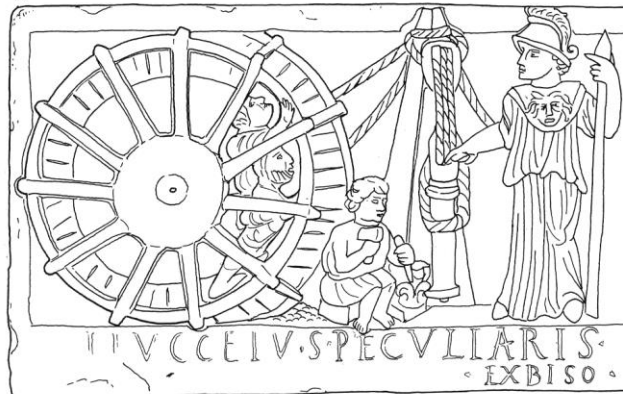

92 A lifting machine shown on a relief found at Capua. The motor wheel, operated by two workmen, is shown as independent from the crane, which is lifting a monolithic column into place using a block and tackle. The workman in the front is carving a capital.

93 Reconstruction of the machine shown in the Capuan relief, fig.92.

94 A lifting machine of great power, with a motor wheel worked by five men, from the funerary relief of the family Haterii, in the reign of Domitian. (Lateran Collections, Vatican Museum.)

95 Reconstruction of the machine shown in the relief of the Haterii, fig.94.

94

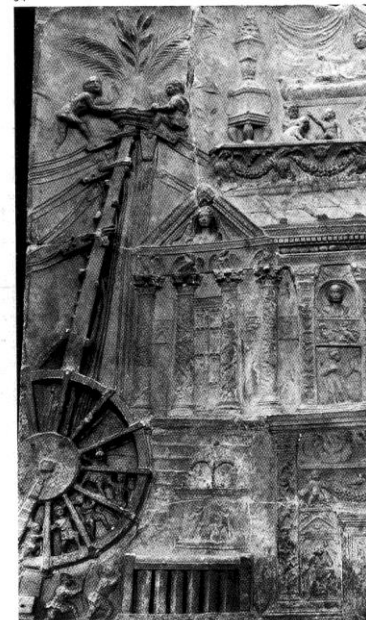

93

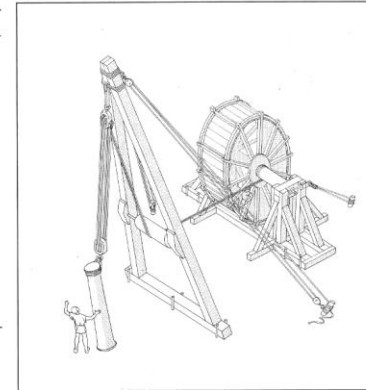

95

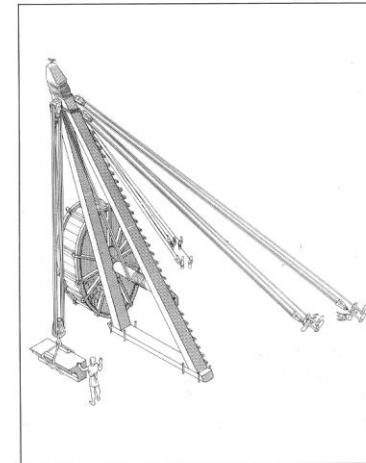

clearly visible on the relief on the tomb of the Haterii⁶³ where an enormous machine is shown with no fewer than 7 leg supports, 5 at the back, 2 at the front, all with pulley blocks.

This machine, with the hollow drum

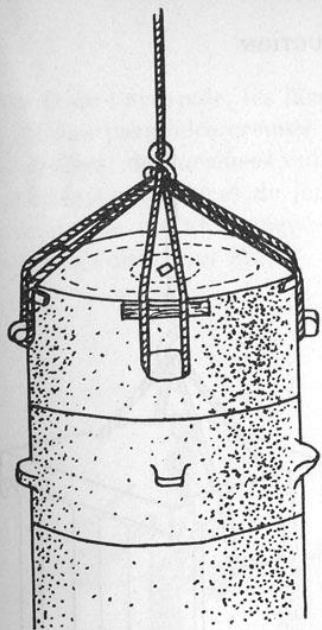

Fig. 86. — Bardage du tambour avec tenons.

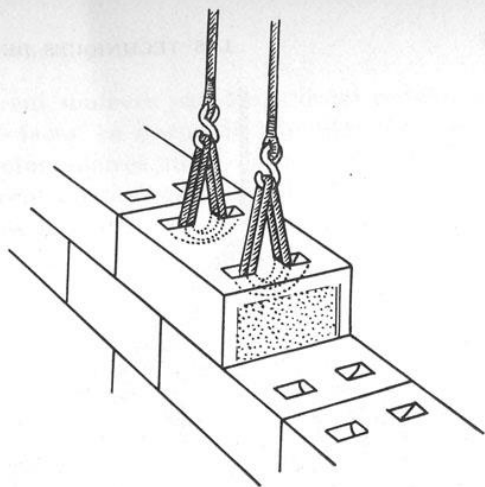

Fig. 88. — Bardage avec double canal en V.

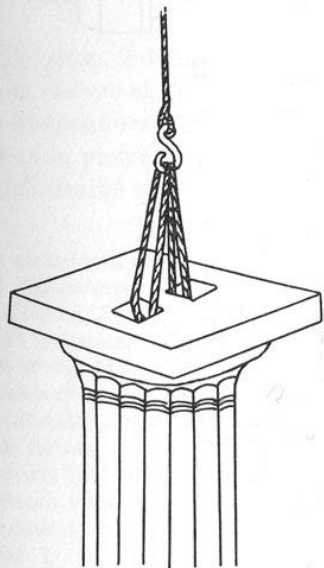
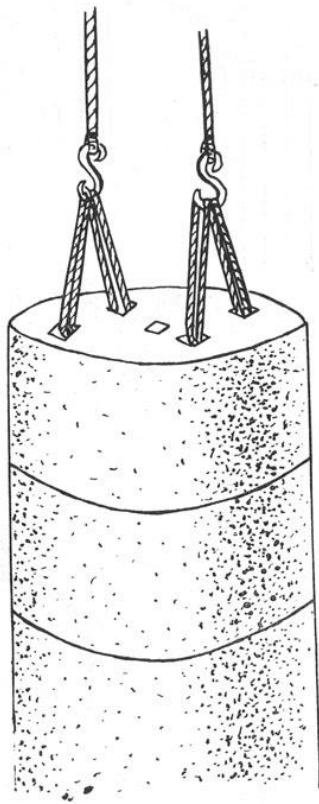
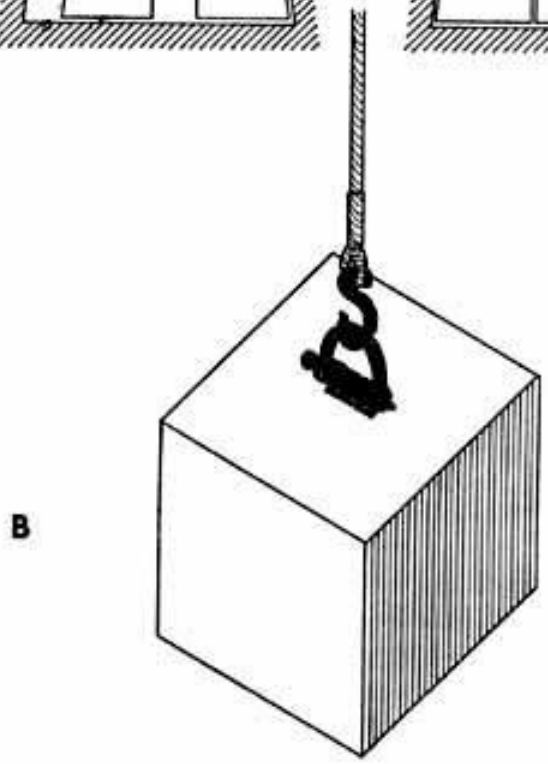
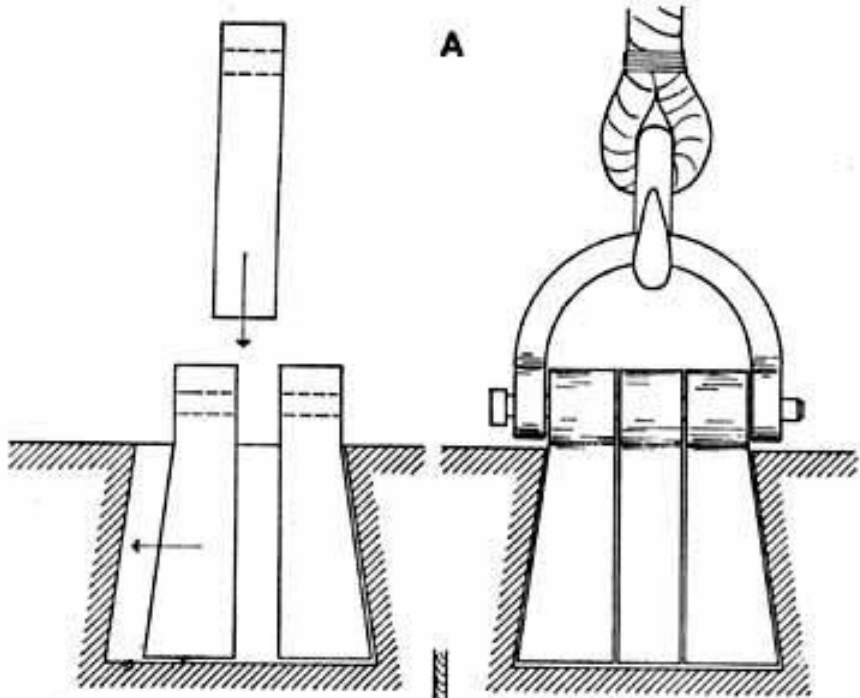
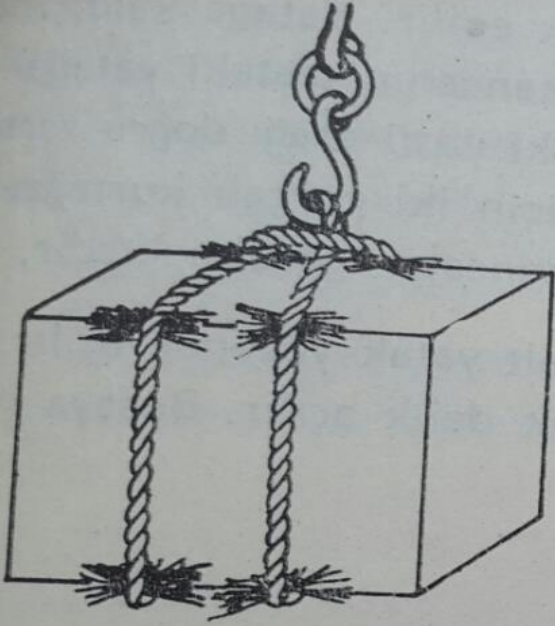

Fig. 87. — Bardage avec canaux en V.







Şekil : 71

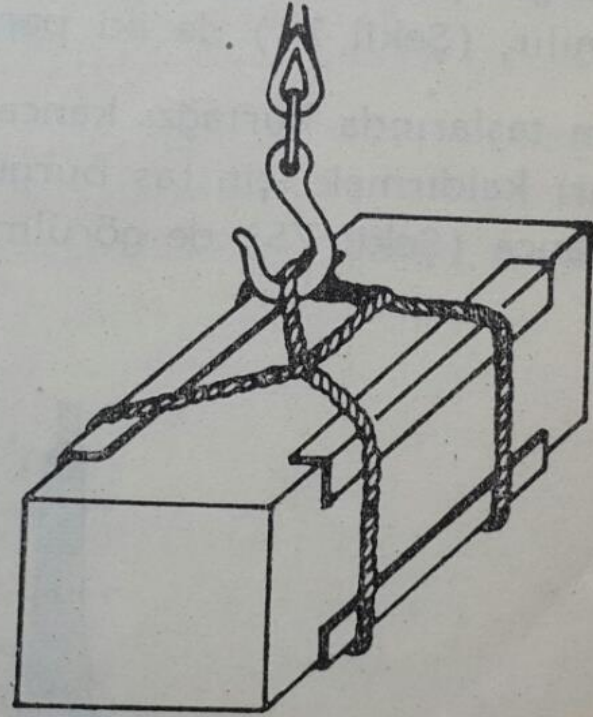

Şekil : 72

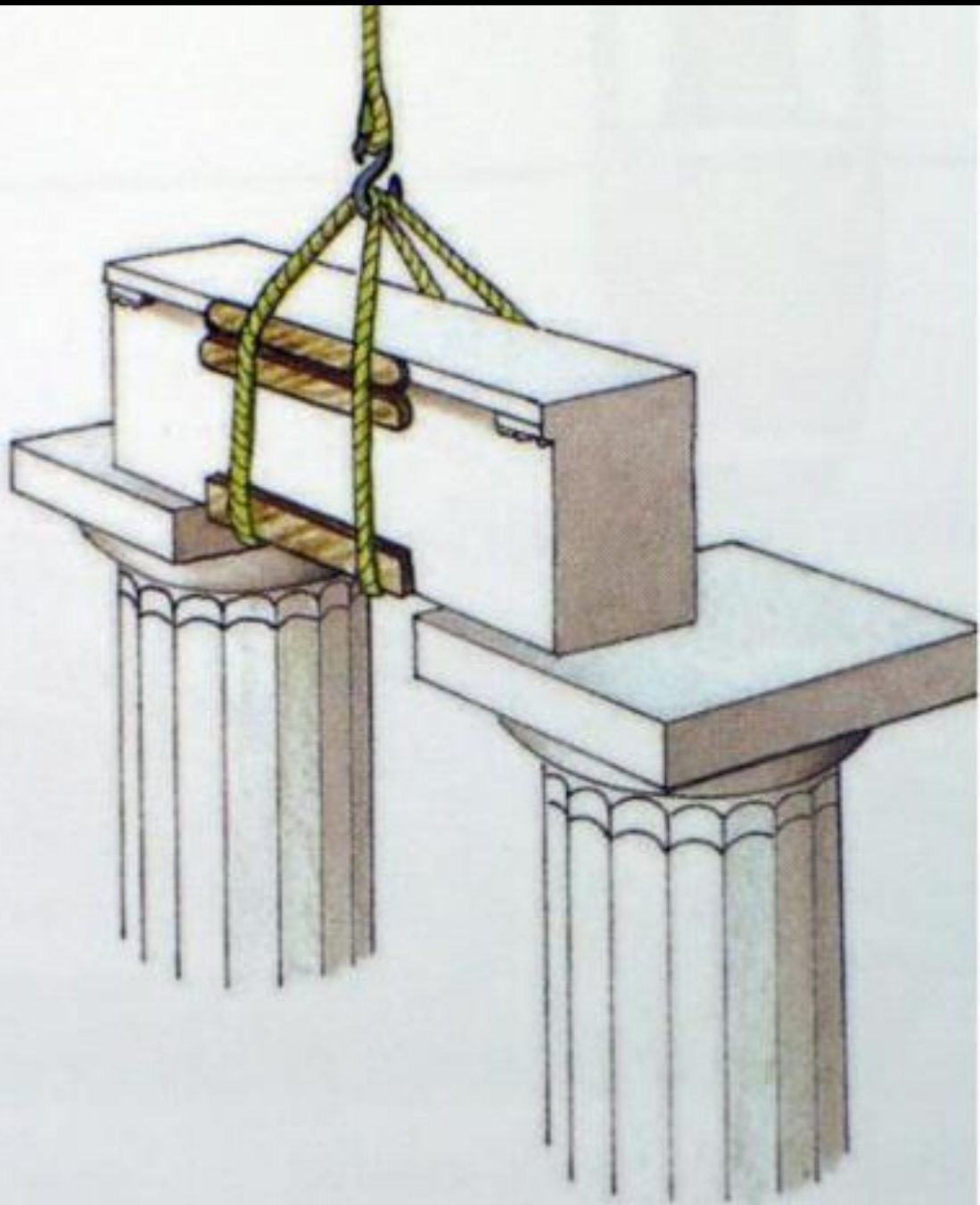





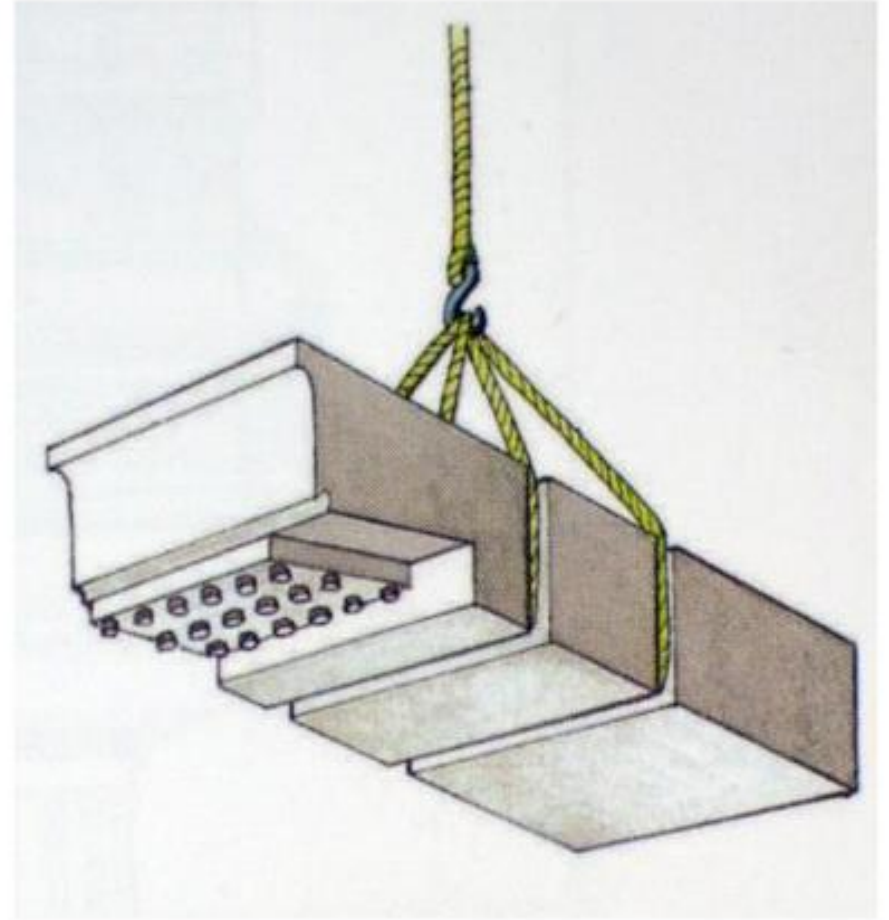
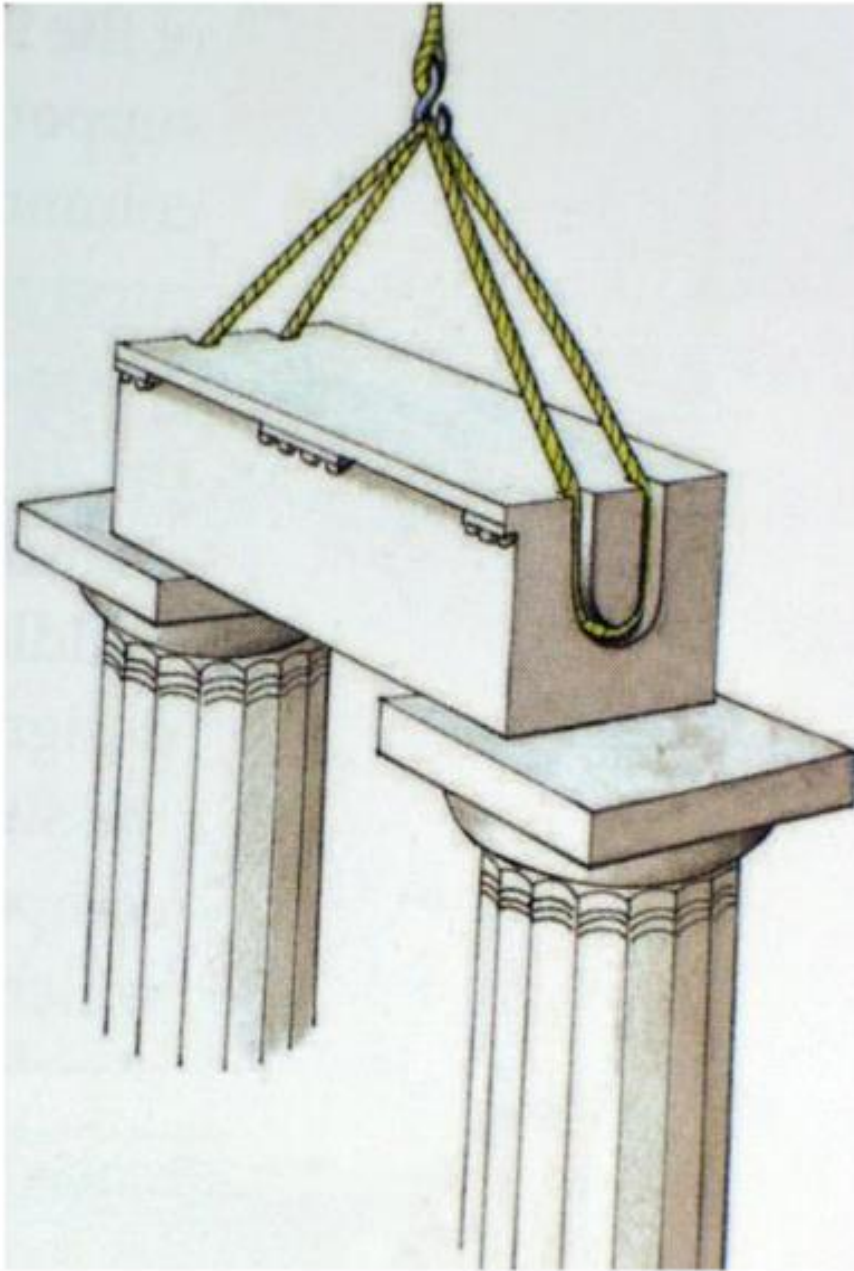

Resim 6. Halatı taşın üzerine açılmış kanallardan yapılmış kaldırma, (Durando2002, 85).

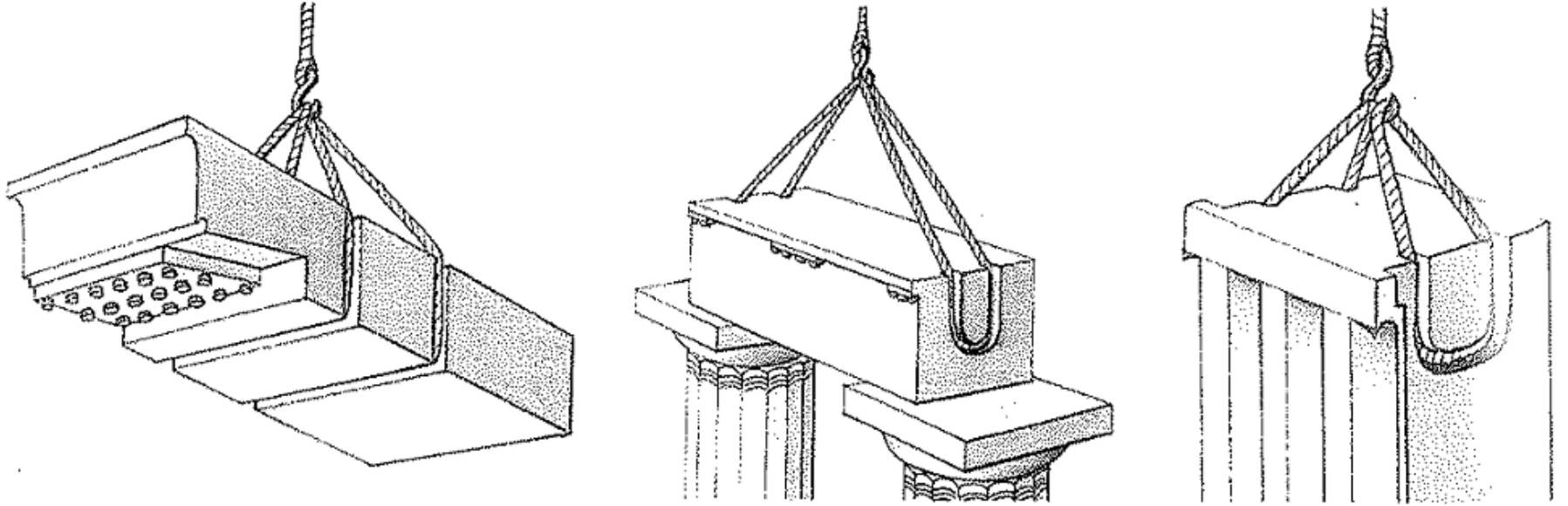

Res. 81. Yan ve alt oluk (A) ile yan U oluk (B, C) sistemleri.

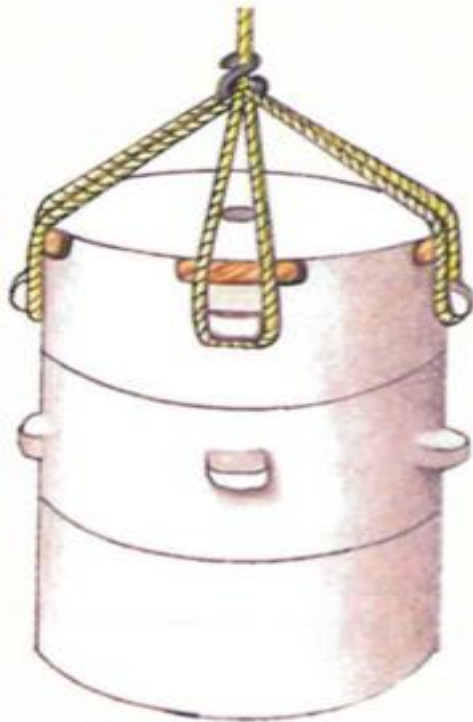
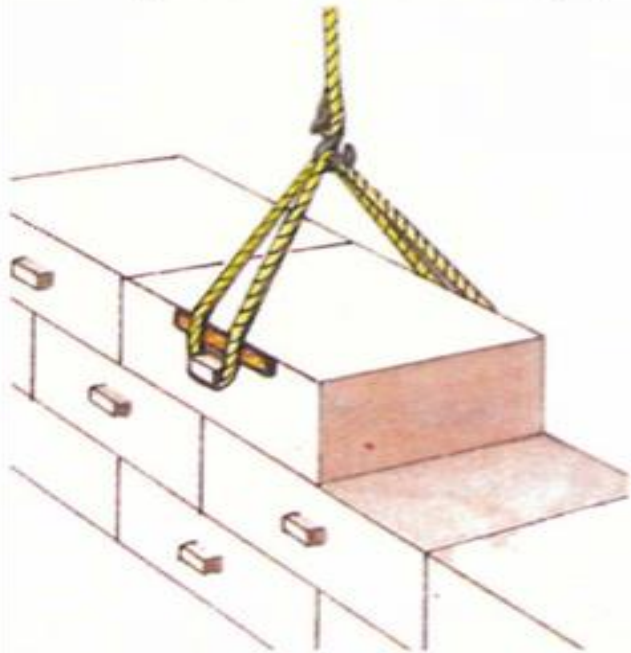





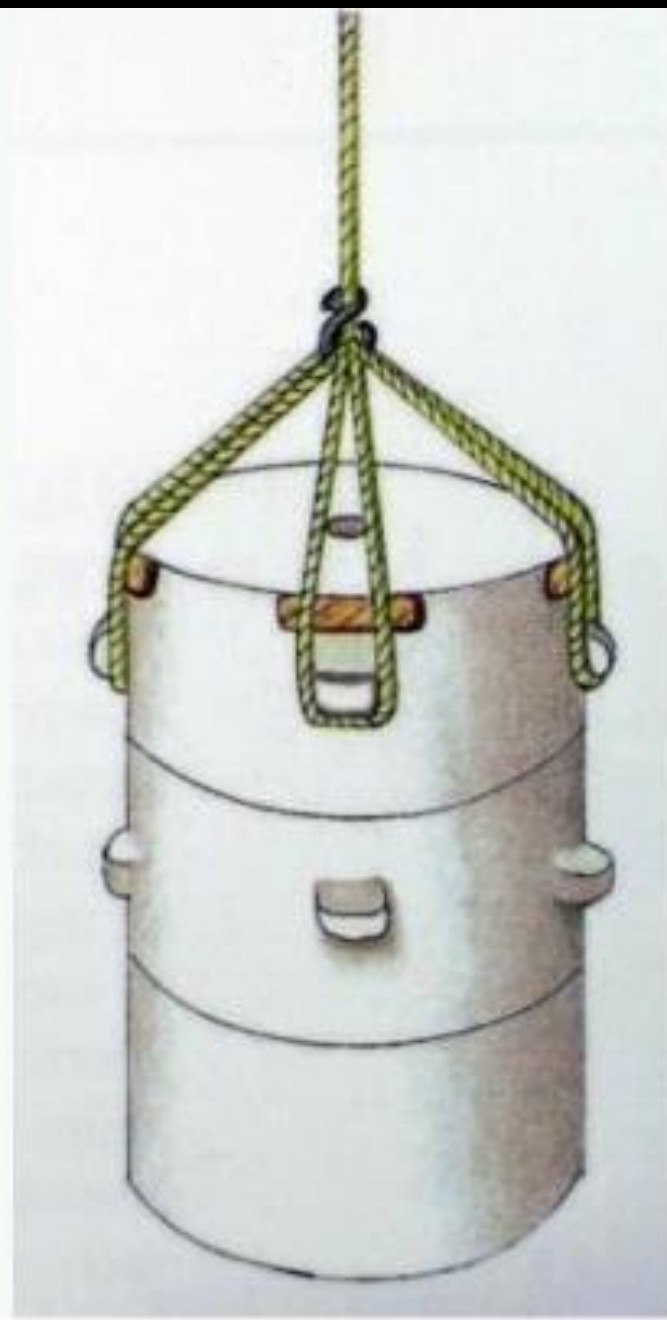
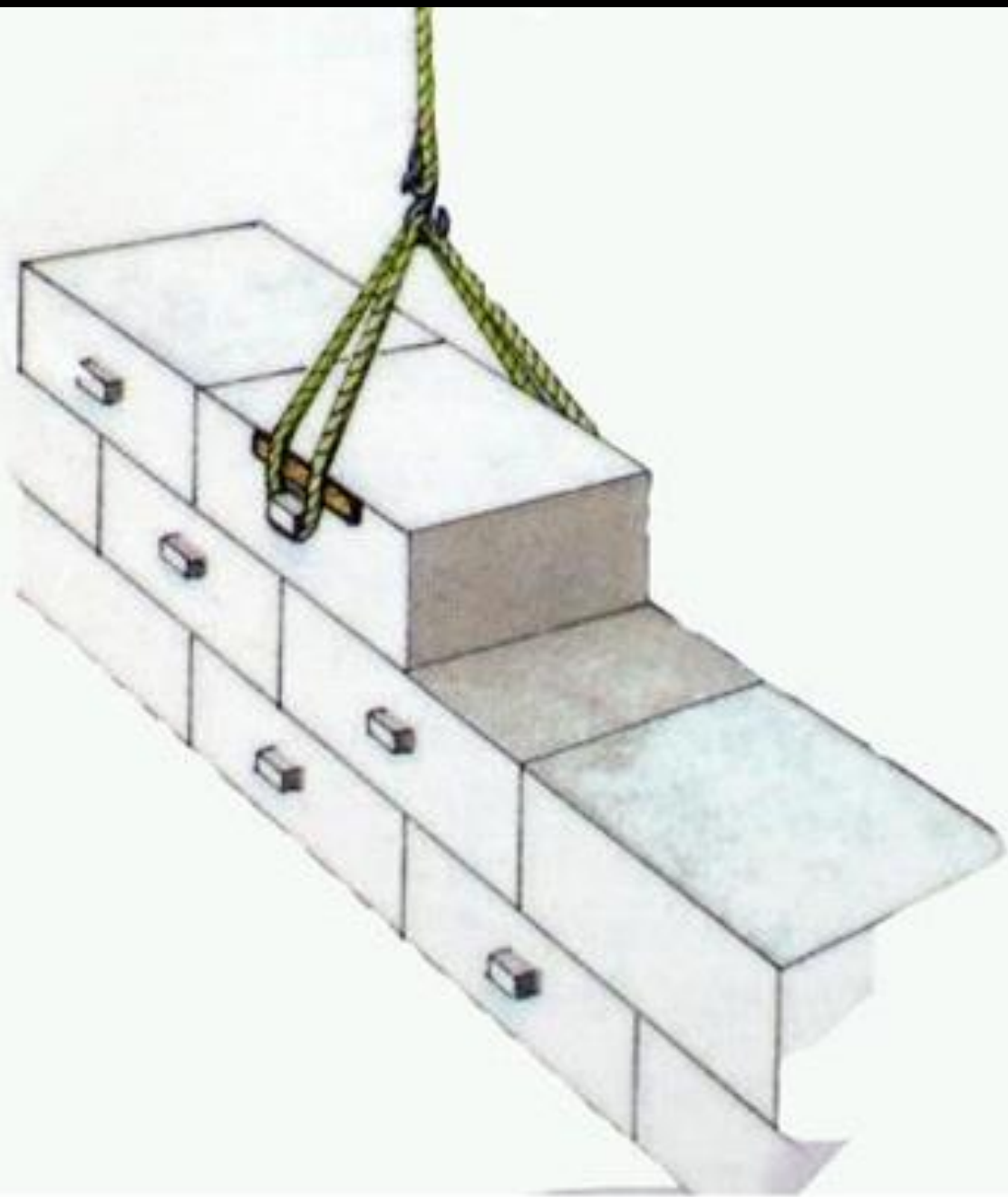

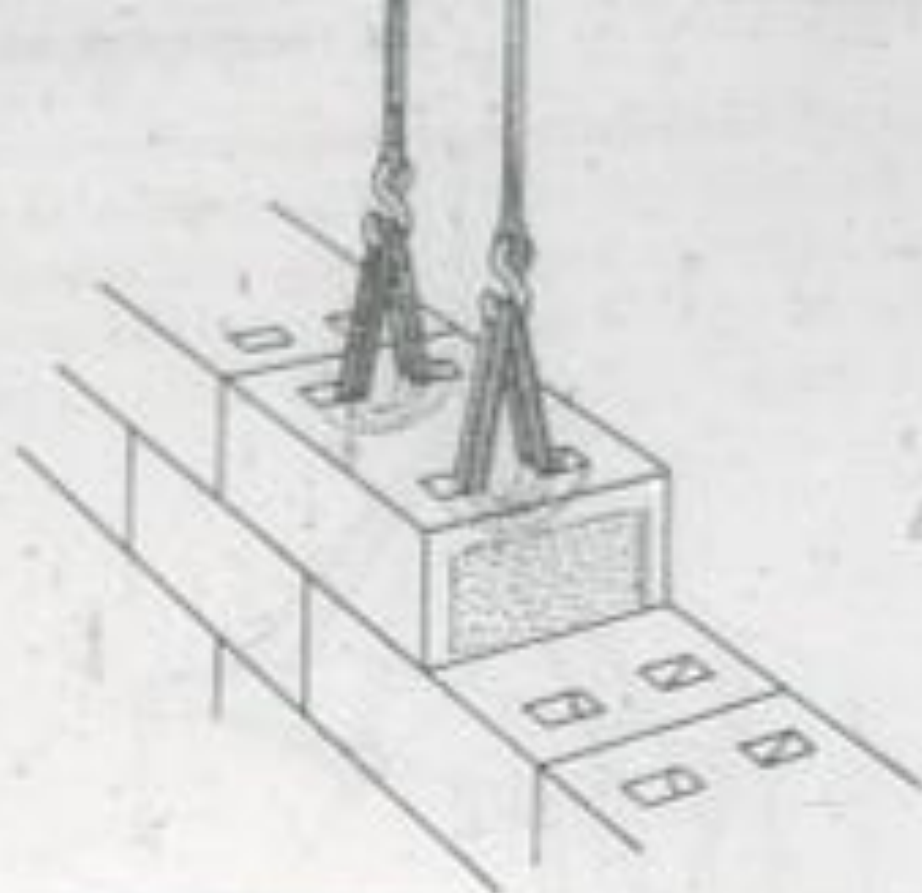
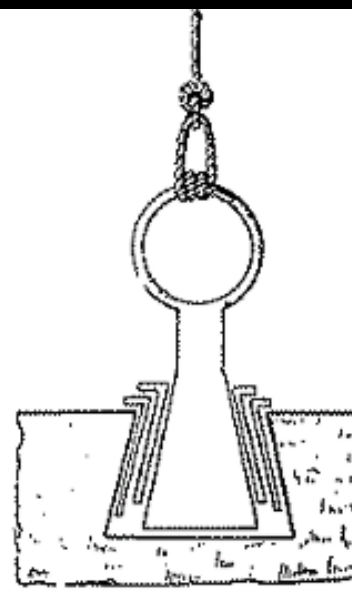
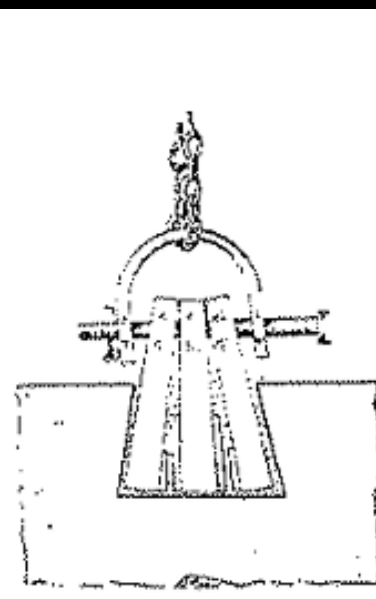
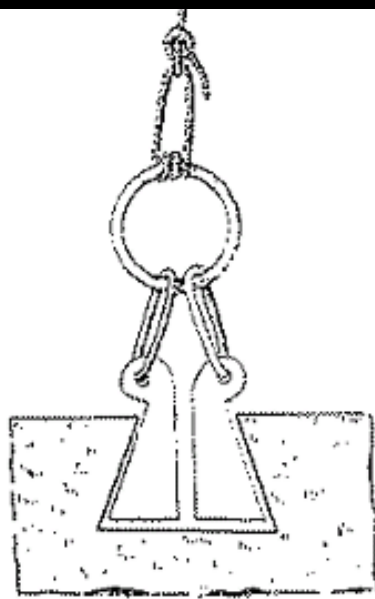
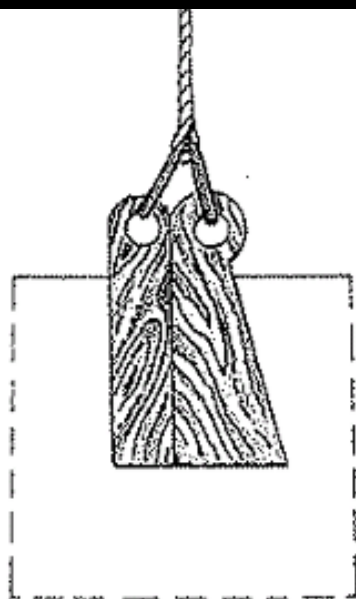
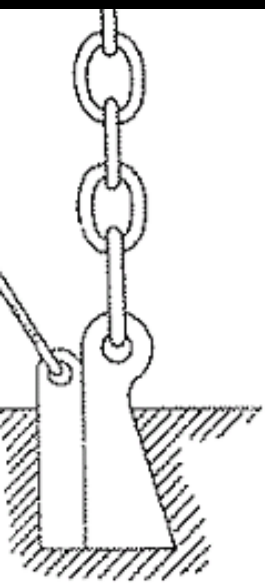
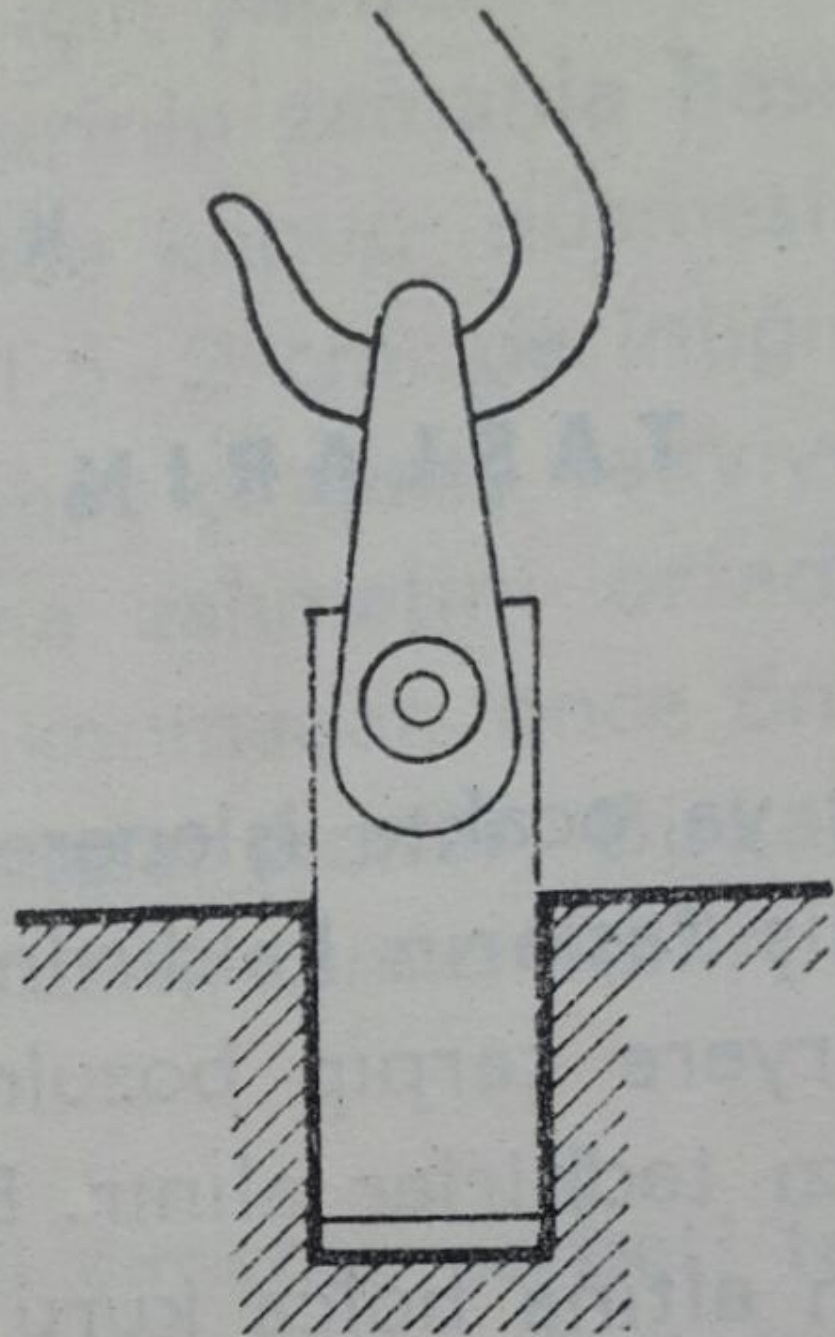
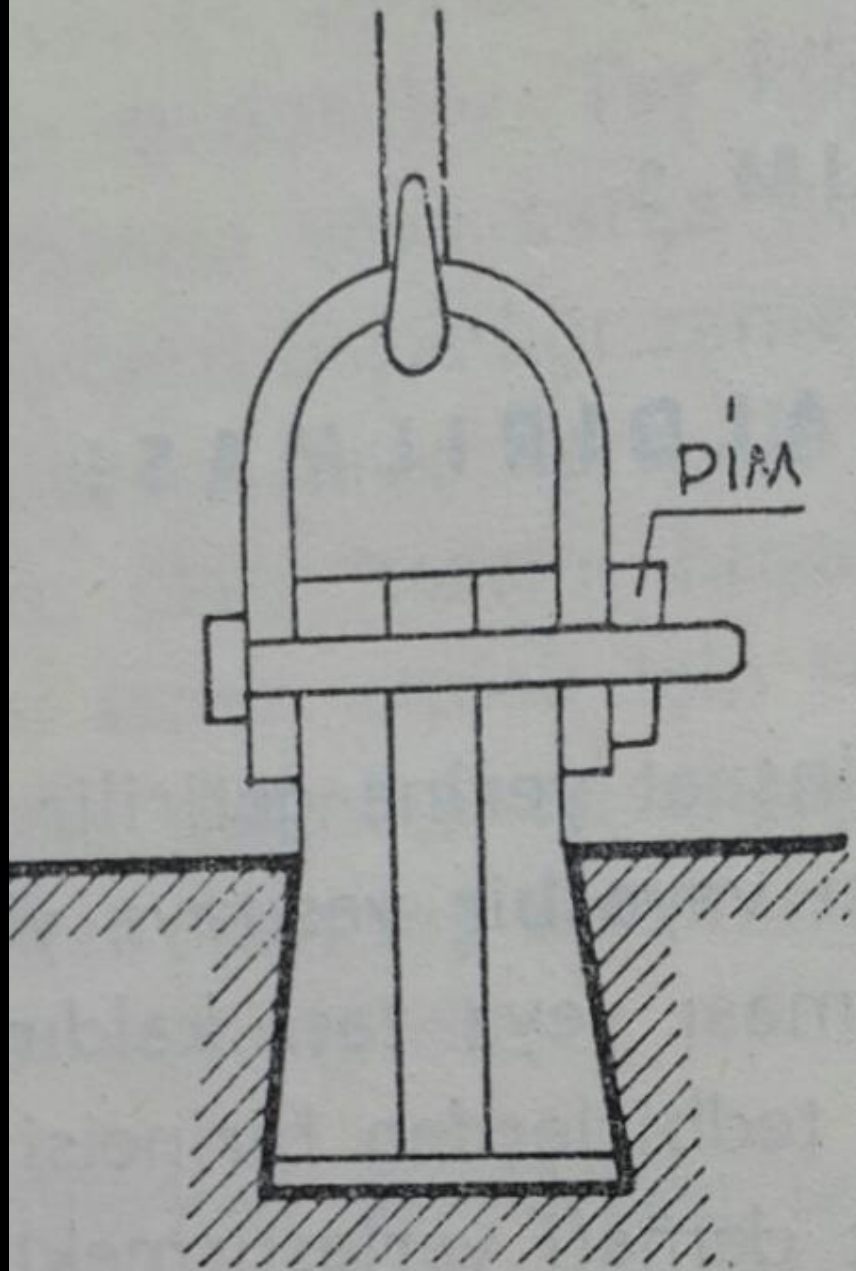
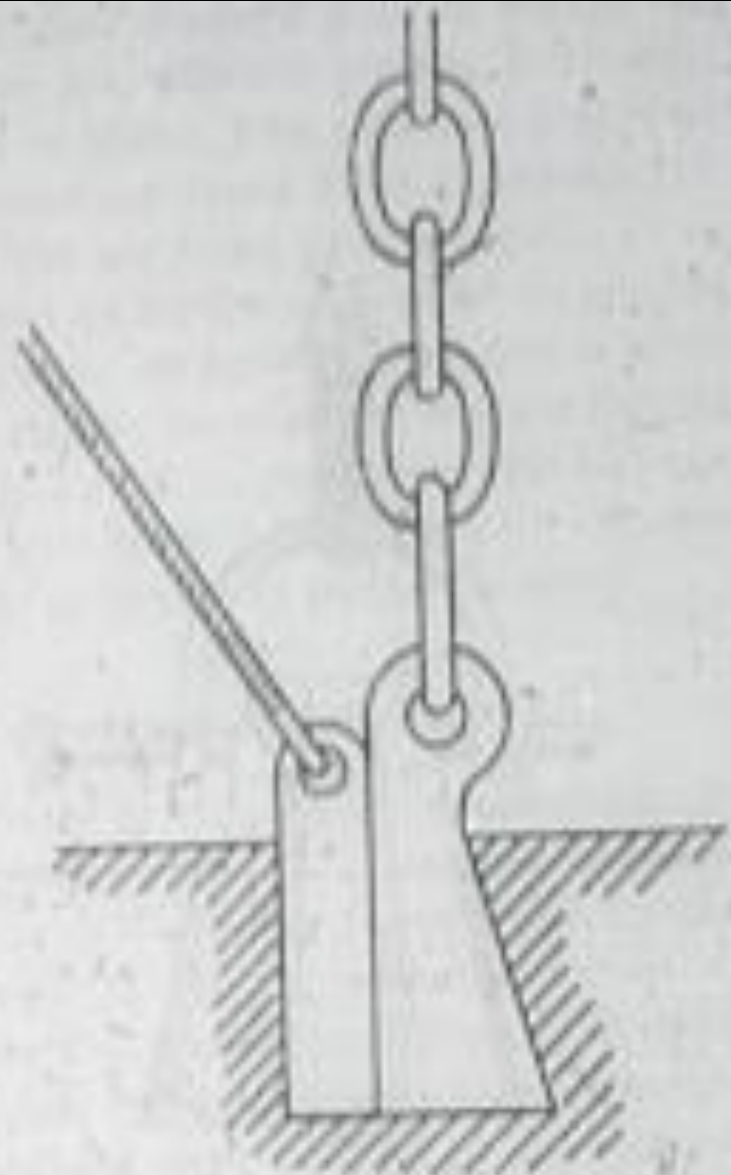
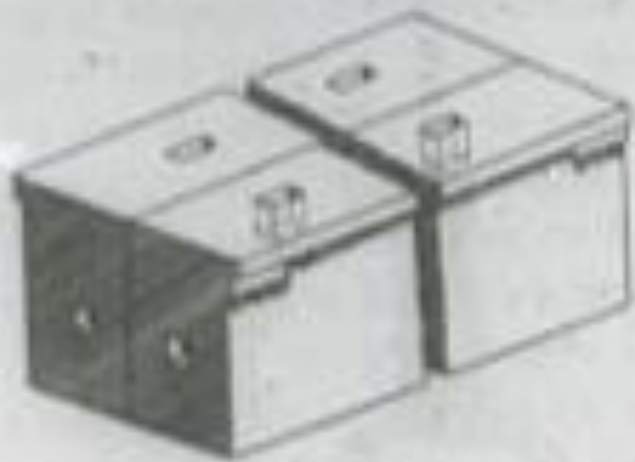
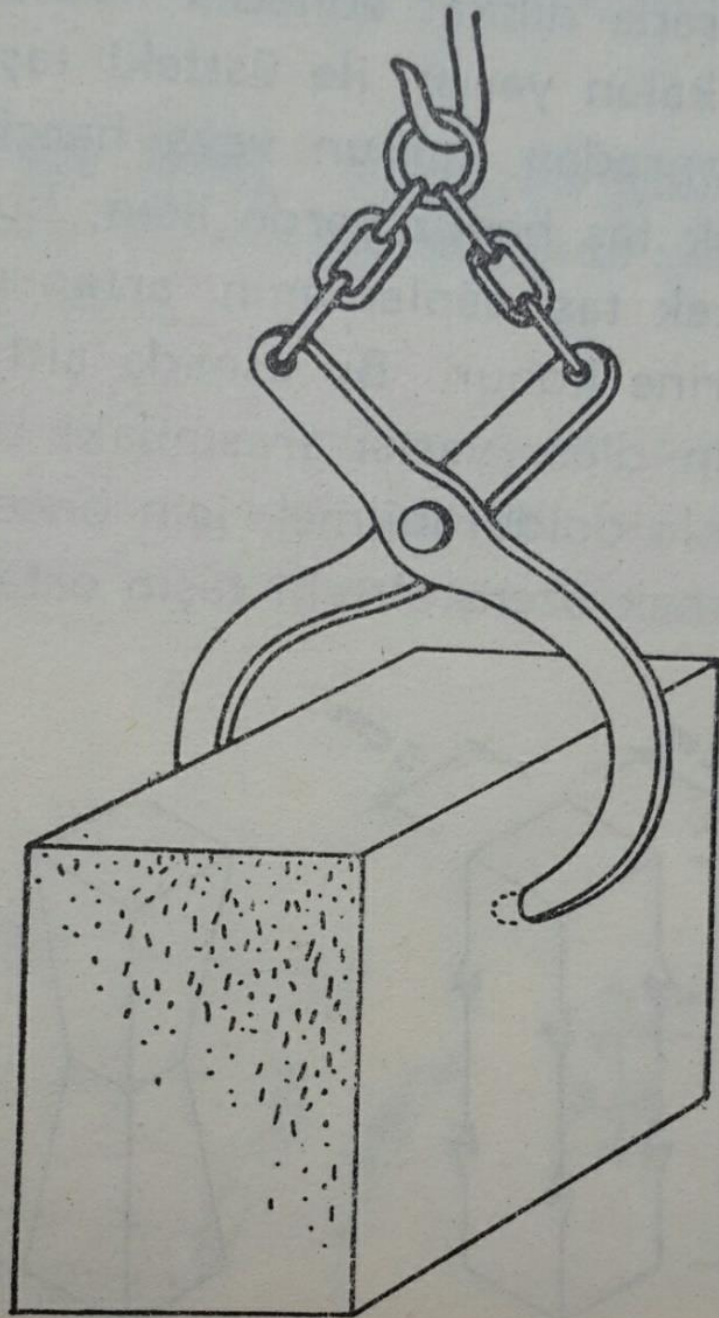

Fig. 86. — Harlage du tambour avec treuils.









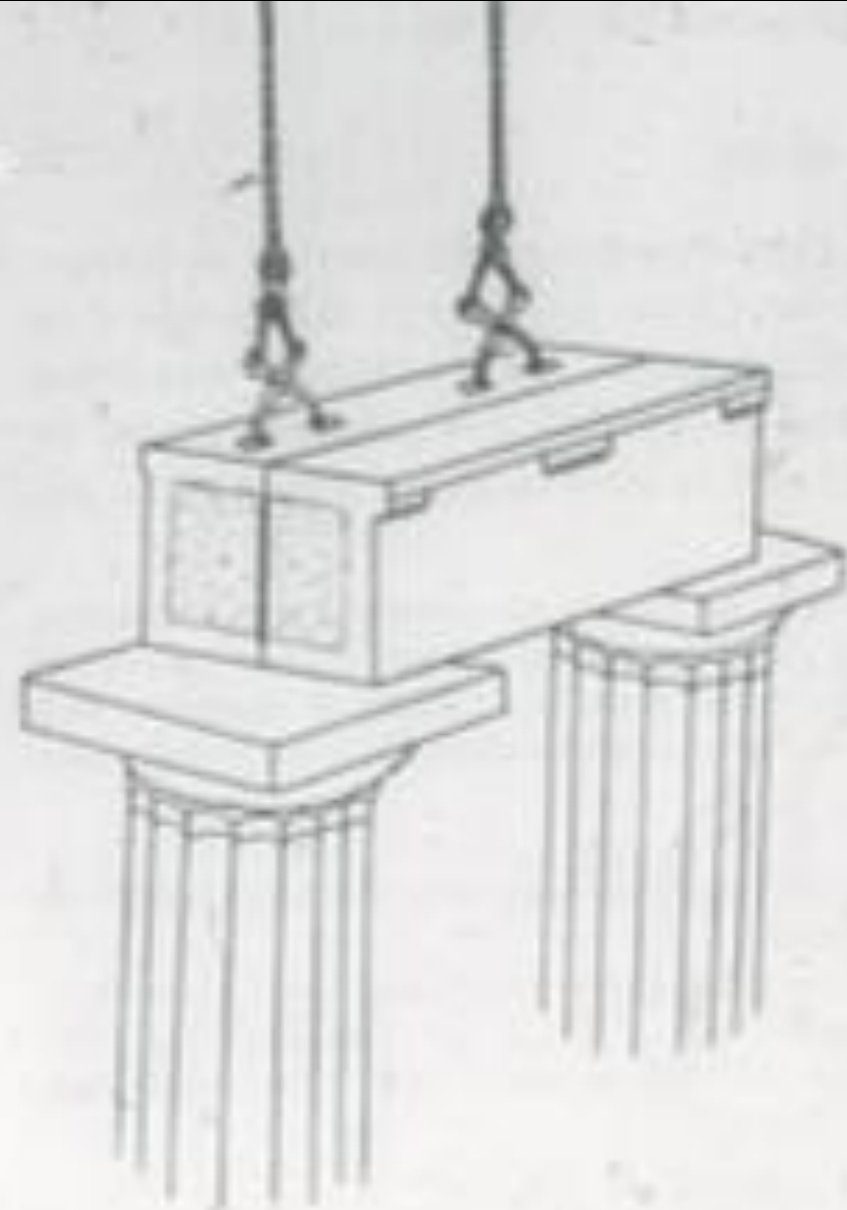
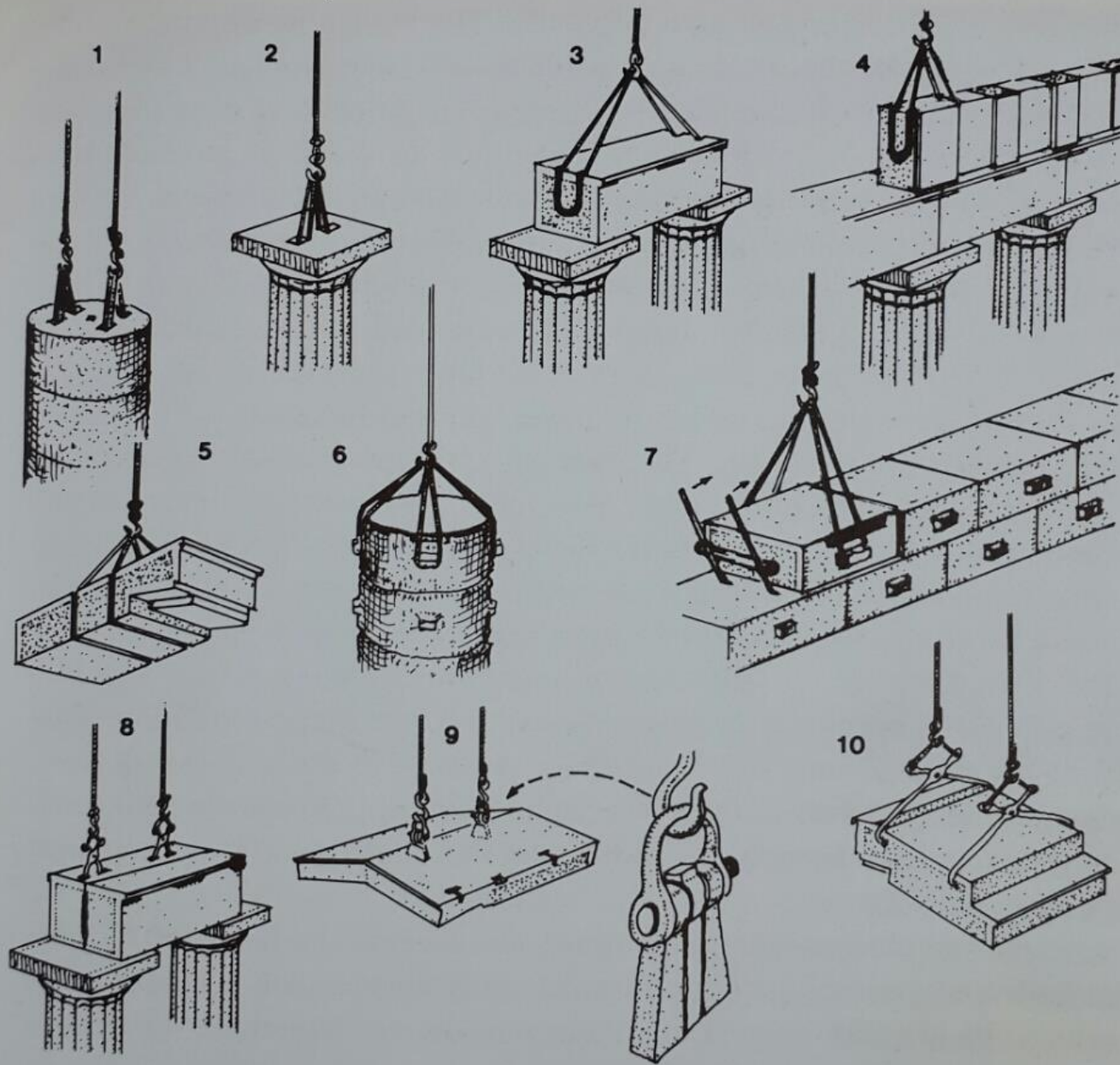

Fig. 85. — Levage avec double pince.



Fig. 86. — Mise en place avec pince (Erechtheion).





39 Antike Hebetechniken: 1-2: Hebelöcher im Werkstück; 3-5: Heben mit Seilnuten; 6-7: Heben mit Hebebossen; 8: Hebezangen; 9: Heben mit dem sog. Wolf; 10: Hebezange