

Chapter 7: Electronics related to nuclear medicine imaging devices

Slide set of 60 slides based on the chapter authored by
R.J. OTT and R. STEPHENSON
of the IAEA publication (ISBN 78-92-0-143810-2):
*Nuclear Medicine Physics:
A Handbook for Teachers and Students*

Objective: To familiarize the student with the fundamental concepts of electronics related to nuclear medicine imaging devices



IAEA

International Atomic Energy Agency

Slide set prepared in 2015
by J. Schwartz (New York,
NY, USA)

CHAPTER 14

TABLE OF CONTENTS

- 7.1. Introduction
- 7.2. Primary radiation detection processes
- 7.3. Imaging detectors
- 7.4. Signal amplification
- 7.5. Signal processing
- 7.6. Other electronics required by imaging systems
- 7.7. Summary

7.1. INTRODUCTION

- ❑ Nuclear medicine imaging is generally based on the detection of X-rays and γ -rays emitted by radionuclides injected into a patient
- ❑ Nuclear medicine images are produced from a very limited number of photons, due mainly to the level of radioactivity that can be safely injected into a patient
 - Usually made from many orders of magnitude fewer photons than X-ray CT images
- ❑ Functional information is produced compared to the anatomical detail of CT
 - The apparently poorer image quality is overcome by the nature of the information produced

7.1. INTRODUCTION

- ❑ Photon counting can be performed due to the low levels of photons detected in nuclear medicine
 - Each photon is detected and analyzed individually
 - Valuable in enabling scattered photons to be rejected
 - In contrast to X-ray imaging where images are produced by integrating the flux entering the detectors
 - Places a heavy burden on the electronics viz. electronic noise & stability

- ❑ The signals produced in the primary photon detection process can be converted into pulses providing spatial, energy and timing information
 - used to produce both qualitative and quantitative images

7.2. PRIMARY RADIATION DETECTION PROCESSES

7.2.1. Scintillation counters

- ❑ Scintillation counter using a phosphor and photomultiplier + basic electronics
 - Used to produce analogue and digital signals to create an image
- ❑ Phosphors used in nuclear medicine:
 - Can produce 1500–67 000 optical photons/MeV
 - Light emission time: $< 1 \text{ ns} - 1 \mu\text{s}$
- ❑ Photomultiplier amplification can vary by an order of magnitude or more depending on:
 - Photocathode quantum efficiency
 - Number of dynodes

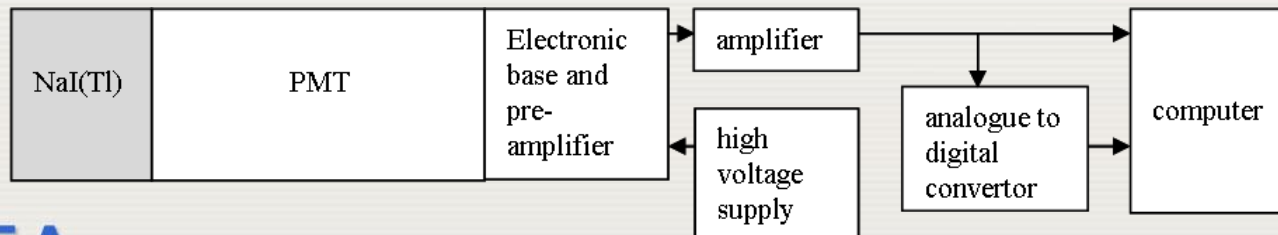

7.2. PRIMARY RADIATION DETECTION PROCESSES

7.2.1. Scintillation counters

- ❑ The pulses produced by the scintillator can vary substantially in
 - Shape
 - Amplitude
 - Electronic devices used must be flexible enough to account for these variations

- ❑ A preamplifier is needed if PMT anode signals are small
 - Incorporated into PMT electronic base to minimize the noise prior to preamplification
 - Similarly for solid state based light sensors such as photodiodes coupled to phosphors

- ❑ PMTs & photodiodes require voltage supplies to produce signals
 - PMT: 1–3 kV (each successive dynode typically requires 100–200 V) to produce sufficient amplification
 - Simple photodiode: tens of volts required to totally deplete the device
 - APD: more than tens of volts

7.2. PRIMARY RADIATION DETECTION PROCESSES

7.2.2. Gas filled detection systems

- Gas filled imaging systems convert deposited energy by a photon directly into ion pairs
 - 25–35 eV required to produce a single ion pair
 - Example: Primary signal from ^{99m}Tc will be 4000–5000 electrons
 - Signal amplified using high voltage (a few kV)
 - Multiwire proportional counter (MWPC): Produces an electron avalanche of typically 10^6 – 10^7
 - Typical dimensions of these devices for medical imaging = 30 -100 cm laterally by 10–20 cm in the direction of the γ -ray

- These signals will clearly also need amplification if they are to be used as analogue and digital output pulses for image formation

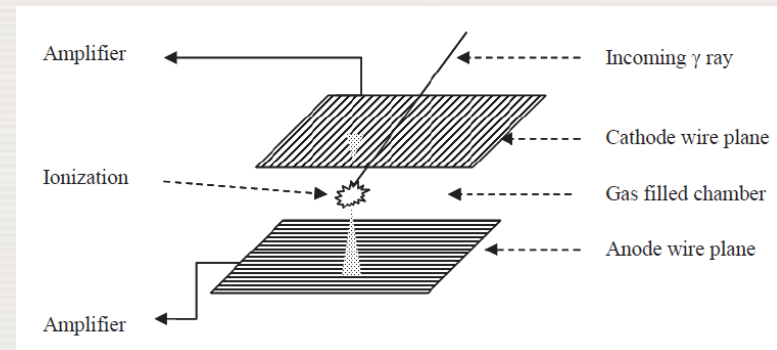

7.2. PRIMARY RADIATION DETECTION PROCESSES

7.2.3. Semiconductor detectors

- ❑ Simple diode
 - Like a solid state ionization chamber
 - Region between the p–n junction acts as e–h pairs reservoir
- ❑ Incoming radiation produces e–h pairs in the diode
 - Number of pairs proportional to deposited energy
 - An array can function as a radiation imaging device
- ❑ The energy needed to produce an e–h pair is $\sim 3\text{--}5$ eV
 - Pulses sizes varies less than for a scintillation counter
- ❑ Signals still require some form of amplification to produce useful analogue or digital information

7.3. IMAGING DETECTORS

- ❑ The two main imaging devices used are the gamma camera and the PET scanner
- ❑ For completeness, autoradiography imaging of tissue samples containing radiotracers is also described
- ❑ Generally, both gamma camera and PET systems use scintillation counters as the primary radiation detector because the stopping power for X-rays and γ -rays is good in the high density scintillating crystals used
- ❑ However, there have been some examples of cameras using MWPCs and semiconductors

7.3. IMAGING DETECTORS

7.3.1. The γ camera

- Gamma cameras are usually based on the use of single large area
 - Invented by Hal Anger
 - e.g. 50 cm \times 40 cm of NaI(Tl) coupled to up to a hundred PMTs
 - Can detect γ -rays emitted by a radiotracer distributed in the body
 - Pb collimator in front of the scintillation counter
 - Selects the direction of the γ -rays entering the device
 - Allows an image of the biodistribution of the tracer to be made

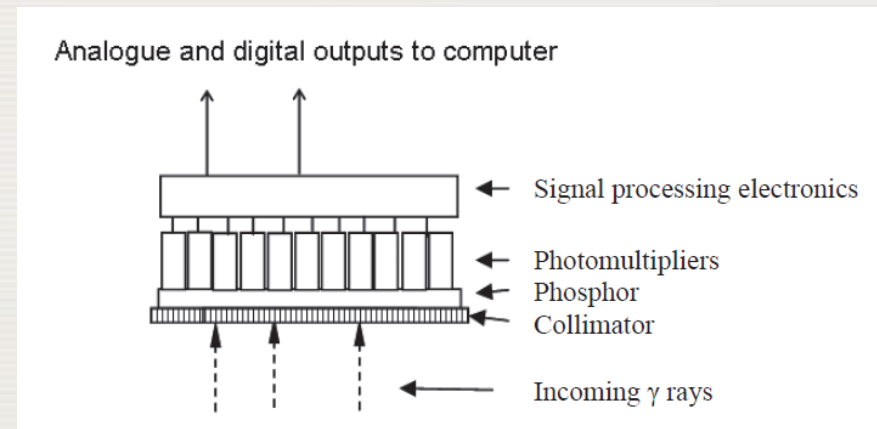

7.3. IMAGING DETECTORS

7.3.1. The γ camera

- ❑ PMT signals are proportional to the light generated in the crystal
 - Positional information can be obtained by comparing signal sizes from different PMTs
 - Energy information is related to the sum of the PMT signals
 - Energy & positional information accuracy depends on
 - Signal stability
 - Electronics used

- ❑ Analogue signal amplitudes from the PMTs depend on:
 - PMT & electronic stability
 - Noise generated in amplification process
 - Kept as low as possible by amplification close to each PMT

7.3. IMAGING DETECTORS

7.3.1. The gamma camera

- The amplified/summed signal from the PMT can be converted to a digital pulse using an analogue to digital convertor (ADC)
 - Number of pulses is proportional to pulse height / signal charge
 - Used to select events in which most of the energy of the γ -ray is detected by the camera
 - Useful tool to reduce the effect of γ -rays scattered in the body
- Need to include only PMT signals that provide information above the electronics intrinsic noise level
 - Done using some form of signal thresholding, such as a comparator

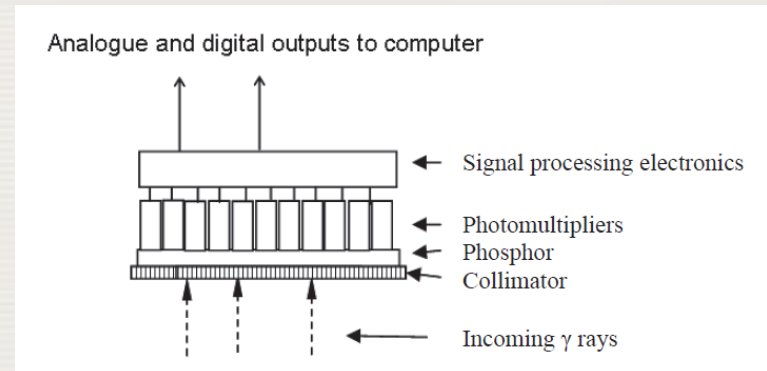

7.3. IMAGING DETECTORS

7.3.1. The γ camera

- ❑ Individual PMT pulses are digitized close to the PMTs
 - Signals are analyzed using capacitor or resistor circuits
 - Determine the positional information sent to the computer system to form the image
- ❑ The energy/pulse height centroid provides a position closely related to the point at which the γ -ray enters the crystal
 - Recent improvements uses nearest neighbour calculations
 - Based on a stored reference map of positional information
 - Provide more accurate estimates of the incident radiation entry point
 - Are more demanding computationally
- ❑ The image production accuracy is determined by:
 - initial signal sizes
 - amplification
 - digitization



7.3. IMAGING DETECTORS

7.3.2. The positron camera

□ Positron camera

- Simultaneously detects the 2 annihilation photons
 - Produced by positron emitting tracers distributed in the body
 - Detection requires the addition of coincidence circuits used to select the pulses from a single annihilation event
- Made of many thousands of small scintillating crystals + thousands of PMTs
- Many more amplifiers which may have to function at higher count rates than in a gamma camera

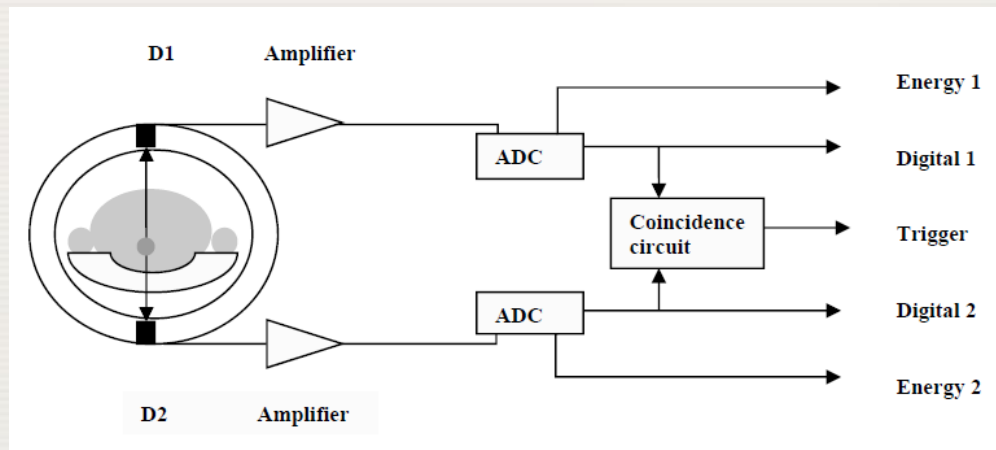

7.3. IMAGING DETECTORS

7.3.2. The positron camera

- ❑ Main electronics difference between PET & γ -cameras
 - Large number of PMT channels involved
 - Count rates achieved
 - Factors of 10–20 are not unusual
- ❑ PET camera pulses must be carefully shaped
 - Allow accurate timing information in coincidence circuits
 - Ensure that both annihilation photons from a single event are detected
 - Affected time jitter in the pulses
 - Random photons from multiple nucleic decays included in the data acquisition
- ❑ Recently introduced ‘time of flight’ (TOF) cameras
 - Require very accurate (sub-ns) timing between the 2 annihilation photons



7.3. IMAGING DETECTORS

7.3.2. The positron camera

- Typical signal processing in a phosphor/photomultiplier tube based positron camera
- Pulses from two opposing detectors in the camera array are amplified, digitized, checked for coincidence and then used to provide positional and energy information for the event detected

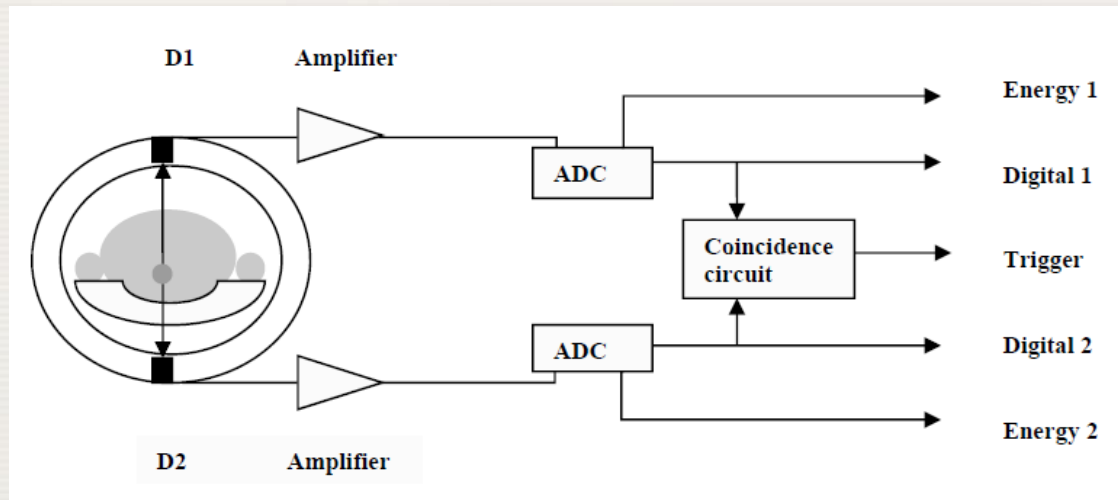

7.3. IMAGING DETECTORS

7.3.3. Multiwire proportional counter based X-ray and γ -ray imagers

- ❑ X/ γ photons generate an ionization signals in the gas
 - Signal is detected by the anode and cathode wire planes
 - High voltages across wire planes
 - Cause electron avalanches close to nearest wires
 - Signals can be detected and amplified at either end of the wire

- ❑ *Example of use:* PETRRA positron camera
 - Initial γ -ray detection performed with blocks of BaF
 - Vacuum UV produced in the crystal photo-ionizes the gas
 - Producing electrons
 - Electrons subsequently amplified in the gas by a series of wire planes
 - Produced pulses provide fast coincidence trigger to read the data into the computer
 - Achievable timing resolution = 2–3 ns

7.3. IMAGING DETECTORS

7.3.3. Multiwire proportional counter based X-ray and γ -ray imagers

- Positional information is read out using delay lines coupled to the cathode wires
 - Signals are detected at either end using amplifiers
 - Produce signals with low time jitter

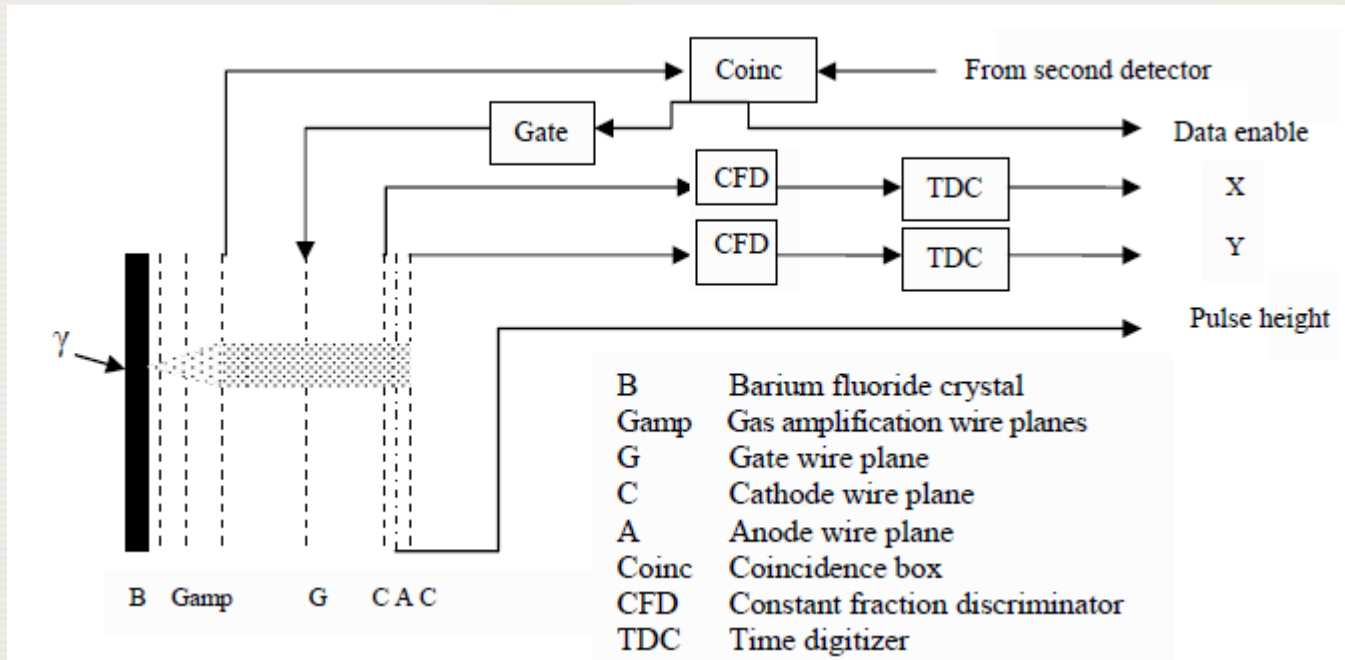

7.3. IMAGING DETECTORS

7.3.3. Multiwire proportional counter based X-ray and γ -ray imagers

- Signals are passed to constant fraction discriminators (CFDs)
 - Produce fast timing signals
- Passed to time digitizers
- Time difference between signals' arrival at the 2 ends of the delay line is measured by
 - Time to digital convertors (TDCs)
 - Provides the positional information
 - Accuracy of information depends on
 - Delay lines intrinsic properties
 - Spread of signal at the wire planes (4 mm)

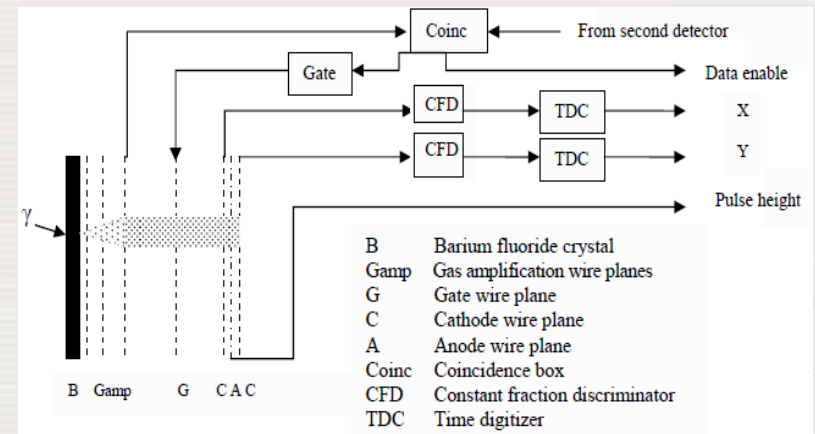

7.3. IMAGING DETECTORS

7.3.3. Multiwire proportional counter based X-ray and γ -ray imagers

- ❑ Use of an electronic 'gate' to further minimize time needed to record single γ -ray events
 - Ionization signals transport is controlled by additional wire plane
 - Ionization is passed to anode/cathode only if 2 MWPCs are triggered in fast coincidence
- ❑ Anode signals can be used to measure the pulse height produced by each detected γ -ray
- ❑ Overall, the electronics of this camera have to manage count rates of several megahertz
- ❑ Similar detectors have been developed for imaging:
 - Low energy γ -rays
 - Animal imaging
 - Tissue autoradiography



7.3. IMAGING DETECTORS

7.3.4. Semiconductor imagers

- ❑ There have been several attempts to make nuclear medicine imaging devices using semiconductors as a γ -ray camera
- ❑ Need high Z material presently only have potential as primary γ detector
 - Ge
 - GeLi has been used as 2-D strip detector
 - Signals from amplifiers at the end resistor chains could be used to determine interaction position in the sensor
 - Impractical because:
 - Modest stopping power
 - Need a cryostat to reduce intrinsic detector noise

7.3. IMAGING DETECTORS

7.3.4. Semiconductor imagers

➤ CZT

- More practical
- Room temperature
- Developed by GE
 - Alcyone system
 - Spectrum Dynamics -- DSPECT
 - Specifically for cardiac imaging
 - 1000 individual small crystals coupled to a tungsten collimator
 - Sensitivity ~ 8x scintillator camera
 - Spatial resolution = 3.5–4.2 mm FWHM

7.3. IMAGING DETECTORS

7.3.4. Semiconductor imagers

□ Silicon photodiodes

- Used as an alternative to PMTs for both gamma camera and PET scanners
- APDs have been coupled to phosphors and because of their small size, a truly digital camera design is possible
 - Only small systems have been developed due to cost

□ The recent development of silicon photomultipliers promises further improvements in nuclear medicine imaging

7.3. IMAGING DETECTORS

7.3.5. The autoradiography imager

□ Autoradiography

- Based on the use of radioactive labels with
 - Long lived radiotracers
 - Short range β / low energy X-ray / γ -ray emission
 - Short range beta or low energy X or γ -ray emission
 - Examples: Tracers ^3H , ^{14}C , ^{32}P , ^{33}P and ^{125}I
- Used to determine microscopic pharmaceuticals distribution in excised tissues
 - In humans: used to detect areas of malignancy or tissue malfunction
 - In animals: e.g. used used to track the uptake of drugs
- High efficiency imagers are required to detect emissions
 - Levels of uptake in tissue samples are often very low

7.3. IMAGING DETECTORS

7.3.5. The autoradiography imager

- ❑ The gold standard for tissue radiography is film emulsion
 - High resolution (μm) image of tissues
 - Low efficiency for detecting radiation involved
 - Images take days to weeks to produce
 - Severe limitation when diagnostic information is desired

- ❑ Digital autoradiography systems
 - Based on the use of
 - thin phosphors
 - gas filled detectors
 - silicon wafers
 - 50–100 times more efficient
 - Limited spatial resolution: few tens of μm

7.3. IMAGING DETECTORS

7.3.5. The autoradiography imager

□ Phosphor based imager

- May use a very thin (50–100 μm) material such as one of:
 - GADOX
 - CsI(Tl)
- Coupled to a high resolution sensor such as:
 - Microchannel plate
 - Charge coupled device
 - Complementary metal oxide semiconductor (CMOS) APD
- Limitations are mostly
 - Sensor pixel size
 - Noise in the sensor

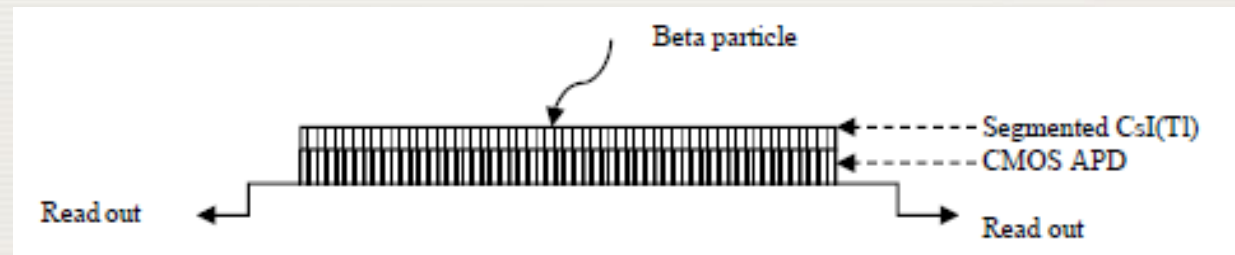

7.3. IMAGING DETECTORS

7.3.5. The autoradiography imager

□ Phosphor based imager

- Require amplifiers with low noise
- Room temperature operation desirable
- Resolution of $<50 \mu\text{m}$
- MWPC based imagers
 - Sample placed in contact with gas chamber
 - Resolution = few hundred μm
- Direct β 's & X-rays detection using
 - Charge coupled devices OR
 - CMOS APDs
 - Further improve resolution (few μm)
 - ^3H can be imaged

7.4. SIGNAL AMPLIFICATION

- ❑ Primary radiation detectors signals are generally small
 - Need amplification without adding high levels of noise into the signal readout system
 - If signals are very small, need prior pre-amplification
 - Example: PMT has insufficient dynodes to provide a large pulse
- ❑ Preamplifiers are mounted immediately next to or as part of the detector output stage to minimize the noise produced prior to full amplification
- ❑ Main amplifier can be used to maximize and shape the signal without over-amplifying noise via
 - Current gain
 - Voltage gain

7.4. SIGNAL AMPLIFICATION

7.4.1. Typical amplifier

- ❑ Output current from PMT
 - Directly proportional to amount of light received from phosphor
 - Still very small
 - Amplifiers specially designed to transform it into voltage
 - Can be directly input into an ADC or comparator
- ❑ Capacitor is used for optimum signal to noise ratio
 - Integrated output current pulse
 - Arranged in the feedback circuit of a wide bandwidth voltage amplifier
 - High input impedance
 - Extremely small input current
 - Frequency range of the amplifier must be able to cope with high data rates (tens of kHz to MHz)
- ❑ PMT anode is ideally connected directly to the charge amplifier input
 - A high value resistor providing a DC return path



7.4. SIGNAL AMPLIFICATION

7.4.1. Typical amplifier

□ Charge amplifiers integrate the current from the PMT

- Produces an output voltage pulse
- The output voltage of a typical charge amplifier is:

$$V_{\text{out}} = -\frac{1}{C} \int I(t) dt = -\frac{Q}{C}$$

□ A negative feedback

- Increases the effective input capacitance by a factor equal to the amplifier gain
- Almost all of the current flows into the amplifier
- Reduces the output impedance
- Amplifier acts as a voltage source

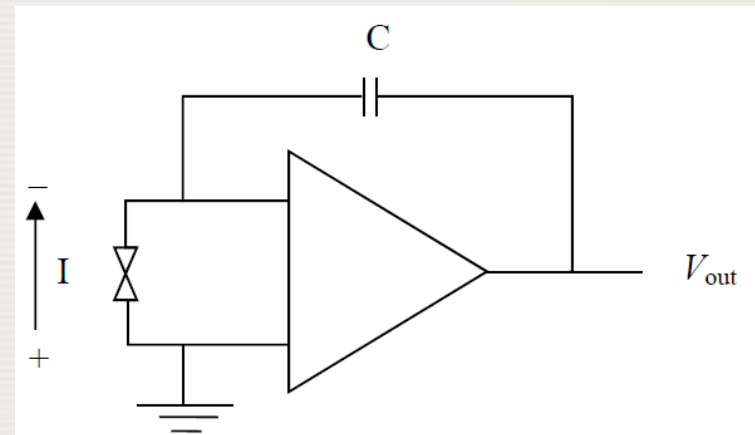

7.4. SIGNAL AMPLIFICATION

7.4.1. Typical amplifier

- Output pulse shape is important for
 - Analogue and digital information measurement
 - Defined by the output stage of the amplifier

- The amplified signal is first passed through a CR (high pass) filter
 - Attenuates
 - Low frequencies contain
 - A lot of noise
 - Very little signal
 - Improves the signal to noise ratio
 - Pulse decay time is shortened

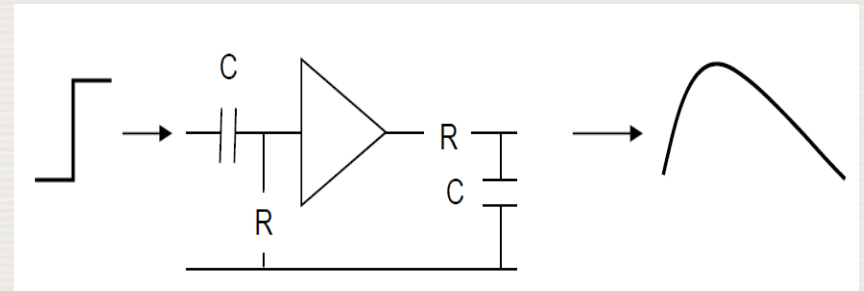

7.4. SIGNAL AMPLIFICATION

7.4.1. Typical amplifier

- ❑ Pulse passes through RC (low pass) filter
 - Before the output of the amplifier
 - Attenuates high frequencies, which contain excessive noise
 - Improves the signal to noise ratio
 - Pulse rise time is lengthened

- ❑ The combined effect produces
 - Unipolar output pulse
 - Has an optimal signal to noise ratio

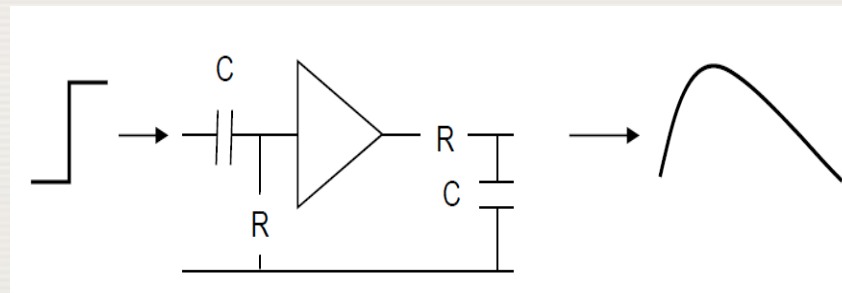

7.4. SIGNAL AMPLIFICATION

7.4.2. Properties of amplifiers

□ Gain

- Often expressed in mV output/pC input charge

$$\text{gain[dB]} = 10 \log \frac{P_{\text{out}}}{P_{\text{in}}}$$

□ Bandwidth

- Range of frequencies that the amplifier operates
- Often determined by frequencies at which the P_{out} drops to $\frac{1}{2}$ its normal value (-3 dB point)
- Important for an amplifier attached to a high count rate detector
 - *Example:* PET detectors

7.4. SIGNAL AMPLIFICATION

7.4.2. Properties of amplifiers

□ Linearity

- Limited when the gain is increased to saturation point
 - Resulting in output pulse distortion
- Important if the dynamic range is large

□ Dynamic range

- Ratio of smallest & largest useful output signals
- Smallest limited by system noise
- Largest limited by amplifier distortion

7.4. SIGNAL AMPLIFICATION

7.4.2. Properties of amplifiers

□ Slew rate

- Maximum rate of change of the shape of the output signal for the whole range of input signals
- Usually expressed in V/ms
- Important if timing information is needed
- Poor slew rate distorts bigger signals
 - Unsuitable for fast timing
 - Example: PET rise times are need to be ~ few ns

□ Rise time

- Time for the output pulse to increase from 10–90% of its maximum
- Measure of the amplifier speed / frequency response

7.4. SIGNAL AMPLIFICATION

7.4.2. Properties of amplifiers

❑ Ringing

- A pulse produced that oscillates before:
 - Reaching its maximum
 - Tail oscillates before reaching the baseline
- Serious problem if :
 - Timing information is required
 - Multiple output electronics triggers are produced

❑ Overshoot

7.4. SIGNAL AMPLIFICATION

7.4.2. Properties of amplifiers

□ Stability

- Positional, energy and timing information determination rely on output constancy for constant input
- Both in offset, amplitude and shape
- Affected primarily by variations in
 - temperature
 - supply voltage
 - count rate
 - long term drift

7.4. SIGNAL AMPLIFICATION

7.4.2. Properties of amplifiers

□ Noise

- Major impediment to image production
- Examples
 - Thermal noise from thermal movement of charge carriers in resistors
 - Shot noise from random variation in the number of charge carriers
 - Flicker or 1/f noise
- Caused by the trapping /collisions of charges in the electronics Si structure
- Produce variations in the output signal of detector/electronics system t
 - Can affect the quality of images

7.4. SIGNAL AMPLIFICATION

7.4.2. Properties of amplifiers

□ Noise

- Root mean square noise

$$\sqrt{\sum (\text{noise variance})^2}$$

- Noise in systems using:
 - PMTs: Dominated by the number of photoelectrons produced at the photocathode
 - Gas filled detector: Dominated by number of primary electrons at the first stage
 - Si detector: Dominated by initial number of e–h pairs produced

7.5. SIGNAL PROCESSING

- ❑ Once an amplified signal has been produced, it is then used to generate both analogue and digital information about the detected event

- ❑ The analogue signal will relate to the energy deposited in the detector
 - Used to minimize the number of scattered γ -rays accepted into the image production process
 - The digital signal is used to produce spatial and timing information

7.5. SIGNAL PROCESSING

7.5.1. Analogue signal utilization

- ❑ The analogue information is generated by sending the pulse from the amplifier into a single or multichannel pulse height analyzer
- ❑ In a gamma camera
 - Several 'energy windows' are available
 - Pulse height / charge is compared with preset values
 - There's a preset corresponding to known γ -rays energies
 - To image with single energy γ -ray emission
 - Set 2 thresholds
 - Reject pulses above/below these values
 - To image when a radiotracer that emits several γ -rays
 - Multiple thresholds can be set
 - Sort the information into several channels or images

7.5. SIGNAL PROCESSING

7.5.1. Analogue signal utilization

□ Single channel pulse height analyzer

- An output pulse is produced when the input pulse is between the two thresholds
- This system also functions as a single channel analogue to digital converter

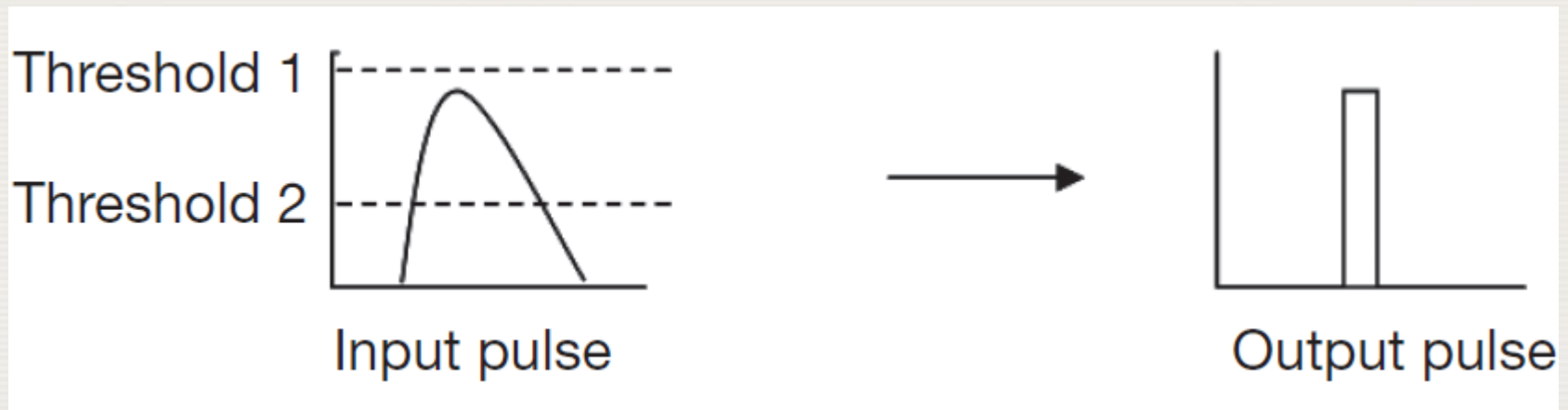

7.5. SIGNAL PROCESSING

7.5.2. Signal digitization

- ❑ Analogue signals are converted into digital signals using an ADC
- ❑ The digitization method uses a single slope converter
- ❑ Digital signals are subsequently used to provide spatial & temporal information about each detected event
- ❑ Ramp-based single slope converter system for digitizing analogue pulses

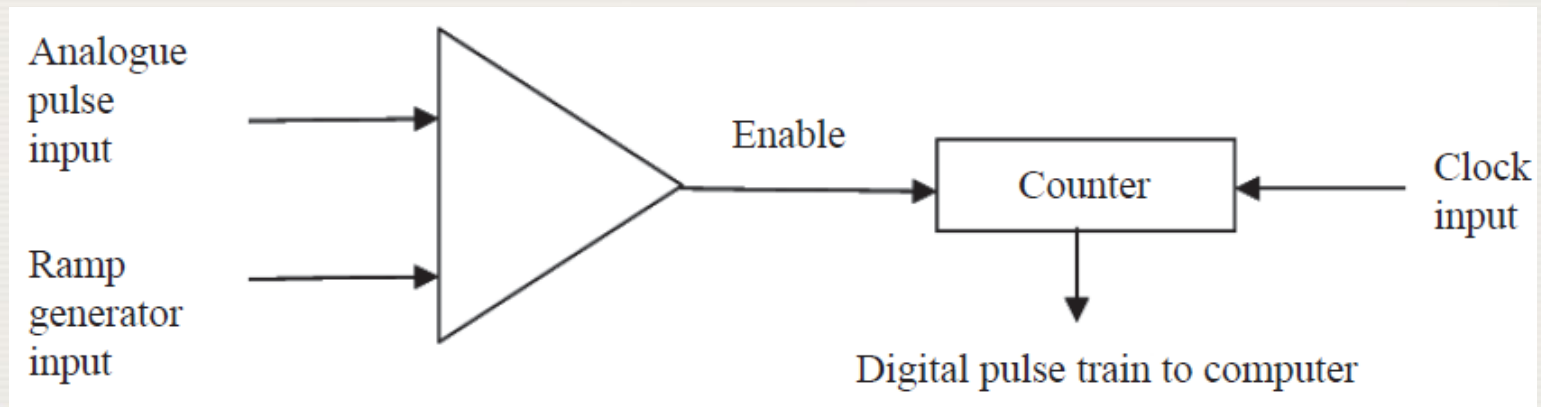

7.5. SIGNAL PROCESSING

7.5.2. Signal digitization

□ Pulse sequence from the system

- A ramp signal is generated
- A clock producing digital output pulses is started at the same time
- The clock is stopped when the ramp signal exceeds the input pulse
- The number of pulses generated corresponds to the signal amplitude
- Higher accuracy of digitization achieved with a faster clock
 - Relatively simple & low cost solution
 - Slow since the time taken to digitize the pulse is 2^N clock cycles
- Accurate conversion requires a constant analogue pulse shape

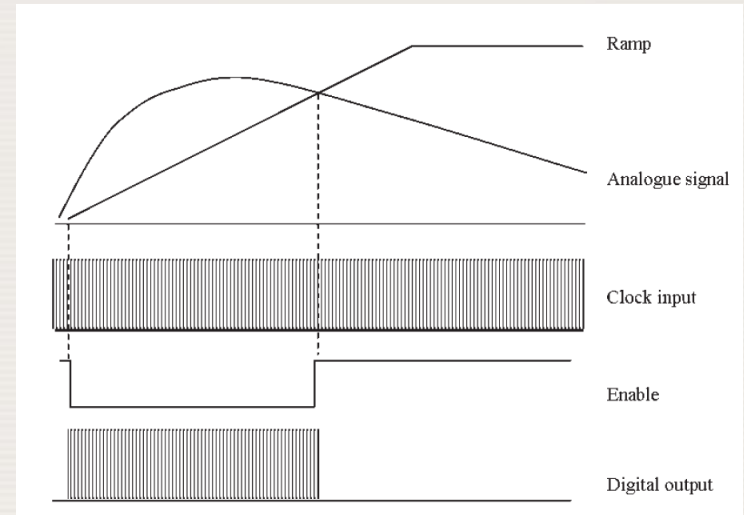

7.5. SIGNAL PROCESSING

7.5.2. Signal digitization

□ A faster method of digitization possible by using flash ADC

- Uses a large number of comparators
 - Each having a different reference level
 - The output from each is the input into a logic box that produces the multiple bits of the digital signal
 - Need $2^N - 1$ comparators if N-bit output is needed
- Takes a single clock cycle
- System cons:
 - Complex
 - Expensive
 - Consumes a lot of power
- Nuclear medicine typically needs 8-12 bits

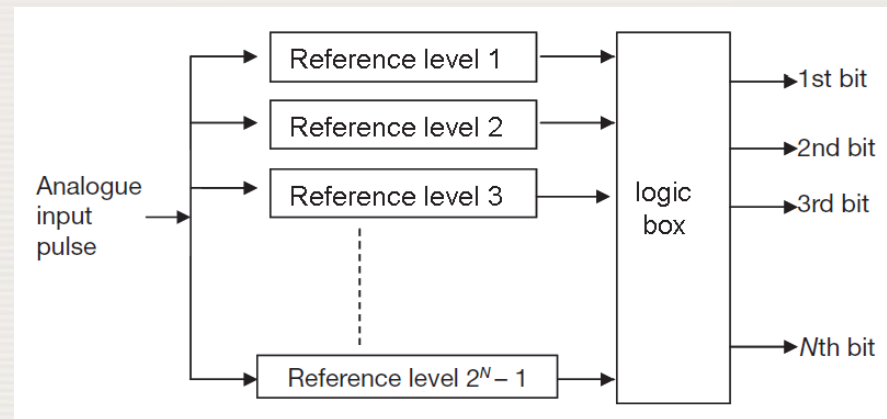

7.5. SIGNAL PROCESSING

7.5.3. Production and use of timing information

□ Timing of events in PET systems is very important

- Only pairs of annihilation photons from the same decay contribute to the image
- Fast timing is required for coincidence imaging and time of flight measurement
 - Single count rates may be very high
 - Based on the front edge timing of 2 pulses by either:
 - ‘Zero crossing’ point of the differentiated pulses
 - Using a constant fraction method
 - Problems:
 - Variation in analogue signal pulse heights
 - Produces a large variation in timing

7.5. SIGNAL PROCESSING

7.5.3. Production and use of timing information

How 2 pulses from PET detectors are used to generate a coincidence with CFDs

- CDF for fast coincidence output
- Timing trigger points occur at a constant fraction of the analogue signal
- The timing is not affected by the different signal pulse heights
- CFD1 generates a gate with a width $> 2 \times$ timing resolution
- A coincidence (AND) output is generated if CFD2 pulses fall within gate
- Otherwise, the event is rejected

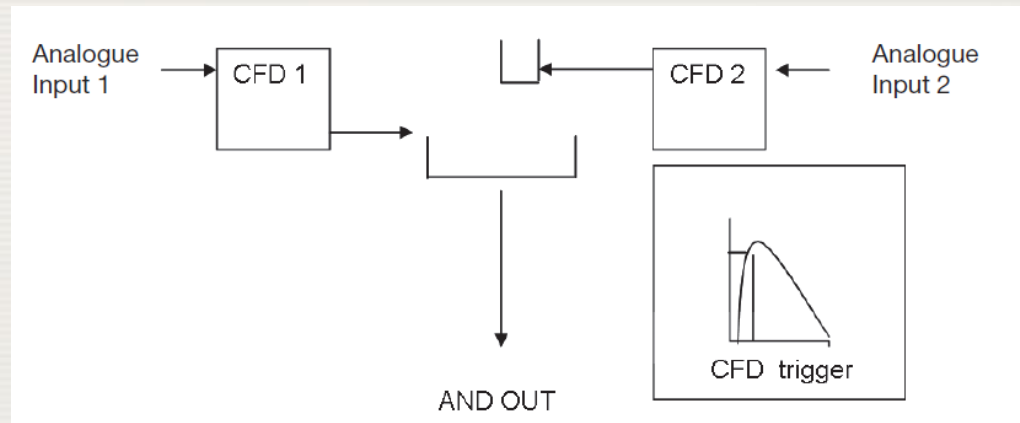

7.5. SIGNAL PROCESSING

7.5.3. Production and use of timing information

□ Alternatively use the zero crossing

- Pulse is differentiated to produce a bipolar pulse
- Timing is taken from the point where the pulse crosses a reference line usually tied to ground
- Pulse shapes must be carefully controlled to minimize jitter timing

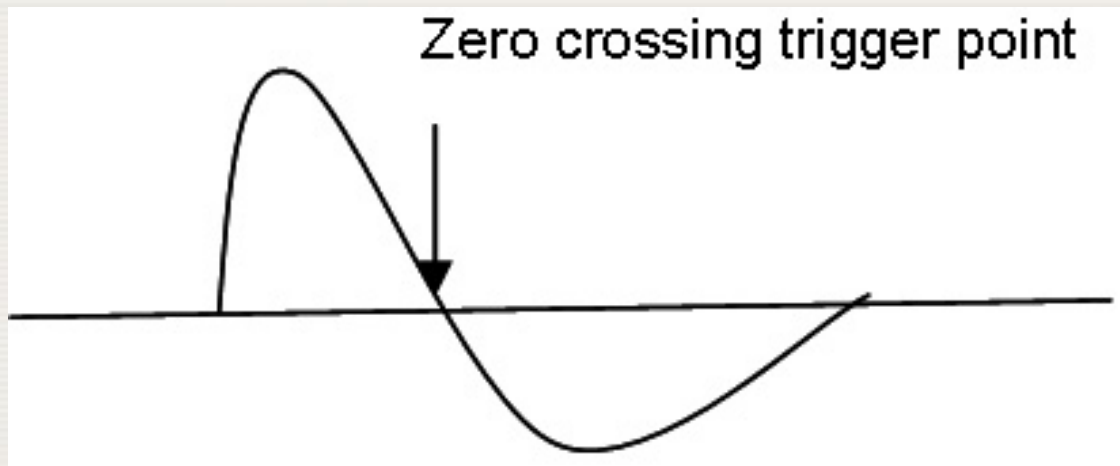

7.5. SIGNAL PROCESSING

7.5.3. Production and use of timing information

- ❑ If the timing information is to be stored, then the two pulses from the CFDs can be input into a TDC
- ❑ In this case, the first pulse starts and the second one stops a clock
- ❑ The number of pulses generated is proportional to the time difference between the pulses
- ❑ If a fast clock is used, excellent timing information is available, e.g. for use in time of flight calculations

7.6. OTHER ELECTRONICS REQUIRED BY IMAGING SYSTEMS

7.6.1. Power supplies

- ❑ Low voltage supplies provide the power input for semiconductor systems where a few tens of volts are sufficient
- ❑ In some cases, batteries may provide enough power but the need to maintain a constant current and voltage makes this a modest solution
- ❑ A low voltage supply converts main AC power into DC
 - AC typically 240 V (or 110 V)
 - DC, for example, ± 15 V and ± 5 V
 - Provide the line voltages for transistors and diodes
 - This is done by half-wave, full-wave and 3-phase-wave rectification

7.6. OTHER ELECTRONICS REQUIRED BY IMAGING SYSTEMS

7.6.1. Power supplies

□ Half-wave rectification, combining:

- A transformer to reduce the voltage
- A rectifier
 - Typically a diode
 - Allows only $\frac{1}{2}$ of the AC signal to pass

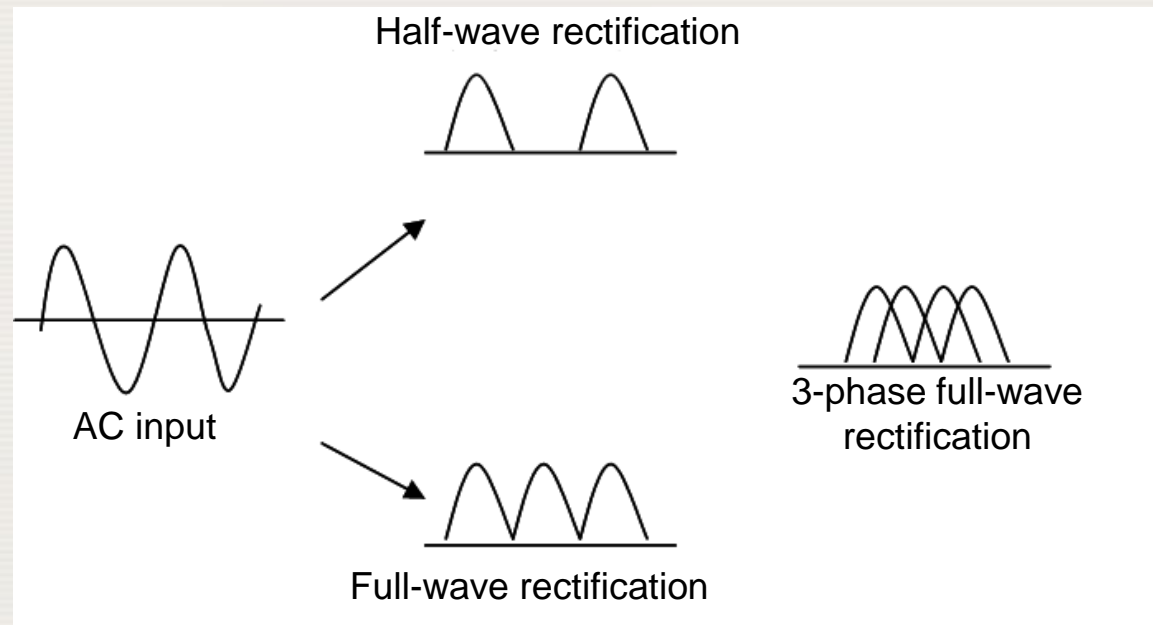

7.6. OTHER ELECTRONICS REQUIRED BY IMAGING SYSTEMS

7.6.1. Power supplies

□ Full-wave rectification

- Achieved by using a diode bridge
- Allows both halves of the AC signal to be used
- $\frac{1}{2}$ of the wave is inverted
- Oscillations are removed using a filter
- Usually capacitors

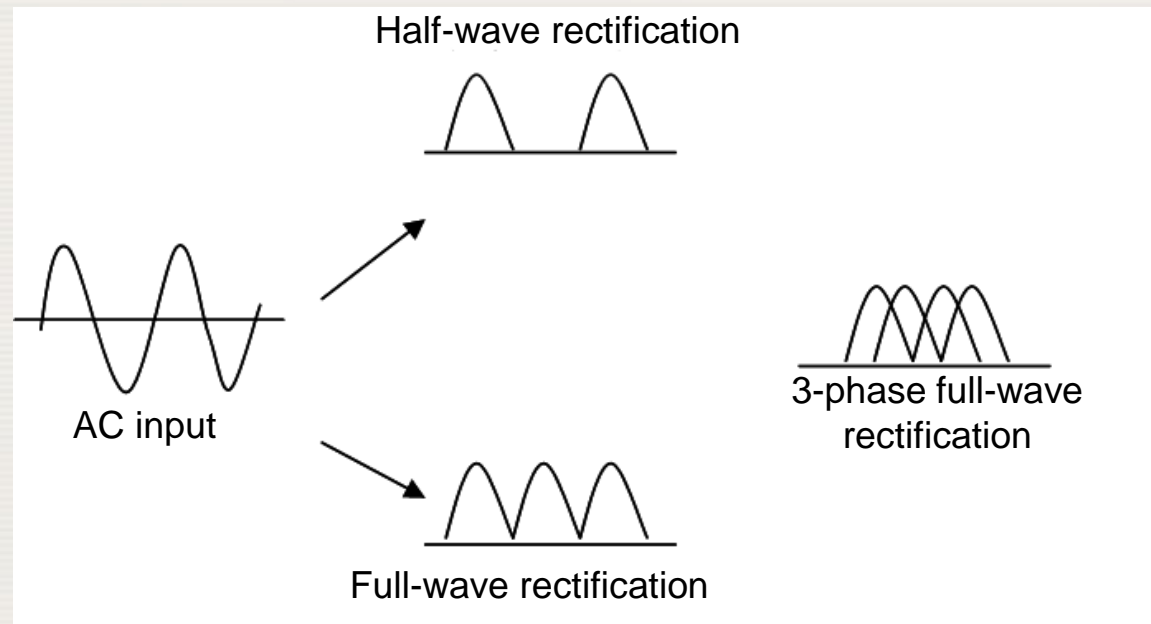

7.6. OTHER ELECTRONICS REQUIRED BY IMAGING SYSTEMS

7.6.1. Power supplies

□ 3-phase-wave rectification

- Provides smoothest DC output
- Uses a 3-phase AC input
- The output is passed through a voltage regulator
- Stabilizes the voltage
- Removes the last traces of ripple

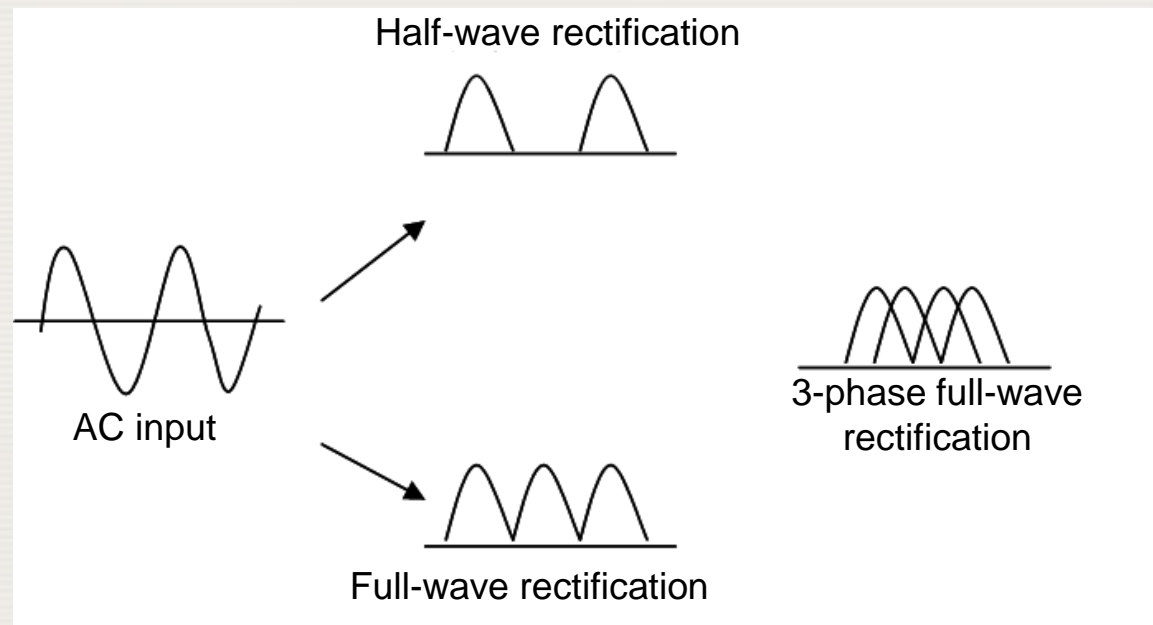

7.6. OTHER ELECTRONICS REQUIRED BY IMAGING SYSTEMS

7.6.1. Power supplies

- ❑ PMTs and MWPCs require power supplies that can provide voltages up to several kV
- ❑ For example, each pair of dynodes in a PMT usually has at least 100 V between them
- ❑ Even more may be used between the photocathode and the first dynode to maximize the early gain of the PMT
- ❑ These power supplies usually have an oscillator and step-up transformer operating at high frequency to provide the drive plus a voltage multiplier consisting of a stack of diodes and capacitors

7.6. OTHER ELECTRONICS REQUIRED BY IMAGING SYSTEMS

7.6.2. Uninterruptible power supplies

- ❑ Needed for an imaging system to overcome loss of power during periods of mains supply interruption
- ❑ Output power comes from the storage battery via some form of inverter
- ❑ While the mains power is available
 - Battery charges
 - Provides power to the imaging device
- ❑ If the mains supply is interrupted
 - Battery continues to provide support
 - Ensure that the imaging system can continue to be used

7.6. OTHER ELECTRONICS REQUIRED BY IMAGING SYSTEMS

7.6.2. Uninterruptible power supplies

- ❑ The size of the battery support system depends directly on
 - How long backup is needed
 - How long it takes the operator to save data and shut down the system

- ❑ The mains is replaced by a generator supply in most imaging environments
 - The period of support is often short
 - Several hours of supply is available from an uninterruptible power supply

7.6. OTHER ELECTRONICS REQUIRED BY IMAGING SYSTEMS

7.6.3. Oscilloscopes

- ❑ Essential in order to optimize the use of pulse generating equipment
- ❑ Can be used to
 - Display pulses from the detectors at various stages of generation prior to their use in image production
 - Provide the optimum analogue & digital pulse sequence, shape and size
 - Function as a spectrum analyser over a wide range of pulse frequencies
- ❑ The pulses are displayed on a 2-D display
 - Vertical axis usually represents voltage (pulse height)
 - Horizontal axis usually represents time
- ❑ The display can also be used to
 - Analyze frequency of the signals
 - Detect any pulse distortion (e.g. oscillation or saturation)



7.6. OTHER ELECTRONICS REQUIRED BY IMAGING SYSTEMS

7.6.3. Oscilloscopes

□ Displays

- Originally based on a cathode ray tube
- More modern ones use liquid crystal displays with ADCs & other processing electronics
- More recently, it has been possible to install oscilloscope software onto a computer

□ The input from equipment can be done either

- Directly with connecting cables/sockets
- Through probes
 - Often into a high impedance (e.g. 1 M Ω)
 - 50 Ω for high frequency signals

7.6. OTHER ELECTRONICS REQUIRED BY IMAGING SYSTEMS

7.6.3. Oscilloscopes

- ❑ The timebase control can adjust the horizontal display between 10 ns – sec

- ❑ The pulse height control from mV to V

- ❑ Other controls:
 - Beam finder, spot brightness and focus, graticule control (visual grid measurement), pulse polarity and trigger level controls, horizontal and vertical extent and position controls, selection of trigger source (particularly useful for pulse coincidence display) and sweep controls

7.7. SUMMARY

- ❑ The information provided above gives a general overview of the equipment and electronics used in nuclear medicine imaging
- ❑ In some cases, manufacturers have developed special multichannel electronics readout systems tailored to the detectors
- ❑ These systems include the individual electronics elements described above in a compact design that increases speed and accuracy
- ❑ Such systems are usually specific to the device involved