

Chapter 11: Nuclear Medicine Imaging Devices

Slide set of 185 slides based on the chapter authored by M.A. Lodge, E. C. Frey of the IAEA publication (ISBN 978–92–0–143810–2):
*Review of Nuclear Medicine Physics:
A Handbook for Teachers and Students*

Objective:

To familiarize the student with the basic principles of operation of nuclear medicine imaging devices.



IAEA
International Atomic Energy Agency

Slide set prepared in 2015
by R. Fraxedas (INEF,
Havana, Cuba)

- 11.1 Introduction
- 11.2 Gamma camera systems
- 11.3 Positron emission tomography systems
- 11.4 SPECT/CT and PET/CT systems

11.1 INTRODUCTION



11.1 INTRODUCTION

Major imaging systems categories

Gamma camera systems

- ❑ Planar gamma cameras (2-D images)
- ❑ Single photon emission computed tomographic systems
 - SPECT (3-D images)

Positron emission tomography systems

- ❑ Tomographic systems
 - PET (3-D images)

11.1 INTRODUCTION

MULTIMODALITY SYSTEMS

SPECT/CT

PET/CT

The CT images provide an anatomical reference frame for the functional images and allow for attenuation correction

11.2 GAMMA CAMERA SYSTEMS

11.2.1 Basic principles

11.2 GAMMA CAMERA SYSTEMS

11.2.1 Basic principles

Basic elements of gamma camera systems

- ❑ Collimator
 - Defines lines of response
- ❑ Radiation detector
 - Counts the incident gamma photons
- ❑ Computer system
 - Creates 2-D images from detector data
- ❑ Gantry system
 - Supports and moves gamma camera and patient

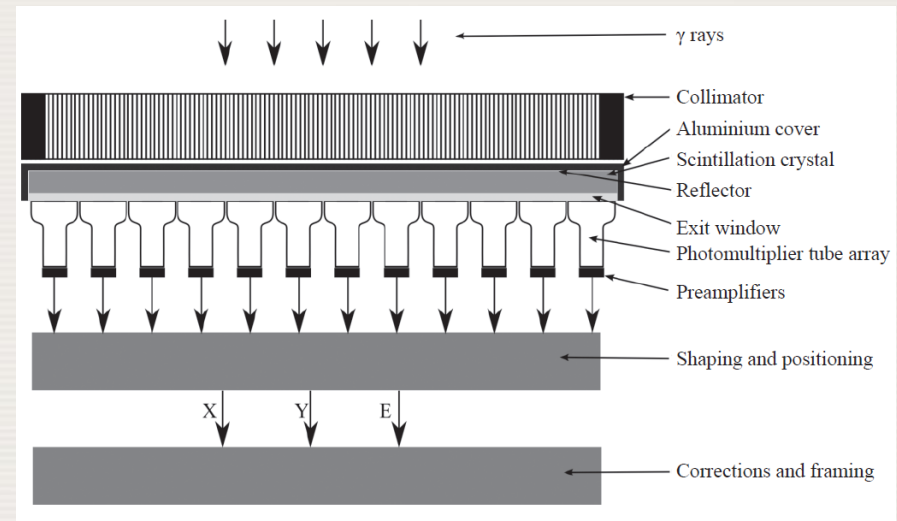

Schematic diagram showing the major components of a gamma camera

11.2 GAMMA CAMERA SYSTEMS

11.2.1 Basic principles

Collimators

- ❑ Collimators are used as mechanical lenses, to provide information about the activity on a unique line through the object called the line of response (LOR).
- ❑ The collimator prevents photons emitted along directions that do not lie along the LOR from reaching the detector.

11.2 GAMMA CAMERA SYSTEMS

11.2.1 Basic principles

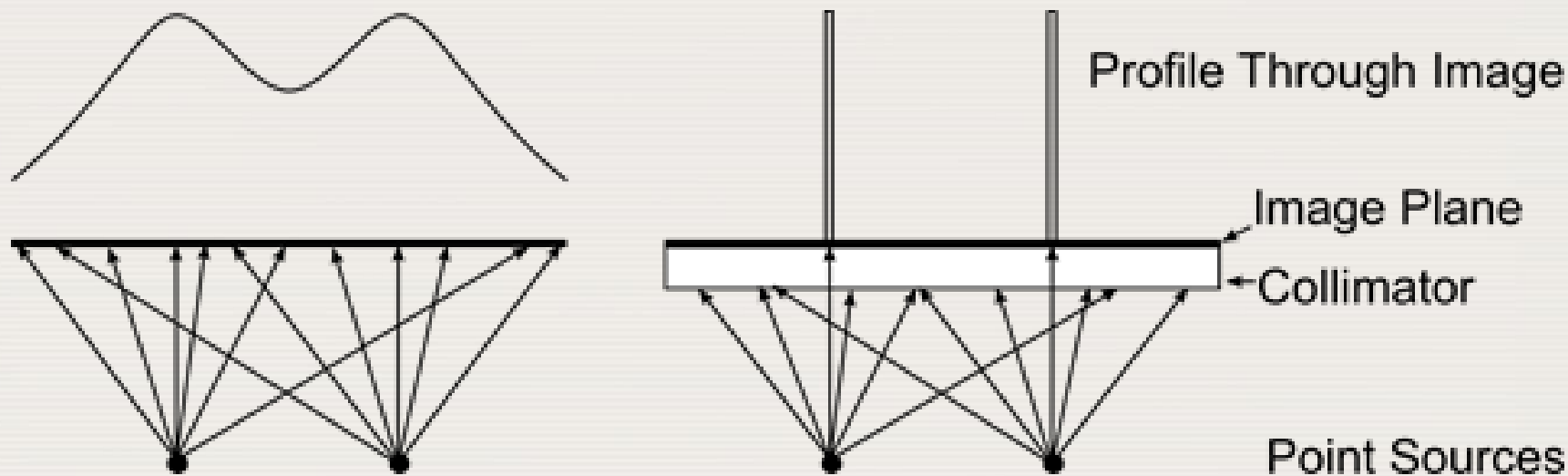

Left: without the collimator, there is very little information about the origin of the photons.
Right : with the collimator, points on the image plane are uniquely identified with a line in space.

11.2 GAMMA CAMERA SYSTEMS

11.2.2 The Anger camera

11.2 GAMMA CAMERA SYSTEMS

11.2.2 The Anger camera

11.2.2.1 Collimators

Hole dimensions, resolution and number of photons detected

- Smaller hole diameters or longer lengths increase the resolution of the collimator.
- Conversely, the number of photons detected decreases and image noise increases

11.2 GAMMA CAMERA SYSTEMS

11.2.2 The Anger camera

11.2.2.1 Collimators

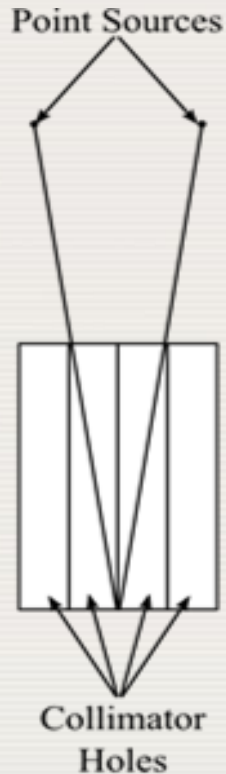

Collimator holes and resolution
The lines from the point source through the collimator indicate the furthest apart that two sources could be and still have photons detected at the same point on the image plane.

11.2 GAMMA CAMERA SYSTEMS

11.2.2 The Anger camera

11.2.2.1 Collimators

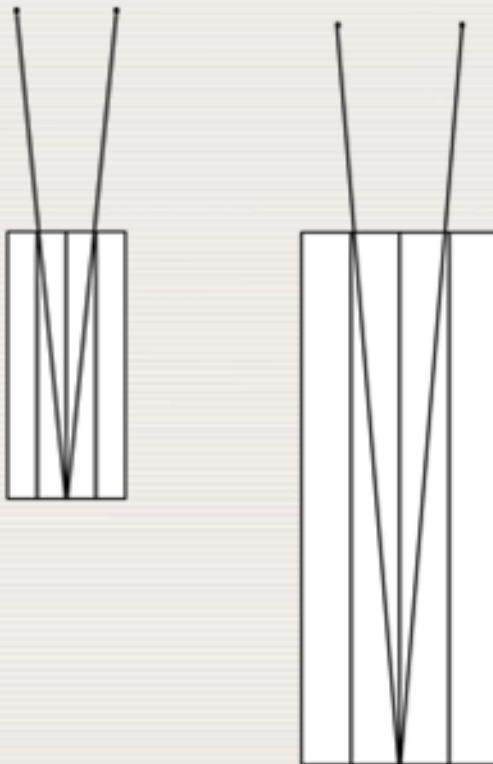

Collimator holes and resolution
Resolution improves with a reduction in the width of the collimator holes and improves with the hole length.

11.2 GAMMA CAMERA SYSTEMS

11.2.2 The Anger camera

11.2.2.1 Collimators

Collimators and energy range

- Ideally, collimator septa should block all incident radiation.
- In a real collimator, a fraction penetrates septa or are scattered and detected.
- Septal penetration and scatter increases with energy. Thus, collimators are designed for energy ranges.

11.2 GAMMA CAMERA SYSTEMS

11.2.2 The Anger camera

11.2.2.1 Collimators

Collimators according to energy range

Low energy collimators

$$E_{\gamma} < 160 \text{ keV}$$

Medium energy collimators

$$160 < E_{\gamma} < 250 \text{ keV}$$

High energy collimators

$$E_{\gamma} > 250 \text{ keV}$$

Energy range should take into account high energy photons, even if not included in the image.

11.2 GAMMA CAMERA SYSTEMS

11.2.2 The Anger camera

11.2.2.1 Collimators

Hole shape

- Hole shape is important in collimator design.
- The most common hole shapes are:
 - Round
 - Hexagonal
 - Square
- Hexagonal holes are the most common in continuous crystal cameras.

11.2 GAMMA CAMERA SYSTEMS

11.2.2 The Anger camera

11.2.2.1 Collimators

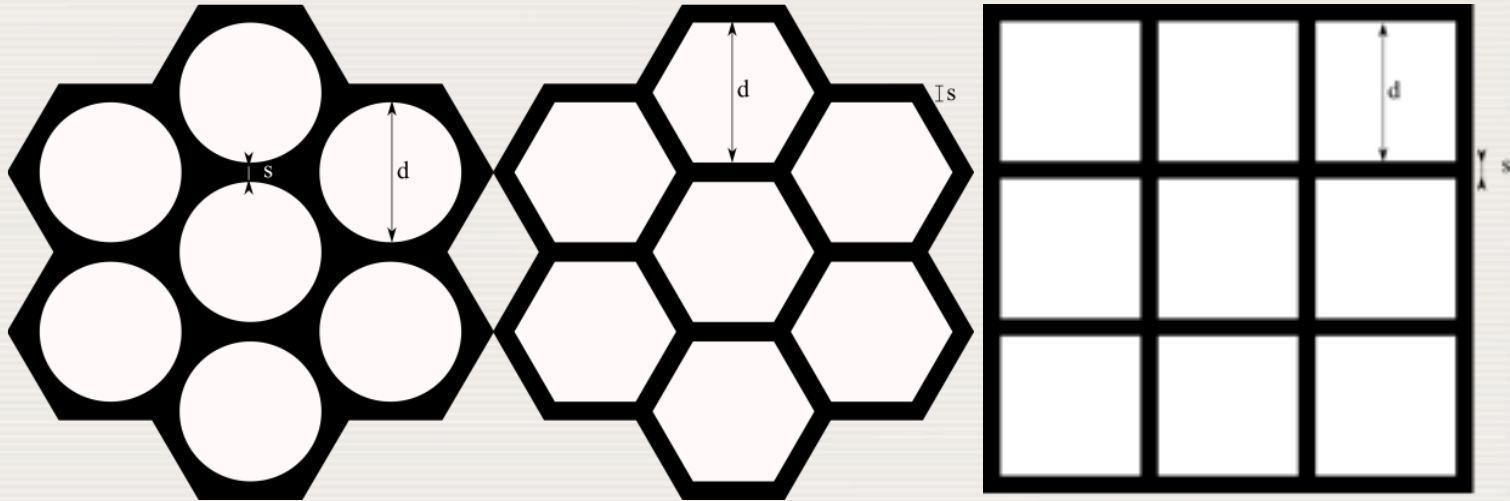

Major hole shapes: round, hexagonal and square. (d: diameter; s: septal thickness)

11.2 GAMMA CAMERA SYSTEMS

11.2.2 The Anger camera

11.2.2.1 Collimators

Collimators according to fabrication techniques

Cast

- Usually used for medium and high energy collimators

Foil

- Appropriate for low energy collimators, as septa can be made thinner

11.2 GAMMA CAMERA SYSTEMS

11.2.2 The Anger camera

11.2.2.1 Collimators

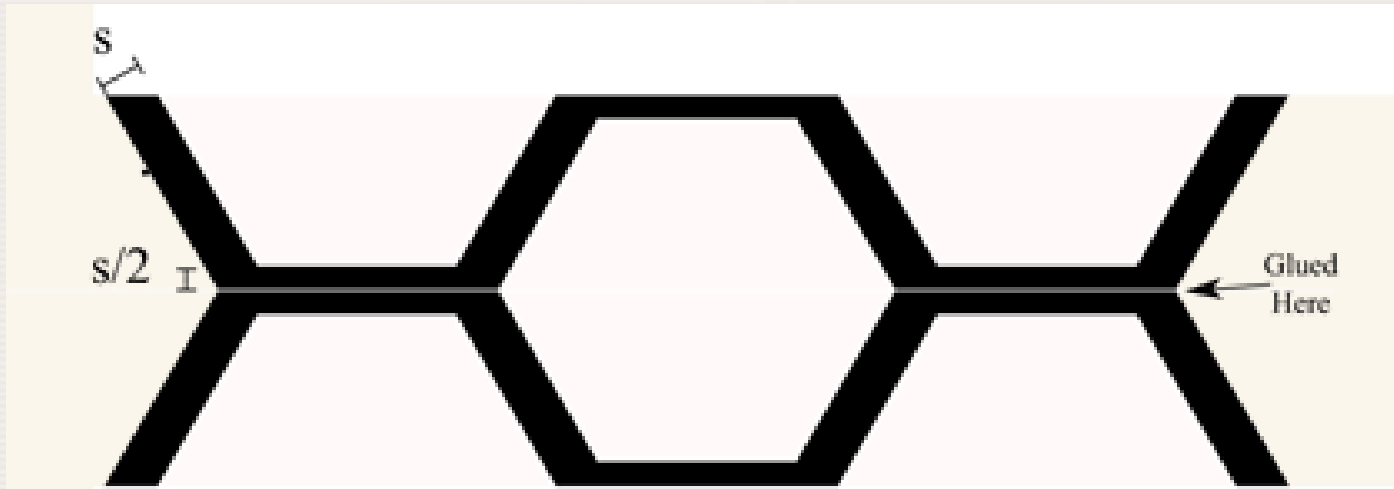

Fabrication of foil collimator by gluing two stamped lead foils. Careful alignment is essential to preserve the hole shapes.

11.2 GAMMA CAMERA SYSTEMS

11.2.2 The Anger camera

11.2.2.1 Collimators

Non-uniformities

- Non uniformities due to collimator defects are different for cast and foil collimators.
- Foil collimators can give stripes in the image, due to a defective manufacturing process.

11.2 GAMMA CAMERA SYSTEMS

11.2.2 The Anger camera

11.2.2.1 Collimators

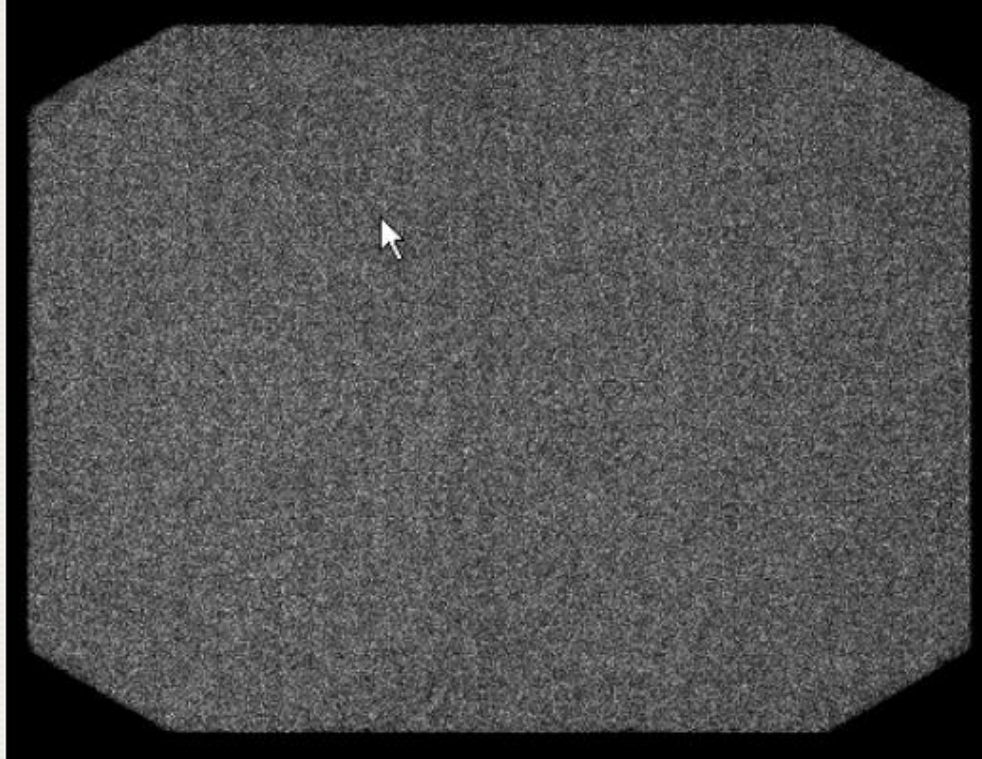

Uniformity image of a defective foil collimator. The vertical stripes in the image result from non-uniform sensitivity of the collimator due to problems in the manufacturing process

11.2 GAMMA CAMERA SYSTEMS

11.2.2 The Anger camera

11.2.2.1 Collimators

Hole geometries

Parallel

- The most frequent geometry, 1:1 ratio between object and image size

Converging

- Image magnification, used to image small organs

Diverging

- Used to image large objects in small field of view camera

Pinhole

- Focal point between image plane and object being imaged

11.2 GAMMA CAMERA SYSTEMS

11.2.2 The Anger camera

11.2.2.1 Collimators

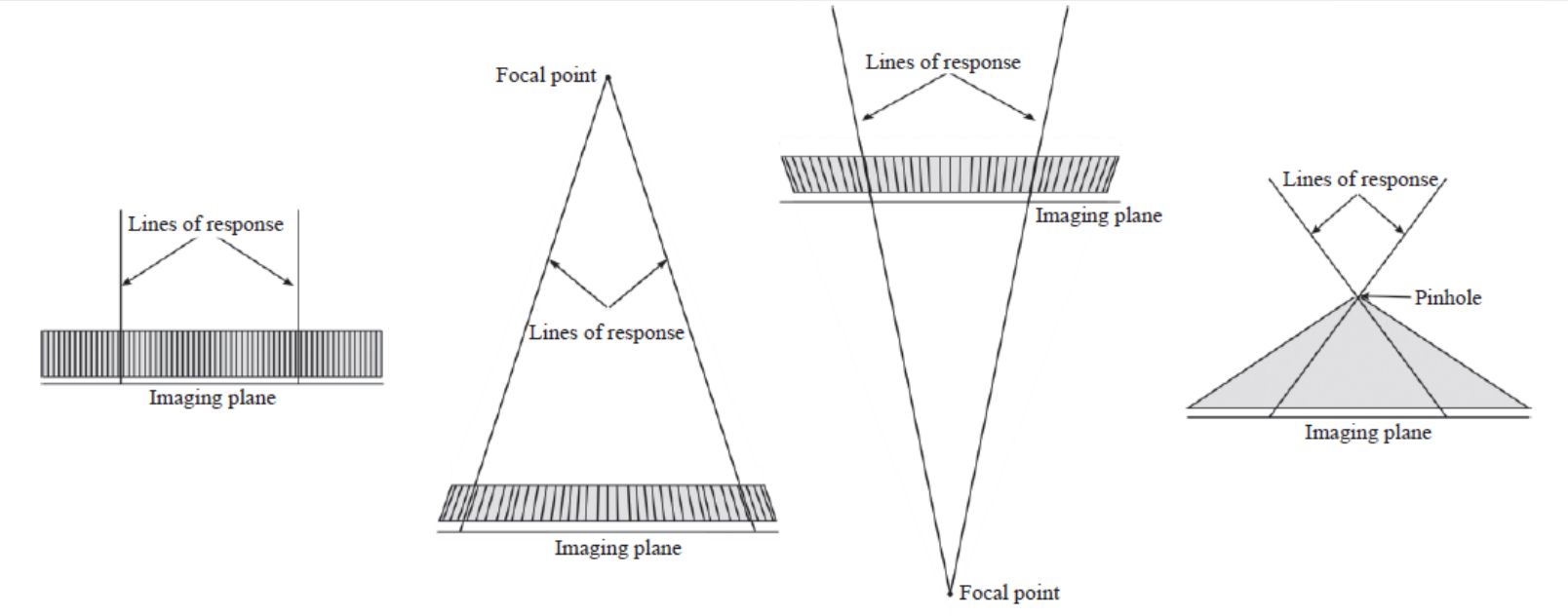

Four common collimator geometries: (left to right) parallel, converging, diverging and pinhole.

11.2 GAMMA CAMERA SYSTEMS

11.2.2 The Anger camera

11.2.2.1 Collimators

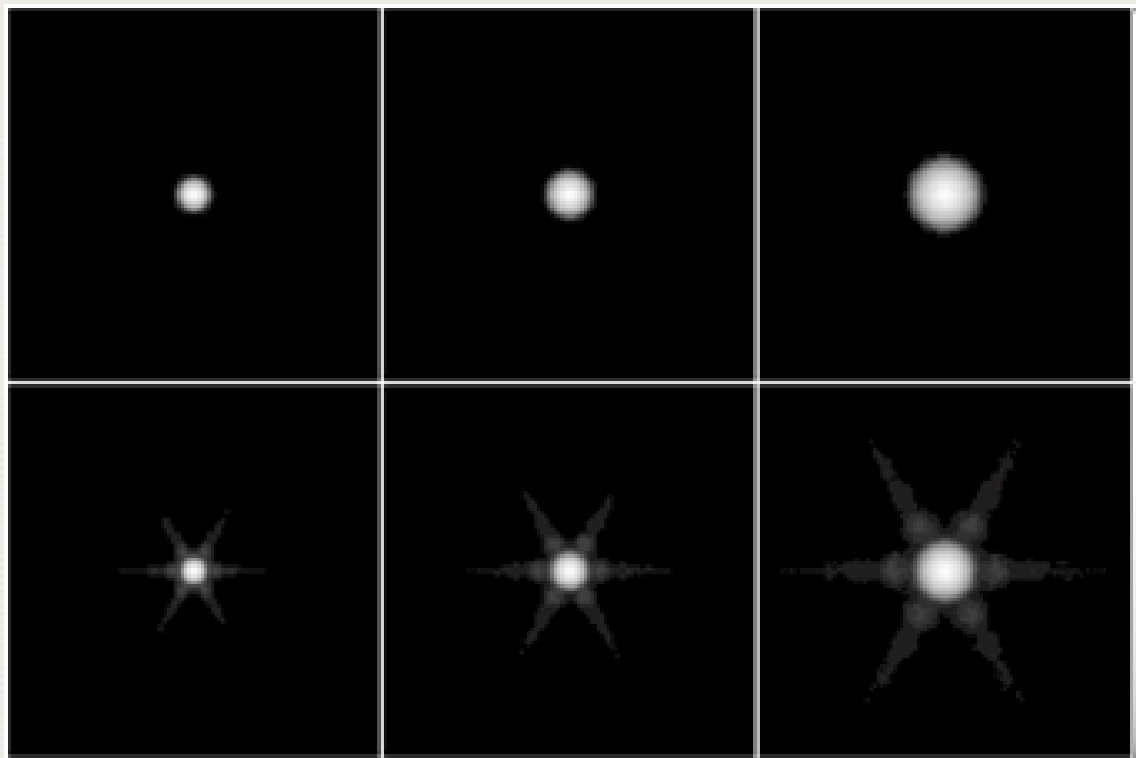

Sample images of the point spread function for a ^{131}I point source at (left to right) 5, 10 and 20 cm from the face of a high energy general purpose collimator (top row) and a medium energy general purpose collimator (bottom row), showing septal penetration and scatter effects in the latter.

11.2 GAMMA CAMERA SYSTEMS

11.2.2 The Anger camera

11.2.2.1 Collimators

Frequency response

- ❑ Another useful way to describe and understand the resolution properties of the collimator is in terms of its frequency response.
- ❑ This can be described by the collimator modulation transfer function (MTF), which is the magnitude of the Fourier transform of the collimator PSF.

11.2 GAMMA CAMERA SYSTEMS

11.2.2 The Anger camera

11.2.2.1 Collimators

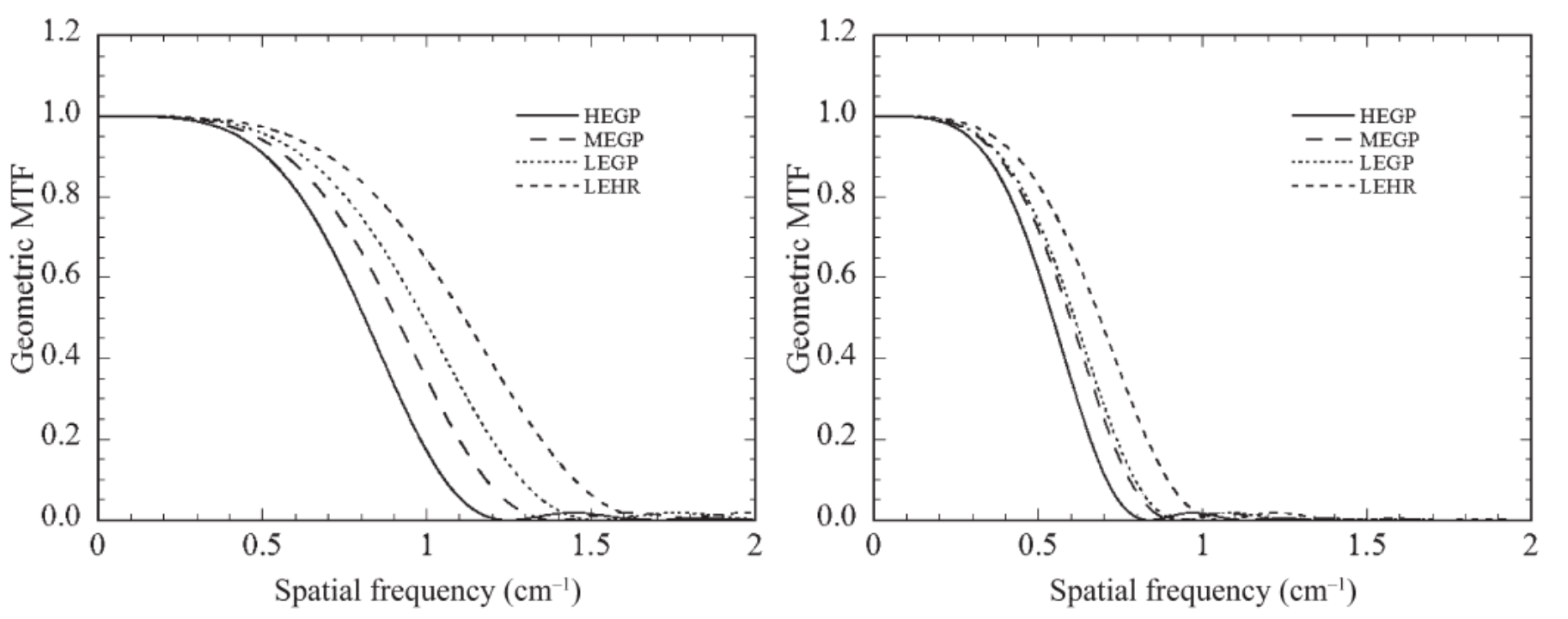

MTF profile for different collimators for sources at 5 cm (left) and 20 cm (right) from collimator face.



11.2 GAMMA CAMERA SYSTEMS

11.2.2 The Anger camera

11.2.2.1 Collimators

FWMH and FWTM

- ❑ It is often desirable to summarize the collimator resolution in terms of one or two numbers.
- ❑ This is often done in terms of the width of the collimator point spread response function (PSRF) at a certain fraction of its maximum value.
- ❑ Two values frequently used are the full width at half maximum (FWHM) and full width at tenth maximum (FWTM).

11.2 GAMMA CAMERA SYSTEMS

11.2.2 The Anger camera

11.2.2.1 Collimators

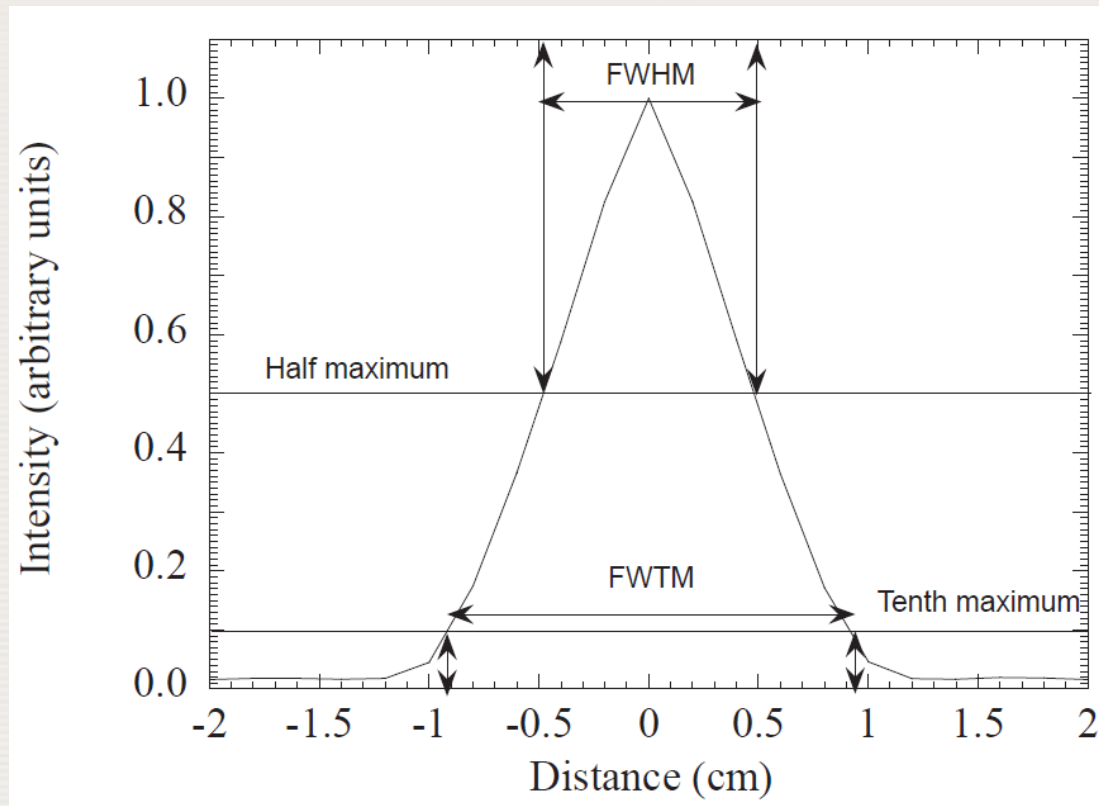

Plot of the total collimator–detector point spread function, indicating the positions of the full width at half maximum (FWHM) and full width at tenth maximum (FWTM).

11.2 GAMMA CAMERA SYSTEMS

11.2.2 The Anger camera

11.2.2.1 Collimators

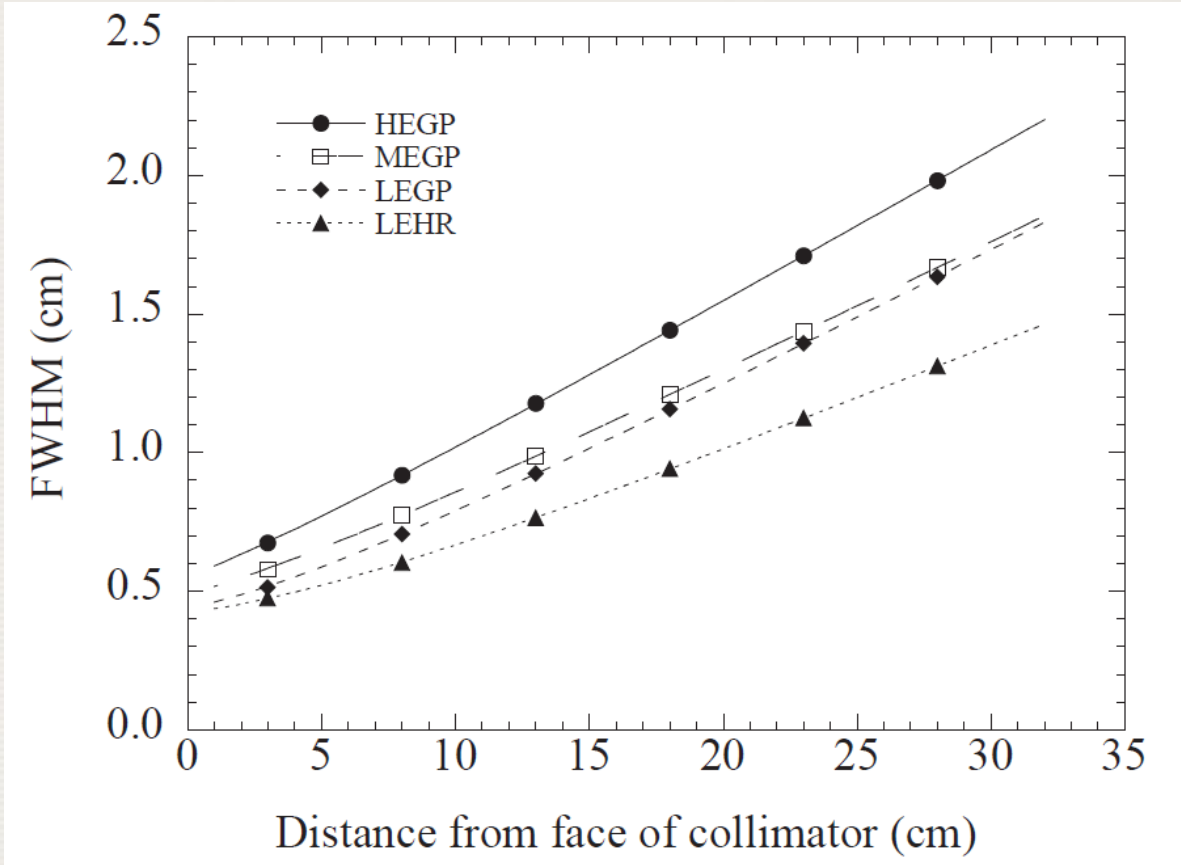

Distance from face of the collimator dependence of FWHM for different collimators



11.2 GAMMA CAMERA SYSTEMS

11.2.2 The Anger camera

11.2.2.1 Collimators

Collimator geometry used to derive the expression for the full width at half maximum.

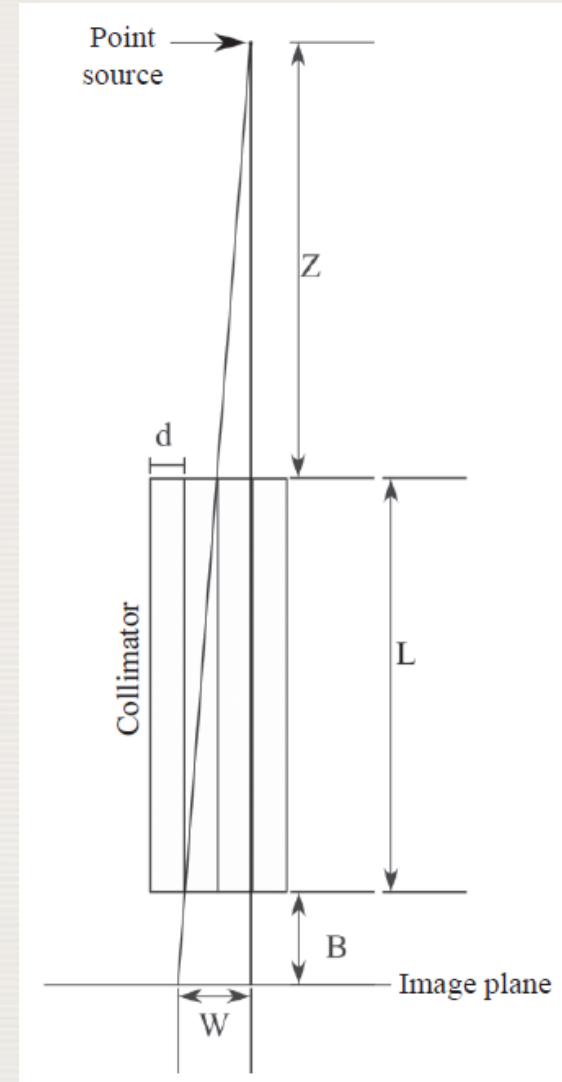

11.2 GAMMA CAMERA SYSTEMS

11.2.2 The Anger camera

11.2.2.2 Scintillation crystals

- ❑ The scintillation crystal in the gamma camera converts gamma ray photons incident on the crystal into a number of visible light photons.
- ❑ The crystals used in gamma cameras based on photomultiplier tubes (PMTs) are typically made of NaI(Tl).

11.2 GAMMA CAMERA SYSTEMS

11.2.2 The Anger camera

11.2.2.2 Scintillation crystals

Crystal thickness

- ❑ One important parameter of the scintillation crystal related to camera performance is its thickness.
- ❑ The thickness is a trade-off between two characteristics: intrinsic resolution and sensitivity.
- ❑ Thicker crystal have higher sensitivity and poorer resolution.

11.2 GAMMA CAMERA SYSTEMS

11.2.2 The Anger camera

11.2.2.2 Scintillation crystals

Intrinsic sensitivity

- The intrinsic sensitivity decreases with energy.
- For 140 keV, the sensitivity is 92% for a 0.953 cm (3/8 in) thick crystal (the most common crystal thickness in commercial systems).

11.2 GAMMA CAMERA SYSTEMS

11.2.2 The Anger camera

11.2.2.2 Scintillation crystals

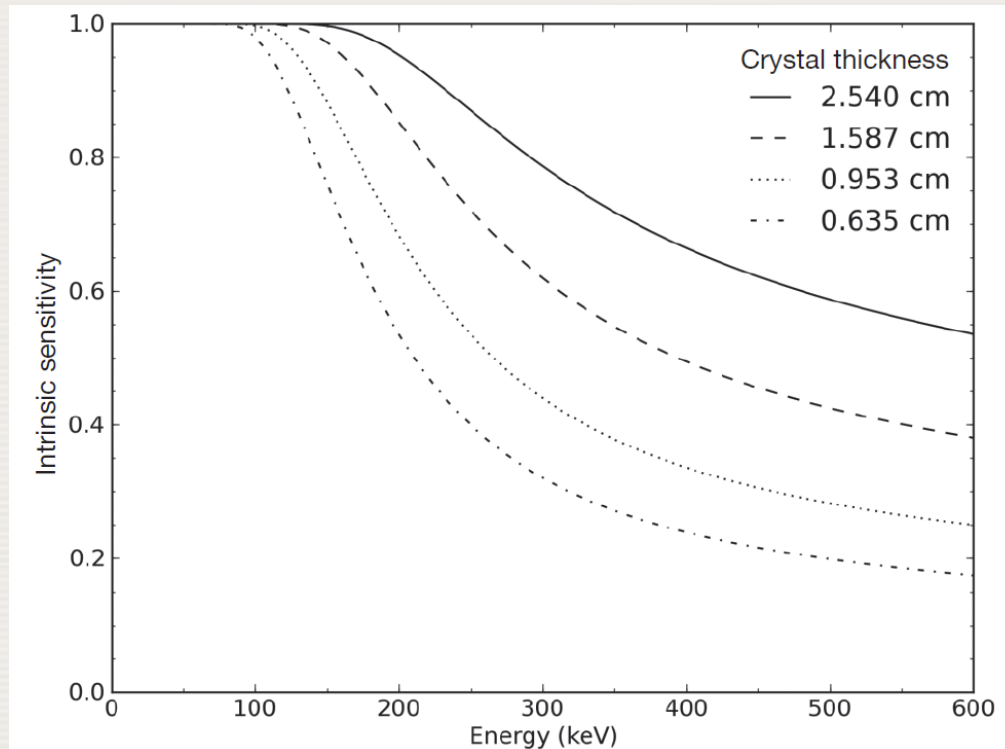

Intrinsic sensitivity of a NaI scintillation crystal as a function of energy for several crystal thicknesses

11.2 GAMMA CAMERA SYSTEMS

11.2.2 The Anger camera

11.2.2.3 Photodetector array

- ❑ It measures the distribution of scintillation photons incident on the array and converts it into a set of pulses whose charge is proportional to the number of scintillation photons incident on each corresponding element in the array.
- ❑ The photodetector array is comprised of a set of 30–90 PMTs arranged in a hexagonal close packed arrangement.
- ❑ In some applications, PMTs have been replaced by semiconductor detectors, but they are less sensitive and have lower gain than PMTs.

11.2 GAMMA CAMERA SYSTEMS

11.2.2 The Anger camera

11.2.2.3 Photodetector array

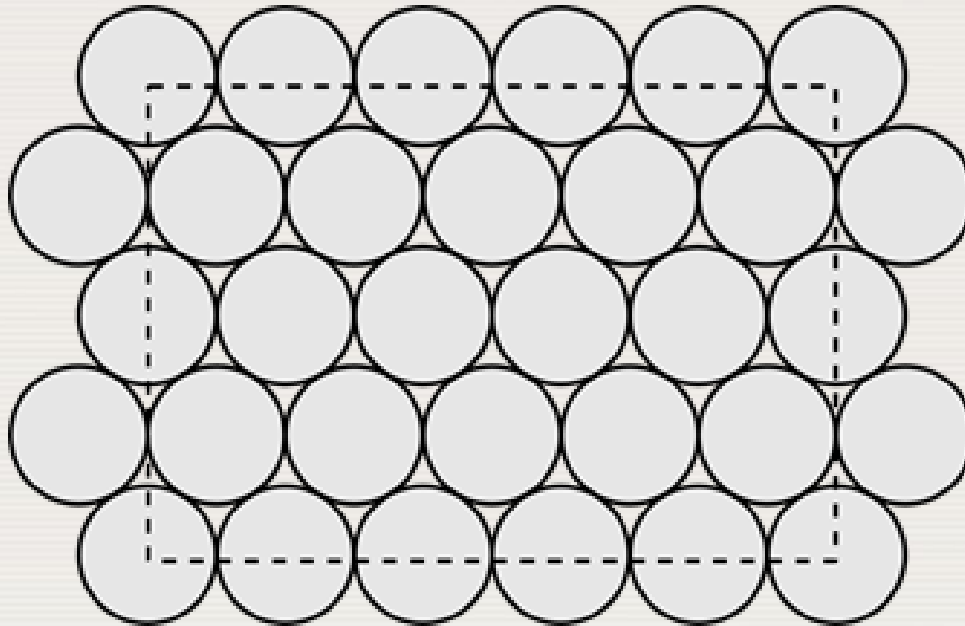

Hexagonal close packed array of photomultiplier tubes. The dotted line indicates the approximate region where useful images can be obtained.

11.2 GAMMA CAMERA SYSTEMS

11.2.2 The Anger camera

11.2.2.3 Photodetector array

- ❑ The position and energy are estimated from the set of charge signals from the elements in the photodetector array.
- ❑ In gamma cameras, a great reduction in cost and complexity is achieved, estimating the interaction position of the gamma ray based on the output of the array of PMTs.
- ❑ Thus, gain and temperature control , as well as adequate magnetic shielding must be guaranteed.

11.2 GAMMA CAMERA SYSTEMS

11.2.2 The Anger camera

11.2.2.3 Photodetector array

- ❑ Cross-section through two photomultiplier tubes (PMTs), the exit window and crystal in a gamma camera.
- ❑ The interaction position of a gamma ray photon is indicated.
- ❑ The solid angles subtended by photomultiplier tubes 1 and 2 are Ω_1 and Ω_2 , respectively.

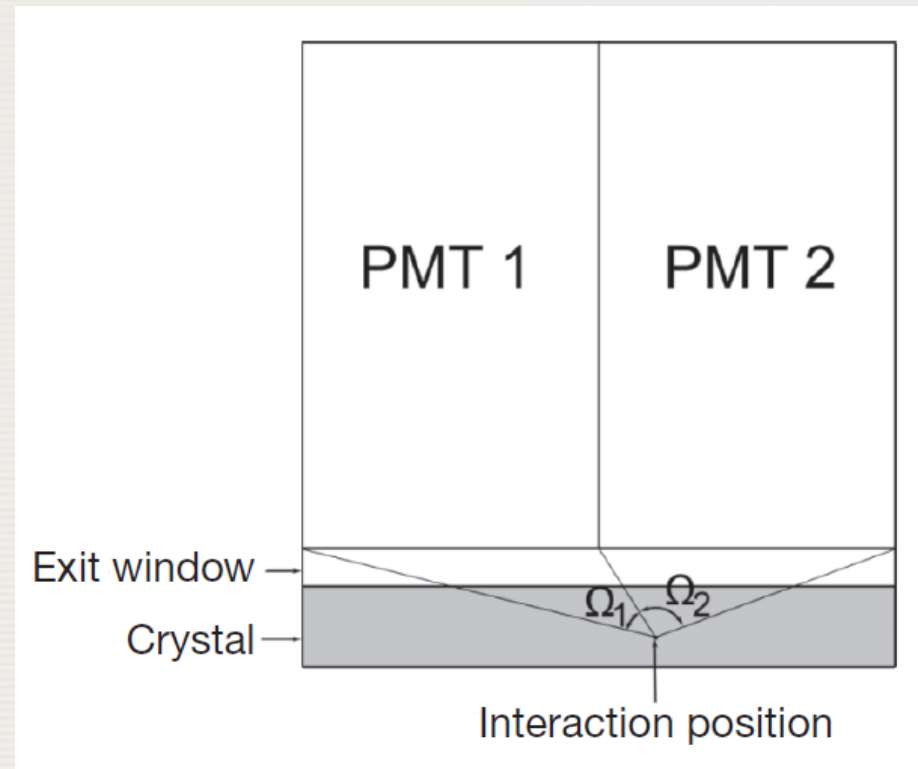

11.2 GAMMA CAMERA SYSTEMS

11.2.2 The Anger camera

11.2.2.4 Amplifiers and pulse shaping

- ❑ The charge pulse is amplified and shaped prior to processing to estimate the interaction position and photon energy.
- ❑ The components of this stage are a preamplifier and shaping amplifier, to produce near Gaussian pulses.
- ❑ More recent commercial gamma cameras have used digital pulse processing methods to perform this function.

11.2 GAMMA CAMERA SYSTEMS

11.2.2 The Anger camera

11.2.2.5 Position and energy estimation

- ❑ The goal of the radiation detector is to provide an estimate of the energy and interaction position of each gamma ray incident on the detector.
- ❑ The position and energy estimation circuits estimate the gamma ray energy and position from the set of voltage values from the photodetector array.

11.2 GAMMA CAMERA SYSTEMS

11.2.2 The Anger camera

11.2.2.5 Position and energy estimation

- The energy E can be computed using:

$$E = X_+ + X_- + Y_+ + Y_-$$

- The interaction position, defined by x and y can be computed using:

$$x = \frac{X_+ - X_-}{E} \quad \text{and} \quad y = \frac{Y_+ - Y_-}{E}$$

- In early gamma cameras, the computations above were performed using analogue circuits . In current systems, the computations are performed digitally.

11.2 GAMMA CAMERA SYSTEMS

11.2.2 The Anger camera

11.2.2.5 Position and energy estimation

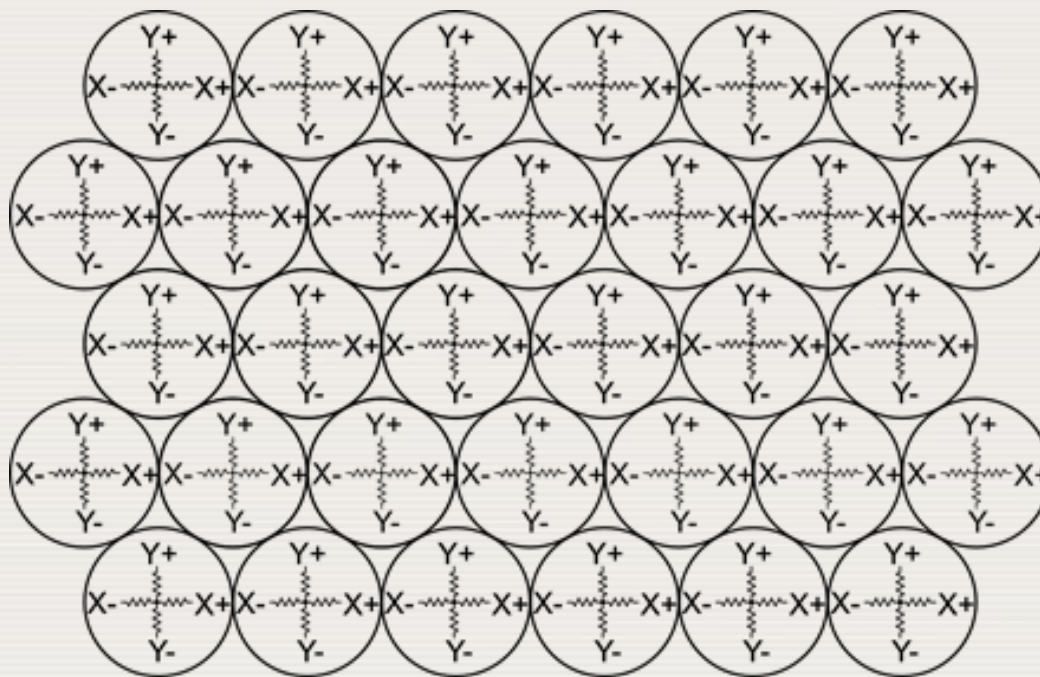

Resistive network used to implement position estimation. The output from each photomultiplier tube/preamplifier is divided by a resistive network with four outputs, X_+ , X_- , Y_+ and Y_- .

11.2 GAMMA CAMERA SYSTEMS

11.2.2 The Anger camera

11.2.2.5 Position and energy estimation

Problems of resistive summing and estimation approaches

- ❑ Light collected by phototubes is not linearly related to the distance from the interaction point.
- ❑ The distribution of light between two tubes changes more quickly when the interaction position lies between two tubes than it does when the interaction position is directly over a tube.
- ❑ It is not possible to reliably estimate the position of photons interacting near the edge of the camera.

11.2 GAMMA CAMERA SYSTEMS

11.2.2 The Anger camera

11.2.2.5 Position and energy estimation

- ❑ To a good approximation, both the energy and intrinsic spatial resolution can be characterized by a Gaussian function.
- ❑ Typical values of fractional energy resolution and intrinsic spatial resolution are approximately 9% and 3-5 mm respectively.

11.2 GAMMA CAMERA SYSTEMS

11.2.2 The Anger camera

11.2.2.6 Corrections

- To obtain clinically acceptable images, energy, spatial and uniformity corrections are needed.
- Without these corrections, substantial spatial non uniformities, edge packing artefacts near the edge of the FOV and visibility of tube pattern are noted.

11.2 GAMMA CAMERA SYSTEMS

11.2.2 The Anger camera

11.2.2.6 Corrections

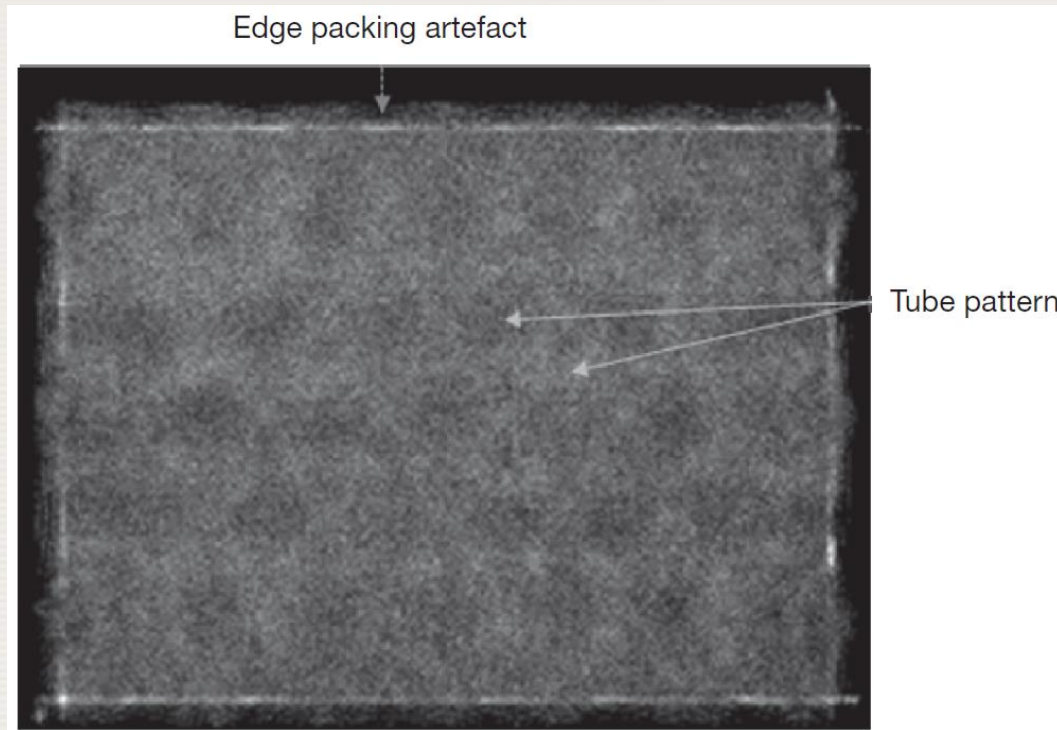

Intrinsic flood image of gamma camera without energy, spatial or sensitivity corrections.

11.2 GAMMA CAMERA SYSTEMS

11.2.2 The Anger camera

11.2.2.6 Corrections

Energy corrections

- ❑ Energy corrections are needed because the estimated energy depends on spatial position.
- ❑ A typical energy correction algorithm measures the energy spectrum as a function of position in the image using a source or sources with known energies.

11.2 GAMMA CAMERA SYSTEMS

11.2.2 The Anger camera

11.2.2.6 Corrections

Sample energy spectrum for 140 keV photons for the cases of :

- average,
- 2% lower than average
- 2% higher than average

light collection efficiency.

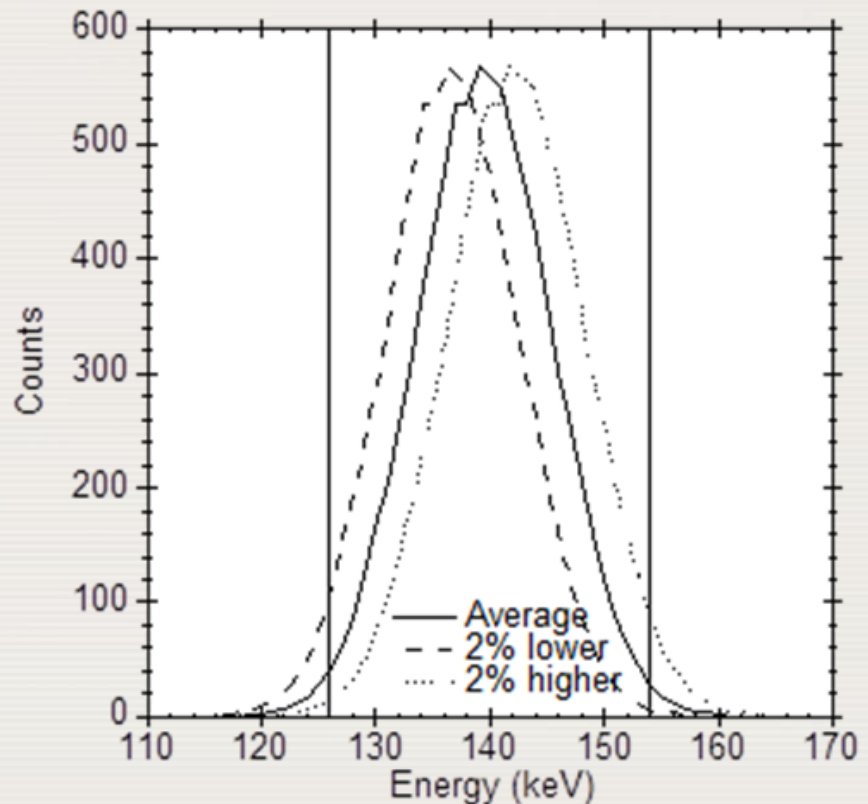

11.2 GAMMA CAMERA SYSTEMS

11.2.2 The Anger camera

11.2.2.6 Corrections

Spatial corrections

- ❑ Spatial corrections are needed because of biases in estimated interaction positions.
- ❑ These corrections involve imaging a mask with a grid of holes or lines in combination with a flood source.
- ❑ A function, typically a polynomial, is fit to the set of true points as a function of the set of measured points.

11.2 GAMMA CAMERA SYSTEMS

11.2.2 The Anger camera

11.2.2.6 Corrections

Uniformity corrections

- ❑ The final type of correction applied is a uniformity or sensitivity correction. The goal of this correction is to make images of a flood source as uniform as possible.
- ❑ Intrinsic flood images are usually acquired using a point (or syringe) source containing a small quantity of the isotope of interest.
- ❑ Extrinsic flood images are made using a flood or sheet source. Fillable flood sources have the advantage that they can be used for any isotope.

11.2 GAMMA CAMERA SYSTEMS

11.2.2 The Anger camera

11.2.2.6 Corrections

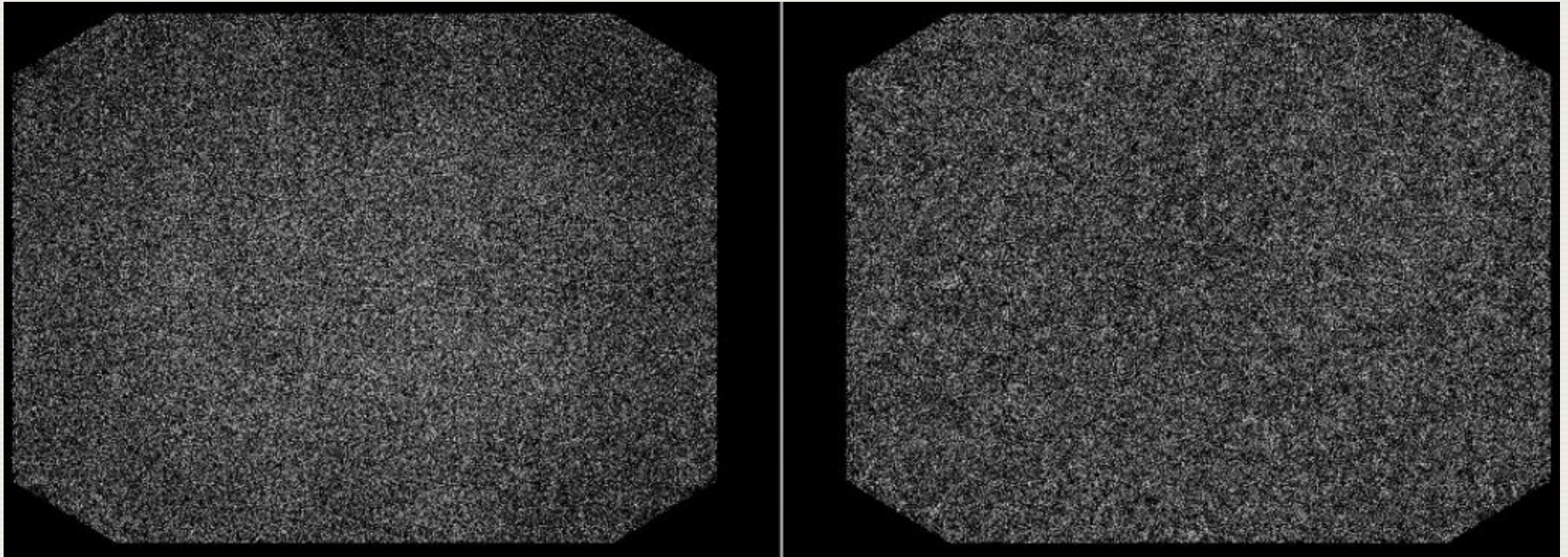

Intrinsic flood images for a gamma camera having a poor (left) and good (right) set of corrections applied

11.2 GAMMA CAMERA SYSTEMS

11.2.2 The Anger camera

11.2.2.7 Image framing

- ❑ Image framing refers to building spatial histograms of the counts as a function of position and possibly other variables.
- ❑ Position is mapped to the elements in a 2-D matrix of pixels.
- ❑ It depends, for a determined FOV, on the number of pixels, zoom factor and image offset.

11.2 GAMMA CAMERA SYSTEMS

11.2.2 The Anger camera

11.2.2.7 Image framing

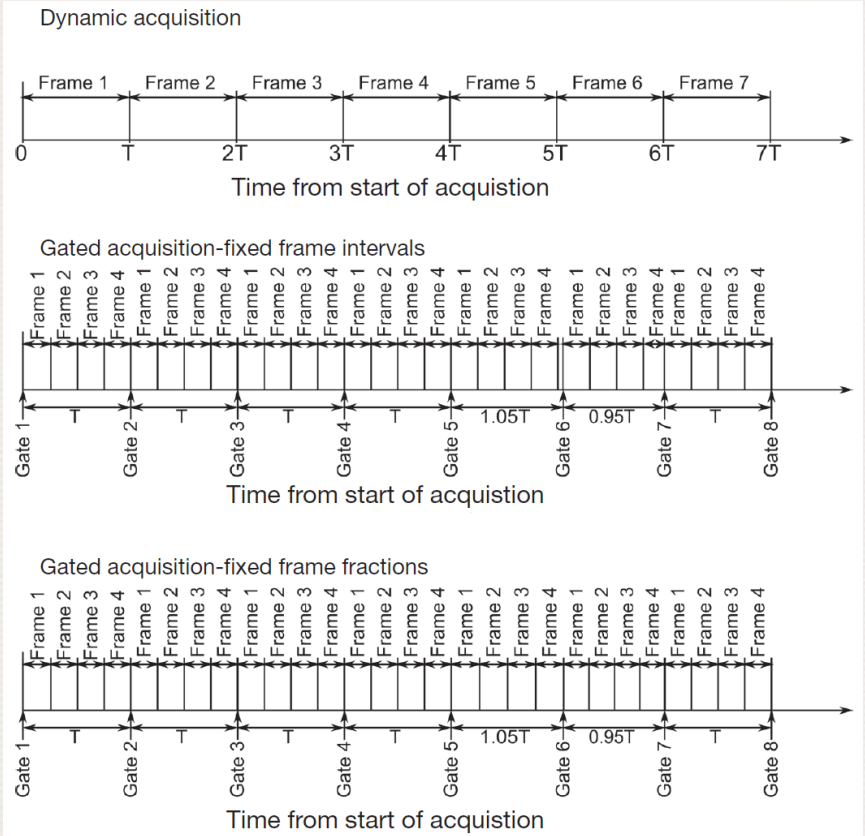

Comparison of dynamic and gated acquisition modes



11.2 GAMMA CAMERA SYSTEMS

11.2.2 The Anger camera

11.2.2.7 Image framing

In addition to adding counts to the appropriate pixel spatially, the framing algorithm performs a number of other important functions.

- ❑ The first is to reject photons that lie outside of the energy window of interest.
- ❑ Gamma cameras typically offer the ability to simultaneously frame images corresponding to more than one energy window.
- ❑ The ability to obtain a sequence of dynamic images.

11.2 GAMMA CAMERA SYSTEMS

11.2.2 The Anger camera

11.2.2.8 Camera housing

- ❑ Provides radiation shielding for the detectors and magnetic shielding for the PMTs.
- ❑ It incorporates a temperature control system, typically consisting of fans to circulate air and provide ventilation.
- ❑ It provides a mounting for the collimators, with touch and/or proximity sensors for patient safety and to protect the equipment.

11.2 GAMMA CAMERA SYSTEMS

11.2.3 SPECT systems

11.2 GAMMA CAMERA SYSTEMS

11.2.3 SPECT systems

11.2.3.1 Gamma camera single photon emission computed tomography systems (SPECT)

- ❑ SPECT is associated with hardware requirements that are beyond those needed for planar imaging.
- ❑ The most common implementation involves use of a conventional gamma camera in conjunction with a gantry that allows rotation of the entire detector head about the patient.

11.2 GAMMA CAMERA SYSTEMS

11.2.3 SPECT systems

11.2.3.1 Gamma camera single photon emission computed tomography systems

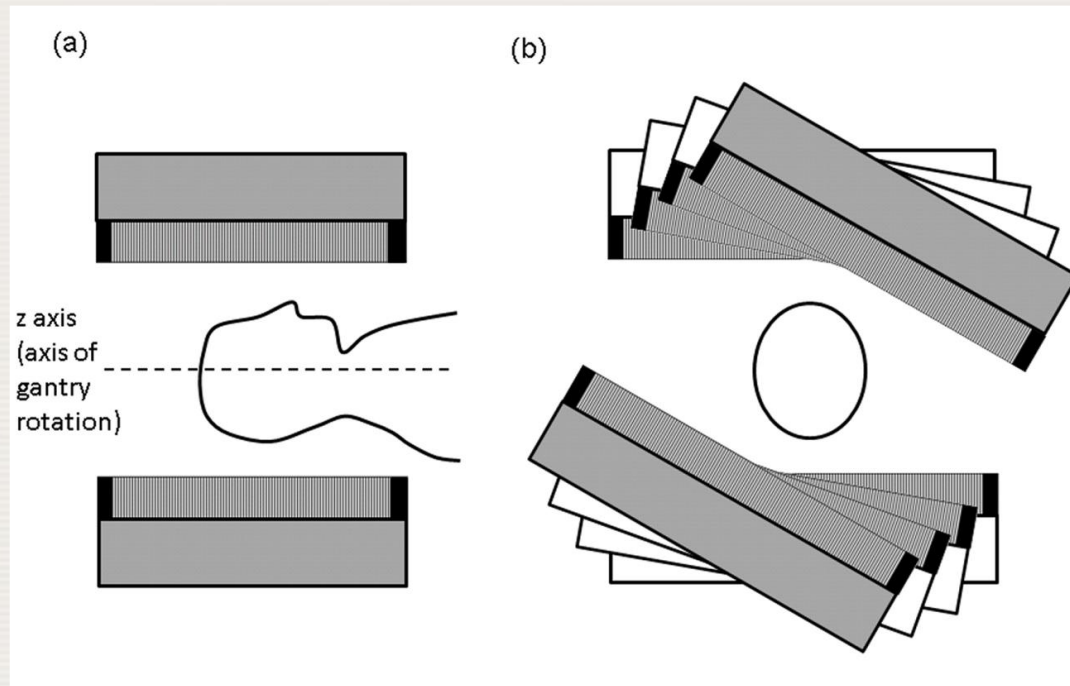

- (a) A cross-section of a dual head gamma camera capable of acquiring two views simultaneously.
(b) A transverse slice with the position of four different camera orientations superimposed.

11.2 GAMMA CAMERA SYSTEMS

11.2.3 SPECT systems

11.2.3.1 Gamma camera single photon emission computed tomography systems

- ❑ SPECT data are generally acquired over 360 degrees.
- ❑ Increasing the number of detector heads diminishes the time correspondingly. Dual head systems are the most frequent.
- ❑ Relative head orientation is variable according to purpose. 180 and 90 degrees are the most common configurations (for general purpose and cardiac imaging respectively).

11.2 GAMMA CAMERA SYSTEMS

11.2.3 SPECT systems

11.2.3.1 Gamma camera single photon emission computed tomography systems

- ❑ Detectors need to be correctly aligned.
- ❑ To identify and correct the alignment, an experimental center of rotation procedure is performed.
- ❑ A small point source is placed in the FOV at an off-centre location. SPECT data acquisition is performed and deviations from the expected sinusoidal pattern are measured in the resulting sinograms.

11.2 GAMMA CAMERA SYSTEMS

11.2.3 SPECT systems

11.2.3.1 Gamma camera single photon emission computed tomography systems

- (a) A series of planar views acquired at different angular orientations.
- (b) A sinogram corresponding to a particular axial location.

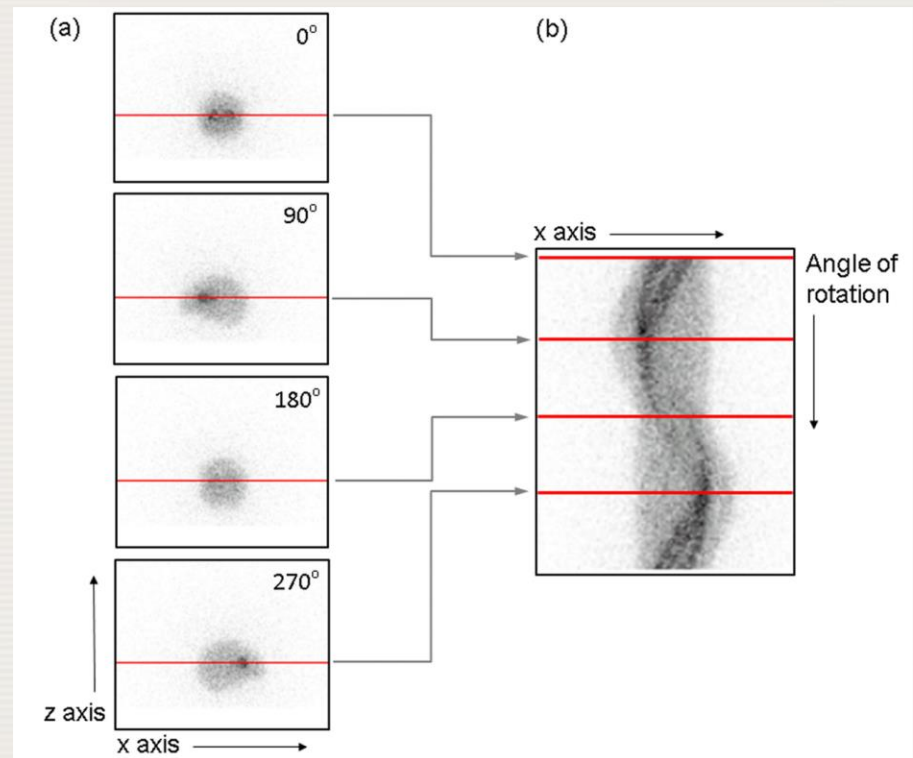

11.2 GAMMA CAMERA SYSTEMS

11.2.3 SPECT systems

11.2.3.1 Gamma camera single photon emission computed tomography systems

- ❑ The images acquired for each projection are corrupted by various factors.
- ❑ The most significant ones are photon attenuation, scatter and depth dependent collimator response.
- ❑ Software corrections are implemented to compensate these effects.

11.2 GAMMA CAMERA SYSTEMS

11.2.3 SPECT systems

11.2.3.2 Attenuation correction

- ❑ In SPECT, the interaction of photons via photoelectric absorption and Compton scatter within the patient results in attenuated projections.
- ❑ The attenuated projections can be described for the 2-D case by the equation:

$$P_{\theta}(t) = \int_0^{\infty} a(l\mathbf{n}_{\theta} + t\mathbf{m}_{\theta}) e^{-\int_0^l \mu(l'\mathbf{n}_{\theta} + t\mathbf{m}_{\theta}) dl'} dl$$

11.2 GAMMA CAMERA SYSTEMS

11.2.3 SPECT systems

11.2.3.2 Attenuation correction

Projection geometry used to describe the attenuated projection

- ❑ The projection is at an angle θ .
- ❑ A parallel-hole collimator is assumed.
- ❑ The unit vector \mathbf{n}_θ is perpendicular to the collimator and parallel to the projection rays.
- ❑ The unit vector \mathbf{m}_θ is parallel to the collimator face and perpendicular to \mathbf{n}_θ .
- ❑ The variable t is the distance along the detector from the projected position of the origin.

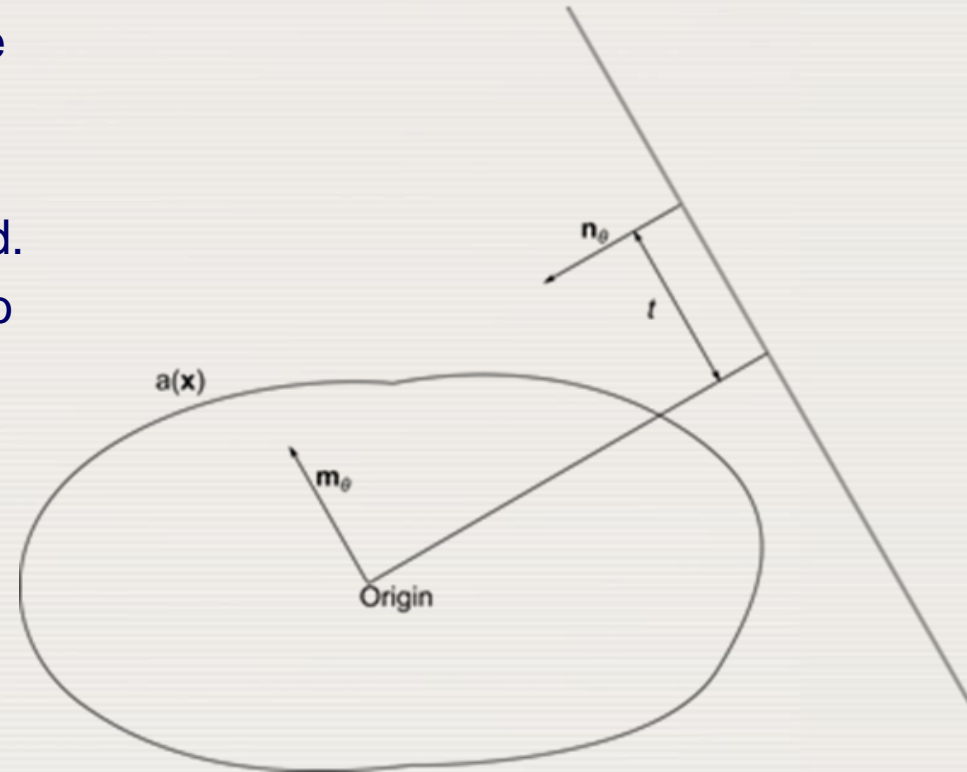

11.2 GAMMA CAMERA SYSTEMS

11.2.3 SPECT systems

11.2.3.2 Attenuation correction

- ❑ To compensate for attenuation, we can either assume:
 - uniform attenuation inside the object and extract information about the body outline from the emission data, or
 - use a direct transmission measurement.
- ❑ A number of commercial devices have been developed to allow measurement of the attenuation distribution in the body, using either radionuclide or X ray sources to obtain transmission images.

11.2 GAMMA CAMERA SYSTEMS

11.2.3 SPECT systems

11.2.3.2 Attenuation correction

- The intensity $I_\theta(t)$ passing through the body for a source with incident intensity I_0 , projection position t and projection view θ is given by:

$$I_\theta(t) = I_0(t) e^{-\int_0^\infty \mu(l\mathbf{n}_\theta + t\mathbf{m}_\theta) dl}$$

- Acquiring sets of these transmission data for various angles allows reconstruction of the attenuation distribution.

11.2 GAMMA CAMERA SYSTEMS

11.2.3 SPECT systems

11.2.3.2 Attenuation correction

Transmission devices based on radionuclide sources

- ❑ A number of transmission devices based on radionuclide sources have been developed and marketed. All of these devices use the gamma camera to detect the transmission photons.
- ❑ Typically, ^{153}Gd is used as it has an energy lower than that of $^{99\text{m}}\text{Tc}$ and the transmission photons, thus, do not interfere with collection of emission data.

11.2 GAMMA CAMERA SYSTEMS

11.2.3 SPECT systems

11.2.3.2 Attenuation correction

Types of radionuclide sources

- Sheet sources
- Line sources
 - Single line
 - Scanning line source
 - Stationary line source
 - Multiple lines
- Point sources

11.2 GAMMA CAMERA SYSTEMS

11.2.3 SPECT systems

11.2.3.2 Attenuation correction

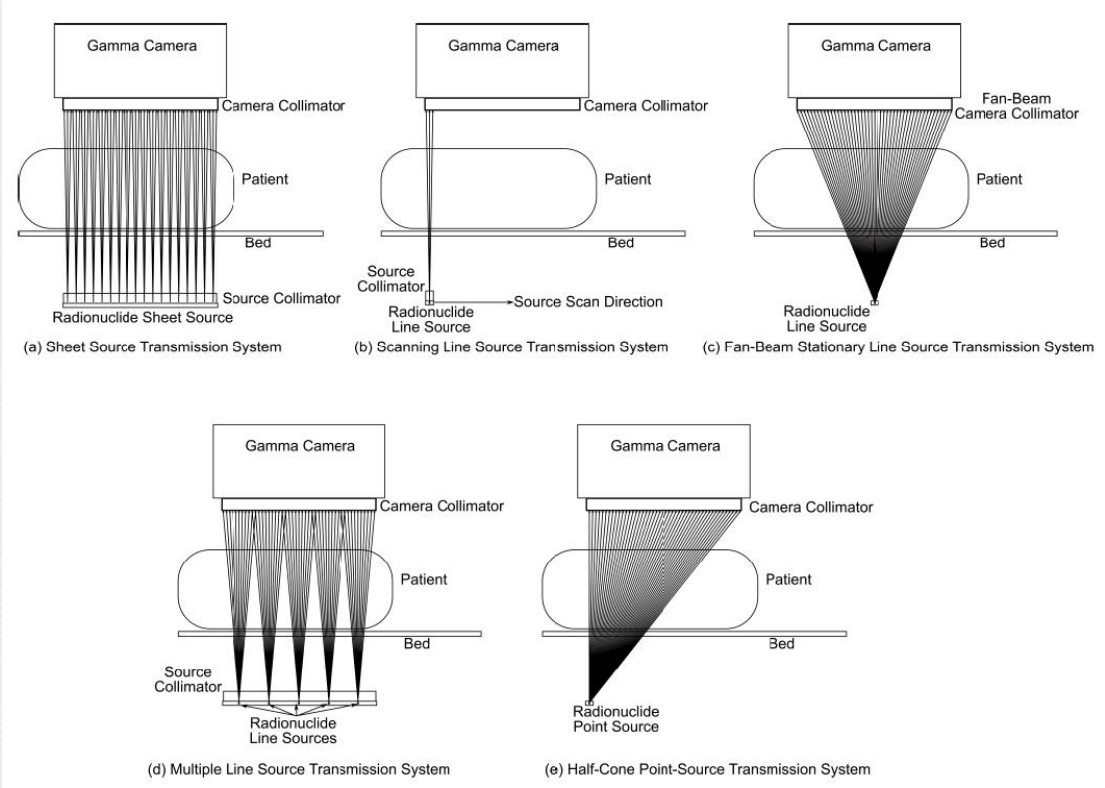

Different transmission scanning devices using radionuclide sources.



11.2 GAMMA CAMERA SYSTEMS

11.2.3 SPECT systems

11.2.3.2 Attenuation correction

Disadvantages of radionuclide transmission sources

- The source decays and must be replaced.
- Limits on transmission count rates imposed by the gamma camera.

11.2 GAMMA CAMERA SYSTEMS

11.2.3 SPECT systems

11.2.3.2 Attenuation correction

Disadvantages of radionuclide transmission sources (cont.)

- ❑ If the emission activity within the patient is high, the transmission images can be degraded, resulting in inaccurate attenuation maps.
- ❑ The resolution of the transmission scan is limited by the combination of source and camera collimator.

In general, these provide lower resolution transmission scans.

11.2 GAMMA CAMERA SYSTEMS

11.2.3 SPECT systems

11.2.3.2 Attenuation correction

Advantages of radionuclide transmission sources

- ❑ The potential to perform simultaneous imaging, thus eliminating the need for an additional transmission scan.
- ❑ Registration of the emission and transmission images is guaranteed, especially when acquired simultaneously.
- ❑ Converting the transmission images into an attenuation map at the energy of the emission source is easier than for X ray CT based systems.

11.2 GAMMA CAMERA SYSTEMS

11.2.3 SPECT systems

11.2.3.2 Attenuation correction

Transmission devices based on X ray sources

- Slow rotation
- Hybrid SPECT-CT systems

11.2 GAMMA CAMERA SYSTEMS

11.2.3 SPECT systems

11.2.3.2 Attenuation correction

Disadvantages of X ray based methods

- ❑ The image is not acquired simultaneously and is often acquired with the bed in a different position than used for the SPECT scan and thus, the potential for mis-registration of the SPECT images and attenuation maps.
- ❑ The effects of motion, especially respiratory motion, during the attenuation scan are different to those during the emission scan.
- ❑ Transmission data are acquired using a polychromatic source.



11.2 GAMMA CAMERA SYSTEMS

11.2.3 SPECT systems

11.2.3.2 Attenuation correction

Advantages of X ray based methods

- Higher acquisition speed.
- Better quality of the attenuation maps (high resolution and low noise).
- The convenience of not needing to replace radionuclide sources (cost and time benefits).

They have largely replaced devices based on radionuclide sources due to their advantages.

11.2 GAMMA CAMERA SYSTEMS

11.2.3 SPECT systems

11.2.3.2 Attenuation correction

Transformation of Hounsfield units to attenuation map
(piecewise linear scaling)

$$\mu(h) = \begin{cases} \frac{1000 + h}{1000} \mu_{\text{water}} & \text{for } h \leq 0 \\ \mu_{\text{water}} + \frac{h}{h_{\text{bone}}} (\mu_{\text{bone}} - \mu_{\text{water}}) & \text{for } 0 < h < h_{\text{bone}} \\ \frac{h}{h_{\text{bone}}} \mu_{\text{bone}} & \text{for } h > h_{\text{bone}} \end{cases}$$

μ_{water} and μ_{bone} are the attenuation coefficients of water and bone, respectively.

11.2 GAMMA CAMERA SYSTEMS

11.2.3 SPECT systems

11.2.3.2 Attenuation correction

Reconstruction methods

- ❑ Once the attenuation map is obtained, attenuation correction can be implemented using analytical, approximate or statistical image reconstruction algorithms.
- ❑ Generally, analytical methods are not used due to their poor noise properties.
- ❑ For the best attenuation compensation, statistical iterative reconstruction methods should be used.

11.2 GAMMA CAMERA SYSTEMS

11.2.3 SPECT systems

11.2.3.3 Scatter correction

- ❑ A significant fraction of the detected photons are scattered in the body.
- ❑ The scatter to primary ratio (SPR) varies significantly according to the study (0.2 for brain imaging, 0.6 for cardiac imaging).
- ❑ Scatter results in loss of contrast and loss of quantitative accuracy.

11.2 GAMMA CAMERA SYSTEMS

11.2.3 SPECT systems

11.2.3.3 Scatter correction

- ❑ Scatter correction requires both estimating the scatter component of the projection data combined with a compensation method.
- ❑ Most frequently, the scatter component is estimated using data acquired in auxiliary energy windows.
- ❑ One simple method is the triple energy window (TEW) method. This method uses two scatter energy windows, one above and one below the photopeak window.

11.2 GAMMA CAMERA SYSTEMS

11.2.3 SPECT systems

11.2.3.3 Scatter correction

- Use of a trapezoidal approximation to estimate the scatter in the photopeak energy window in the triple energy window method scatter compensation for ^{99m}Tc .
- For the case of ^{99m}Tc , the counts in the upper window are often assumed to be zero.

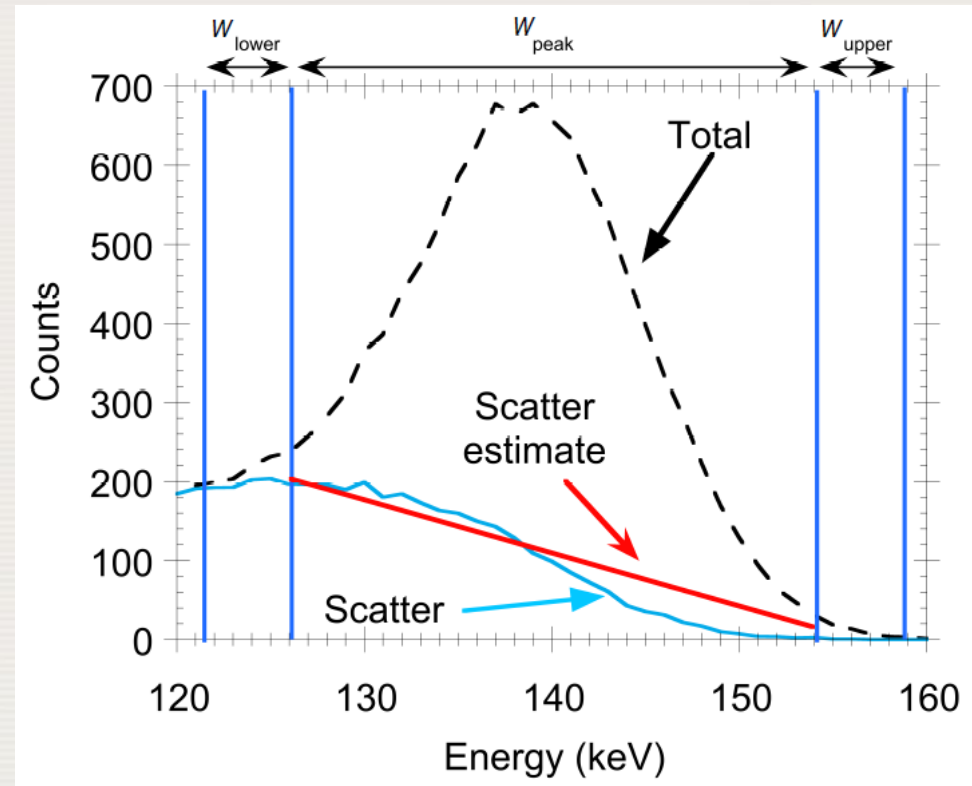

11.2 GAMMA CAMERA SYSTEMS

11.2.3 SPECT systems

11.2.3.3 Scatter correction

Scatter estimation

The estimated scatter counts in the photopeak window estimated using TEW s_{TEW} are given by:

$$s_{\text{TEW}} = \left[\frac{c_{\text{lower}}}{w_{\text{lower}}} + \frac{c_{\text{upper}}}{w_{\text{upper}}} \right] \frac{w_{\text{peak}}}{2}$$

where c_{lower} and c_{upper} are the counts in the lower and upper scatter windows, respectively; and w_{peak} , w_{lower} and w_{upper} are the widths of the photopeak, lower scatter and upper scatter windows, respectively.

11.2 GAMMA CAMERA SYSTEMS

11.2.3 SPECT systems

11.2.3.3 Scatter correction

Scatter estimation

- ❑ Another method to estimate the scatter component in the projection data is via the use of scatter modelling techniques.
- ❑ The mathematical techniques used range from accurate approximations to full Monte Carlo simulations.

11.2 GAMMA CAMERA SYSTEMS

11.2.3 SPECT systems

11.2.3.3 Scatter correction

Scatter compensation

- ❑ Scatter compensation can be accomplished by subtracting the scatter estimate from the projection data.
- ❑ For SPECT, a better way to accomplish scatter compensation is to add the scatter estimate to the computed projection during the iterative reconstruction process.
- ❑ Another approach is to include scatter modelling in the projection matrix.

11.2 GAMMA CAMERA SYSTEMS

11.2.3 SPECT systems

11.2.3.3 Collimator response compensation

- ❑ Images obtained with a gamma camera are degraded by the spatially varying collimator–detector response.
- ❑ Since SPECT images contain information about the distance from the source to the collimator, it is possible to provide improved compensation for the CDR as compared to planar imaging.
- ❑ This can be accomplished using both analytical and iterative methods.

11.2 GAMMA CAMERA SYSTEMS

11.2.3 SPECT systems

11.2.3.3 Collimator response compensation

- ❑ Collimator-detector response (CDR) compensation does not fully recover the loss of resolution of the collimator: the resolution remains limited and spatially varying and partial volume effects are still significant for small objects.
- ❑ Despite its limitations, CDR compensation has generally been shown to improve image quality for both detection and quantitative tasks.

11.3 POSITRON EMISSION TOMOGRAPHY SYSTEMS

11.3.1 Principle of annihilation coincidence detection

11.3 POSITRON EMISSION TOMOGRAPHY SYSTEMS

11.3.1 Principle of annihilation coincidence detection

- ❑ Positron emission and annihilation, with the emission of two photons 180 degrees apart, is the basis of PET image formation.
- ❑ PET does not require a collimator and, therefore, eliminates the weakest link in the SPECT image formation process. Coincidence detection is used to distinguish photons arising from positron annihilation, based on temporal discrimination.
- ❑ These facts makes PET more advantageous than SPECT, in terms of spatial resolution, statistical quality and quantitative accuracy.

11.3 POSITRON EMISSION TOMOGRAPHY SYSTEMS

11.3.1 Principle of annihilation coincidence detection

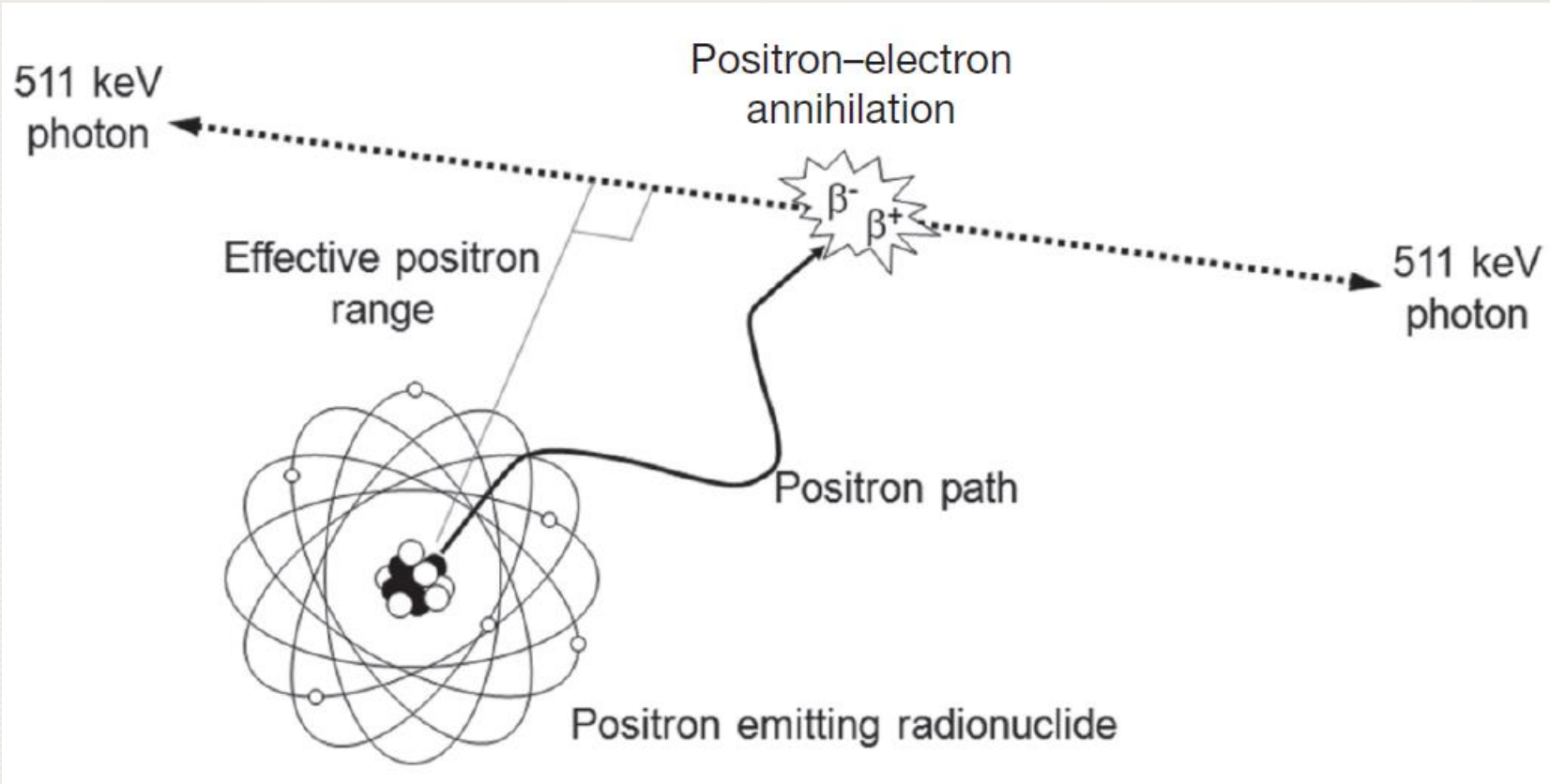

Positron decay and photon emission

11.3 POSITRON EMISSION TOMOGRAPHY SYSTEMS

11.3.1 Principle of annihilation coincidence detection

- ❑ If a positron source is surrounded by suitable detectors, both back to back photons from an individual positron decay can potentially be detected.
- ❑ A line drawn between corresponding detectors can be assumed to intersect the point of photon emission, although information is usually not available about exactly where along that line the emission occurred.
- ❑ A system of detectors arranged at different positions around the source permits multiple coincidence events to be recorded at different angular orientations.

11.3 POSITRON EMISSION TOMOGRAPHY SYSTEMS

11.3.1 Principle of annihilation coincidence detection

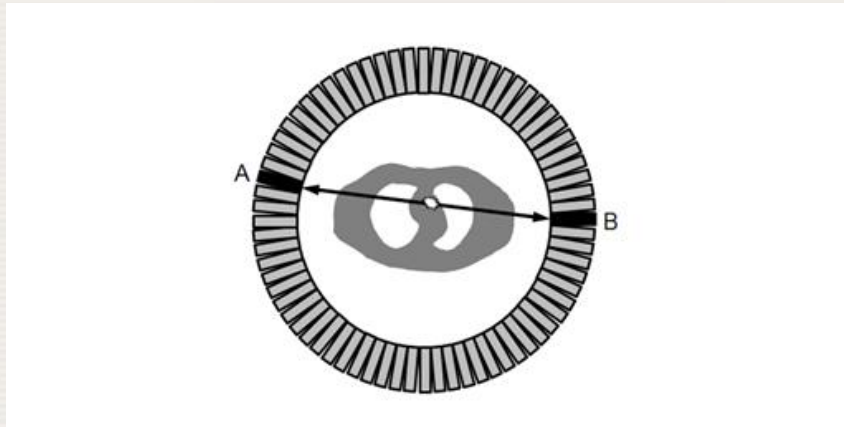

Coincidence detection involves the association of detection events occurring at two opposing detectors (A and B) based upon the arrival times of the two photons. A line of response joining the two detectors is assumed to intersect the unknown location of the annihilation event.

11.3 POSITRON EMISSION TOMOGRAPHY SYSTEMS

11.3.1 Principle of annihilation coincidence detection

Angular projections

- ❑ Angular projections of the activity distribution can be estimated from the coincidence events recorded.
- ❑ These projections may be used to reconstruct 3-D images using the methods of CT.

11.3 POSITRON EMISSION TOMOGRAPHY SYSTEMS

11.3.2 Design considerations for PET systems

11.3 POSITRON EMISSION TOMOGRAPHY SYSTEMS

11.3.2 Design considerations for PET systems

11.3.2.1 Spatial resolution

- ❑ The trend in modern scanner systems has been to decrease the width of individual detectors and to increase the total number of detector elements surrounding the patient.
- ❑ Problems can occur when photons are incident on one detector but penetrate through to an adjacent detector.
- ❑ It gives rise to a loss of resolution at more peripheral locations.
- ❑ This resolution loss generally occurs in the radial direction as opposed to the tangential direction due to the angle of incidence of the photons on the detectors.

11.3 POSITRON EMISSION TOMOGRAPHY SYSTEMS

11.3.2 Design considerations for PET systems

11.3.2.1 Spatial resolution

(a) Photon penetration between adjacent detectors in a ring based system leads to mispositioning of events.

(b) Residual momentum of the positron and electron immediately before annihilation causes the two photons to deviate slightly from the expected 180° angle.

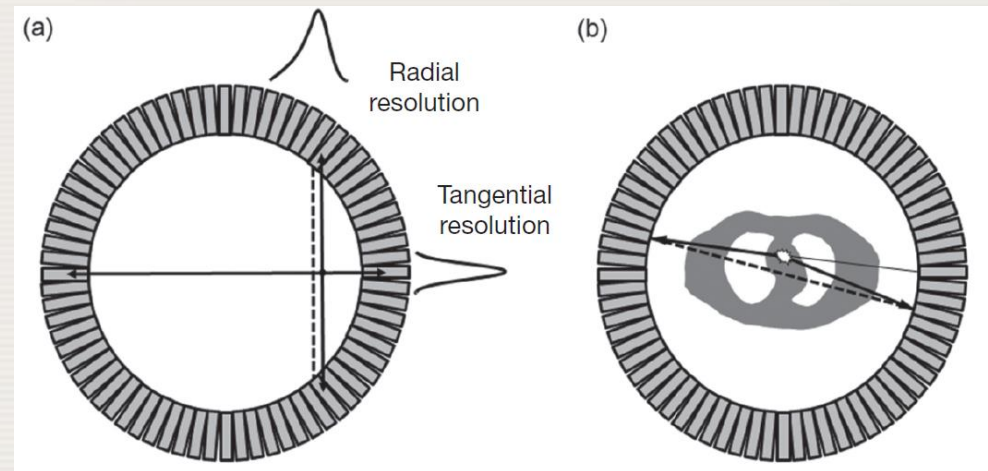

11.3 POSITRON EMISSION TOMOGRAPHY SYSTEMS

11.3.2 Design considerations for PET systems

11.3.2.1 Spatial resolution

- ❑ The non-collinearity effect tends to degrade spatial resolution as detector separation increases.
- ❑ For whole body systems, with opposing detectors separated 80 cm, a blurring of approximately 2 mm occurs for the FWHM.
- ❑ Another source of resolution loss is the positron range, which depends on the tissue the positron passes through and its energy.

11.3 POSITRON EMISSION TOMOGRAPHY SYSTEMS

11.3.2 Design considerations for PET systems

11.3.2.2 Sensitivity

High sensitivity is an important objective for scanner design due to limitations in:

- the amount of time a patient remains motionless.
- the amount of radioactive tracer administered.

11.3 POSITRON EMISSION TOMOGRAPHY SYSTEMS

11.3.2 Design considerations for PET systems

11.3.2.2 Sensitivity

Sensitivity variables

- ❑ Sensitivity is determined by
 - the geometry of the detector arrangement.
 - the absorption efficiency of the detectors themselves.
- ❑ Small ring diameters increase sensitivity, but the requirement to accommodate patients of various sizes imposes a minimum ring diameter.

11.3 POSITRON EMISSION TOMOGRAPHY SYSTEMS

11.3.2 Design considerations for PET systems

11.3.2.2 Sensitivity

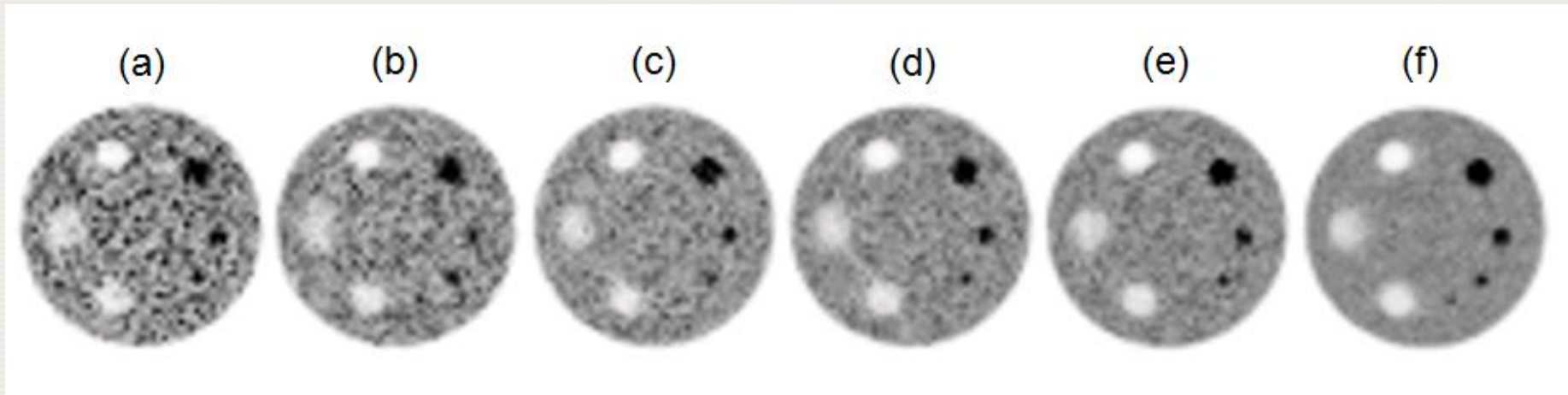

Images of the same phantom, each showing different statistical quality. The images shown in (a), (b), (c), (d), (e) and (f) were acquired for 1, 2, 3, 4, 5 and 20 min, respectively.

11.3 POSITRON EMISSION TOMOGRAPHY SYSTEMS

11.3.2 Design considerations for PET systems

11.3.2.2 Sensitivity

Absorption efficiency

- A high absorption efficiency for 511 keV photons is desirable in order to make best use of those photons that are incident upon the detectors.
- Absorption efficiency or stopping power of the detector material is, therefore, an important consideration for PET system design.

11.3 POSITRON EMISSION TOMOGRAPHY SYSTEMS

11.3.2 Design considerations for PET systems

11.3.2.3 Quantitative accuracy

- ❑ One of the strengths of PET is its capability to quantify physiological processes in vivo.
- ❑ Quantitative error can arise due to:
 - random coincidence events
 - photon scatter within the body
 - photon attenuation within the body
 - detector dead time.

11.3 POSITRON EMISSION TOMOGRAPHY SYSTEMS

11.3.2 Design considerations for PET systems

11.3.2.3 Quantitative accuracy

True coincidence

A true coincidence event (a) can occur when both photons escape the body without interacting.

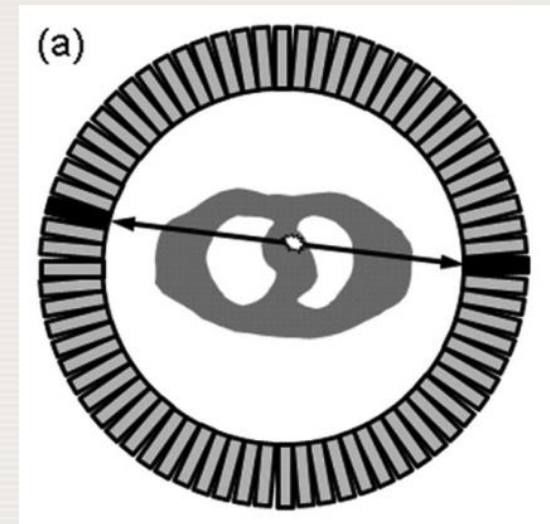

11.3 POSITRON EMISSION TOMOGRAPHY SYSTEMS

11.3.2 Design considerations for PET systems

11.3.2.3 Quantitative accuracy

Random coincidence

A random coincidence event (b) occurs when two photons from unrelated annihilation events are detected at approximately the same time.

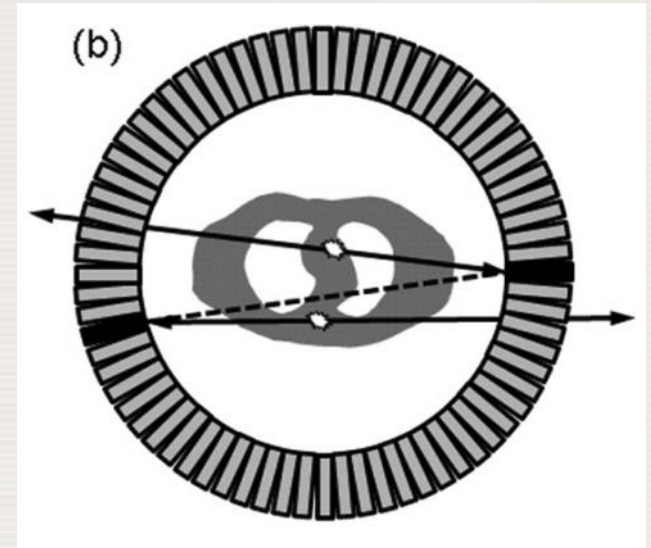

11.3 POSITRON EMISSION TOMOGRAPHY SYSTEMS

11.3.2 Design considerations for PET systems

11.3.2.3 Quantitative accuracy

Scattered coincidence

A scattered coincidence event (c) can occur when either photon is scattered within the body but is still detected.

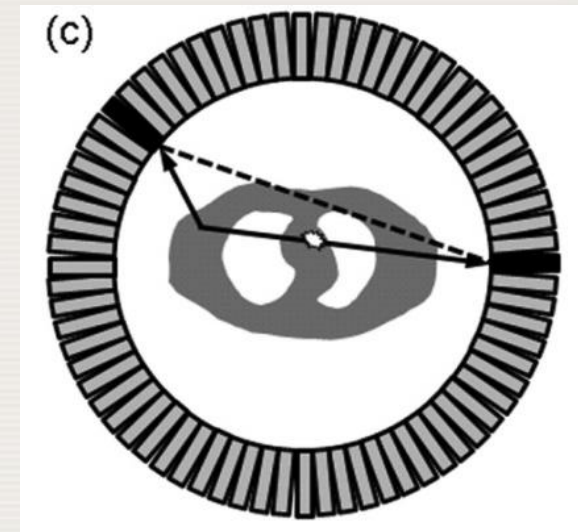

11.3 POSITRON EMISSION TOMOGRAPHY SYSTEMS

11.3.2 Design considerations for PET systems

11.3.2.3 Quantitative accuracy

No coincidence

No coincidence event (d) is recorded when one or both photons are attenuated, typically due to scatter out of the field.

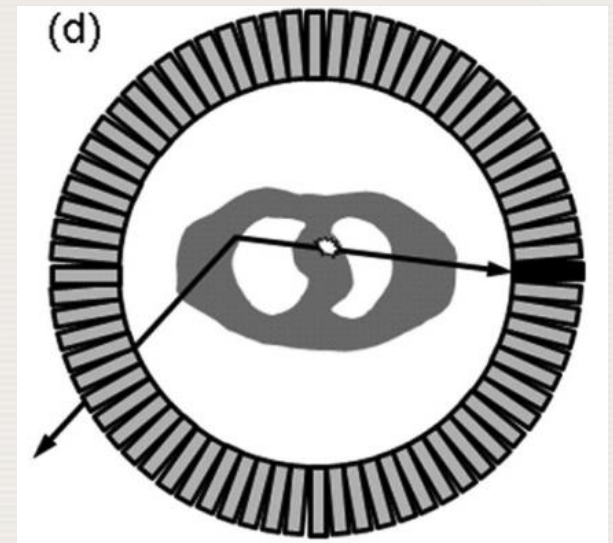

11.3 POSITRON EMISSION TOMOGRAPHY SYSTEMS

11.3.2 Design considerations for PET systems

11.3.2.3 Quantitative accuracy

PET systems should be designed to minimize the contribution of the various degrading factors shown below:

- Attenuation
- Scatter
- Random coincidence events

11.3 POSITRON EMISSION TOMOGRAPHY SYSTEMS

11.3.2 Design considerations for PET systems

11.3.2.3 Quantitative accuracy

Attenuated photons

- ❑ Very little can be done to reduce attenuation as photons that are absorbed within the body do not reach the detectors.

11.3 POSITRON EMISSION TOMOGRAPHY SYSTEMS

11.3.2 Design considerations for PET systems

11.3.2.3 Quantitative accuracy

Scattered photons

- ❑ Scattered photons can potentially be rejected by the detection system if their energy falls outside a predetermined acceptance range.

11.3 POSITRON EMISSION TOMOGRAPHY SYSTEMS

11.3.2 Design considerations for PET systems

11.3.2.3 Quantitative accuracy

Random events

- Decreasing the coincidence timing window decreases the number of random events.

11.3 POSITRON EMISSION TOMOGRAPHY SYSTEMS

11.3.2 Design considerations for PET systems

11.3.2.4 Other design considerations

The overall cost of the system is important for designers.

- The choice of detector material, the thickness of the detectors, the diameter of the detector ring and the axial extent of the detectors all contribute to the total cost of the system.
- The optimal CT configuration included in a combined system is limited mainly by cost concerns.
- Computer workstation for acquisition and processing.

11.3 POSITRON EMISSION TOMOGRAPHY SYSTEMS

11.3.3 Detector systems

11.3 POSITRON EMISSION TOMOGRAPHY SYSTEMS

11.3.3 Detector systems

11.3.3.1 Radiation detectors

Detectors used

- Almost all current systems adopt an approach based on scintillation detectors.
- Various scintillators have been used in PET: NaI(Tl), BGO and LSO.

11.3 POSITRON EMISSION TOMOGRAPHY SYSTEMS

11.3.3 Detector systems

11.3.3.1 Radiation detectors

The properties of an ideal crystal for PET would include

- high stopping power for 511 keV photons.
- short scintillation light decay time to reduce dead time and random coincidences.
- high light output.

11.3 POSITRON EMISSION TOMOGRAPHY SYSTEMS

11.3.3 Detector systems

11.3.3.1 Radiation detectors

(a) and (b) Bismuth germanate samples photographed under room lighting.

(c) In the presence of X ray irradiation and dimmed room lighting.

The scintillation light seen in (c) is due to the interaction of radiation with the crystals, which causes electrons to become excited. When they return to their ground state, energy is emitted, partly in the form of visible light.

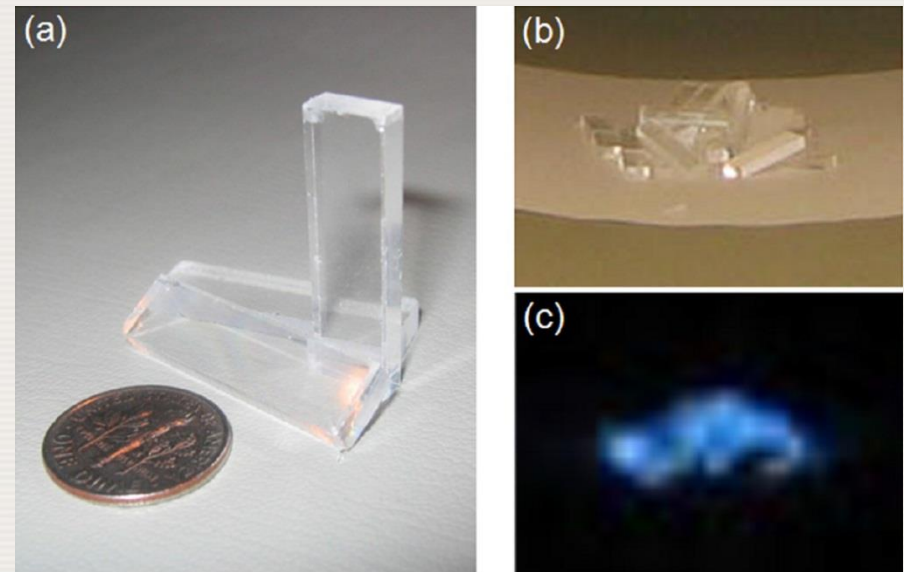

11.3 POSITRON EMISSION TOMOGRAPHY SYSTEMS

11.3.3 Detector systems

11.3.3.1 Radiation detectors

PROPERTIES OF SOME OF THE SCINTILLATORS USED IN PET.

Property	NaI	BGO	LSO
Linear attenuation coefficient (cm^{-1})	0.34	0.95	0.87
Scintillation decay constant (ns)	230	300	40
Relative light output	100%	15%	75%
Energy resolution (%)	6.6	10.2	10.0

Note: Linear attenuation coefficients and energy resolution are quoted for 511 keV

11.3 POSITRON EMISSION TOMOGRAPHY SYSTEMS

11.3.3 Detector systems

11.3.3.1 Radiation detectors

NaI(Tl) scintillator

- Although NaI(Tl) is ideal for lower energy single photon imaging, its relatively low linear attenuation coefficient for 511 keV photons makes it less attractive for PET applications.

11.3 POSITRON EMISSION TOMOGRAPHY SYSTEMS

11.3.3 Detector systems

11.3.3.1 Radiation detectors

BGO and LSO scintillators

- ❑ BGO and, more recently, LSO have replaced NaI(Tl) as the scintillator of choice for PET.
- ❑ BGO is well suited for scanner designs that minimize scatter and count rate via physical collimation (2D).
- ❑ LSO has become the scintillator of choice for scanner designs that operate without interplane septa (3D) because of its short decay time.

11.3 POSITRON EMISSION TOMOGRAPHY SYSTEMS

11.3.3 Detector systems

11.3.3.2 Detector arrangements

Use of photomultipliers (PMTs)

- ❑ For most PET applications, PMTs have been the preferred photodetector because their high gain results in an electrical output with a good signal to noise ratio.
- ❑ PMTs are often not used in combined PET/MR systems where space is limited and operation in high magnetic fields is a requirement.
- ❑ in these applications, the semiconductor device is used in conjunction with a scintillation detector.

11.3 POSITRON EMISSION TOMOGRAPHY SYSTEMS

11.3.3 Detector systems

11.3.3.2 Detector arrangements

Block detectors

- ❑ A PET detector block consists of scintillator material coupled to an array of photomultiplier tubes.
- ❑ The scintillator is cut into an array of individual crystal elements.
- ❑ Four photomultiplier tubes are typically used to read out the signal from an 8×8 array of crystal elements.

11.3 POSITRON EMISSION TOMOGRAPHY SYSTEMS

11.3.3 Detector systems

11.3.3.2 Detector arrangements

Principle of operation of a block detector:

The x and y position of each photon is determined from the signal measured by each of the four photomultiplier tubes labelled A–D, using the equations shown in the figure.

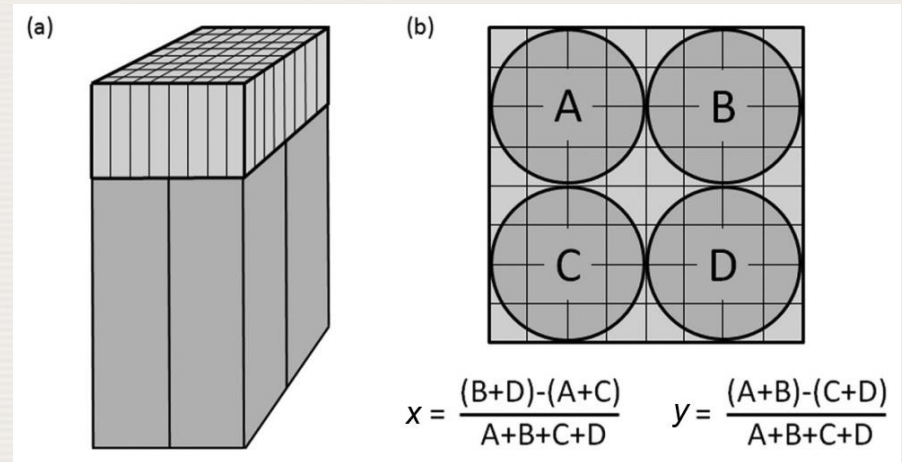

11.3 POSITRON EMISSION TOMOGRAPHY SYSTEMS

11.3.3 Detector systems

11.3.3.2 Detector arrangements

- ❑ One of the advantages of the block design is that each block operates independently of its surrounding blocks.
- ❑ An alternative arrangement, referred to as quadrant sharing, increases the encoding ratio by locating the PMTs at the corners of adjacent blocks.
- ❑ Another alternative to the block design adopts an approach similar to that used in conventional gamma cameras.

11.3 POSITRON EMISSION TOMOGRAPHY SYSTEMS

11.3.3 Detector systems

11.3.3.3 Scanner configurations

- ❑ Various scanner configurations have been developed, although the dominant design consists of a ring of detectors that completely surrounds the patient (or research subject) in one plane.
- ❑ Several rings of detectors are arranged in a cylindrical geometry, allowing multiple transverse slices to be simultaneously acquired.
- ❑ The diameter of the detector ring varies considerably between designs, reflecting the intended research or clinical application.

11.3 POSITRON EMISSION TOMOGRAPHY SYSTEMS

11.3.3 Detector systems

11.3.3.3 Scanner configurations

Full ring PET system (a) shown in the transverse plane, indicating how each detector can form coincidence events with a specific number of detectors on the opposite side of the ring.

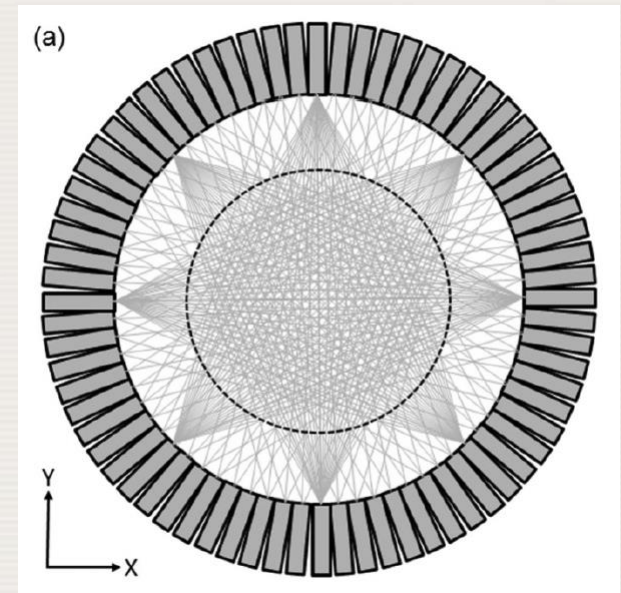

11.3 POSITRON EMISSION TOMOGRAPHY SYSTEMS

11.3.3 Detector systems

11.3.3.3 Scanner configurations

PET system shown in side elevation (b), indicating the limited detector coverage in the z direction.

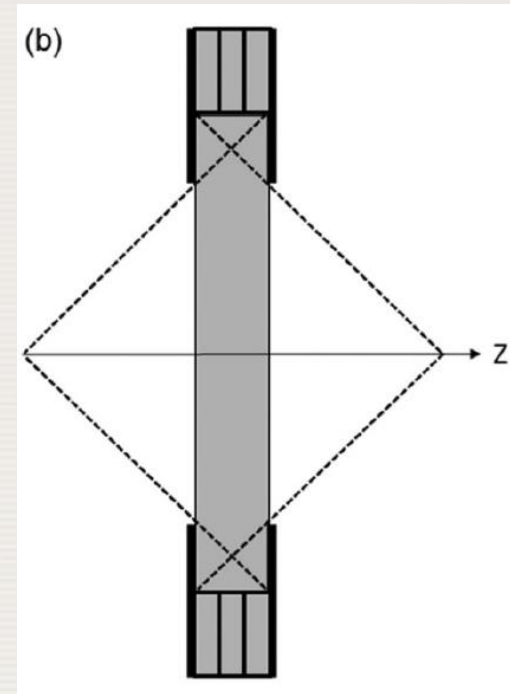

11.3 POSITRON EMISSION TOMOGRAPHY SYSTEMS

11.3.3 Detector systems

11.3.3.3 Scanner configurations

- ❑ Full ring PET systems simultaneously acquire all projections required for tomographic image formation.
- ❑ This has an obvious advantage in terms of sensitivity, and it also enables short acquisition times, which can be important for dynamic studies.
- ❑ The use of dual head gamma cameras operating in coincidence for PET has been discontinued, due to its poor performance.

11.3 POSITRON EMISSION TOMOGRAPHY SYSTEMS

11.3.4 Data acquisition

11.3 POSITRON EMISSION TOMOGRAPHY SYSTEMS

11.3.4 Data acquisition

11.3.4.1 Coincidence processing

- ❑ The basis of coincidence detection is that pairs of related 511 keV annihilation photons can be associated together by the detector system based upon their times of measurement.
- ❑ The time interval determining when events are considered to be coincident is denoted 2τ .
- ❑ For BGO it is around 12 ns. Shorter time windows can be used with LSO.

11.3 POSITRON EMISSION TOMOGRAPHY SYSTEMS

11.3.4 Data acquisition

11.3.4.1 Coincidence processing

Photons detected at A and B produce signals that are amplified and analysed to determine whether they meet the energy acceptance criteria.

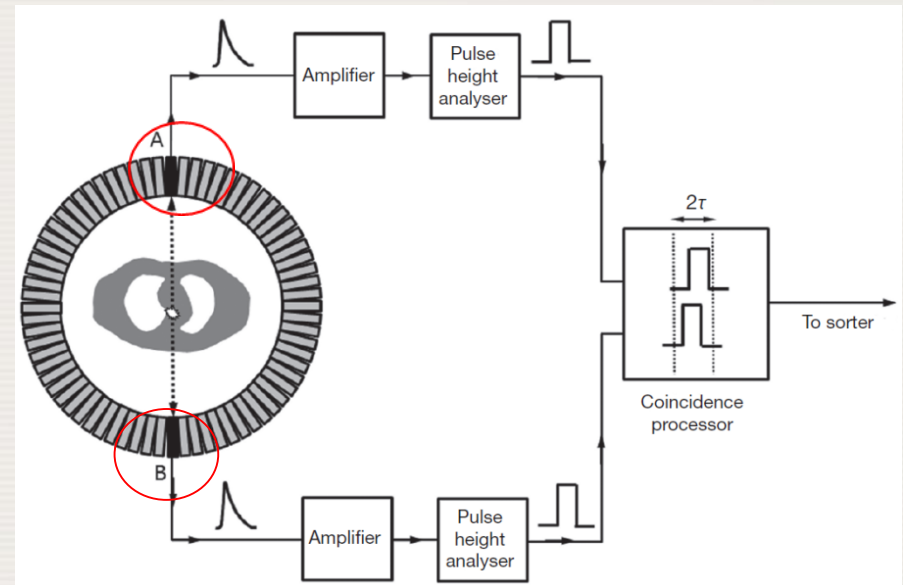

11.3 POSITRON EMISSION TOMOGRAPHY SYSTEMS

11.3.4 Data acquisition

11.3.4.1 Coincidence processing

Those signals that fall within the energy acceptance window produce a logic pulse (width τ) that is passed to the coincidence processor. A coincidence event is indicated if both logic pulses fall within a specified interval (2τ)

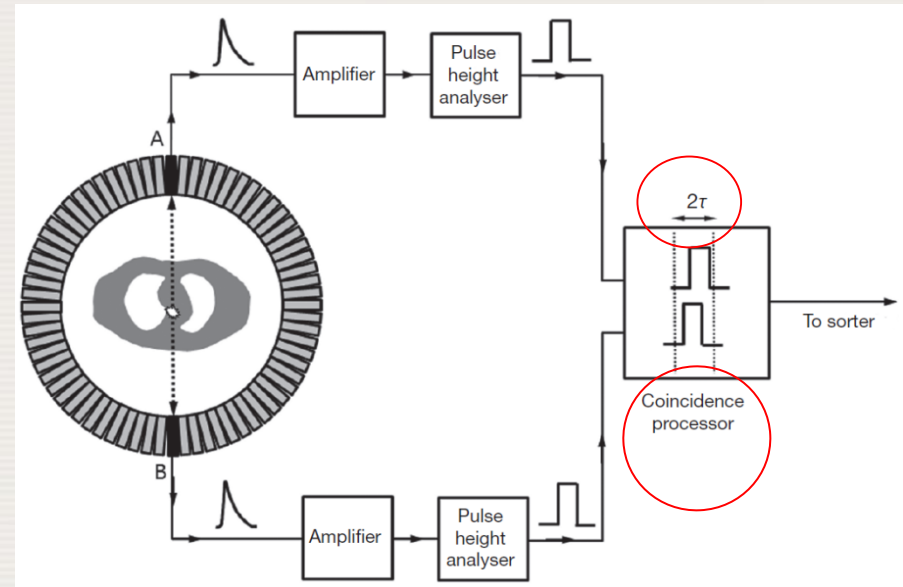

11.3 POSITRON EMISSION TOMOGRAPHY SYSTEMS

11.3.4 Data acquisition

11.3.4.2 Data acquisition geometries

- ❑ The data acquisition geometry refers to the arrangement of detector pairs that are permitted to form coincidence events and, in practice, involves the presence or absence of interplane septa.
- ❑ Data acquisition with septa in place is referred to as 2-D mode; data acquisition without any interplane septa is referred to as 3-D mode.
- ❑ In 3-D mode, the sensitivity variation in the axial direction is much greater than in 2D and has a triangular profile with a peak at the central slice.

11.3 POSITRON EMISSION TOMOGRAPHY SYSTEMS

11.3.4 Data acquisition

11.3.4.2 Data acquisition geometries

2-D acquisition geometry:

In 2-D mode(a), a series of annular septa are inserted in front of the detectors so as to absorb photons incident at oblique angles.

2-D acquisition is associated with a low rate of scattered coincidence events.

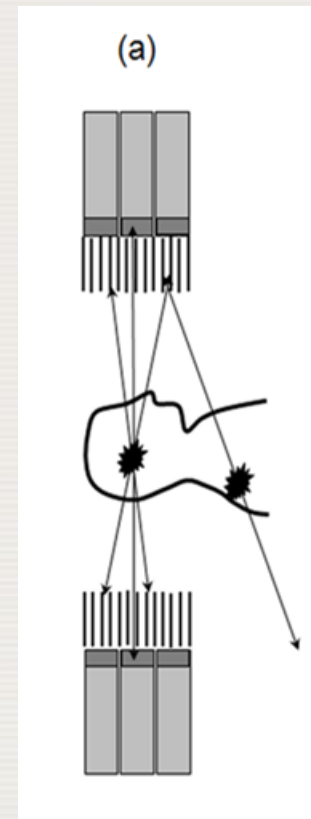

11.3 POSITRON EMISSION TOMOGRAPHY SYSTEMS

11.3.4 Data acquisition

11.3.4.2 Data acquisition geometries

3-D acquisition geometry:

In 3-D mode(b), these septa are removed, allowing oblique photons to reach the detectors.

3-D mode is associated with high sensitivity but also increased scatter and randoms fractions.

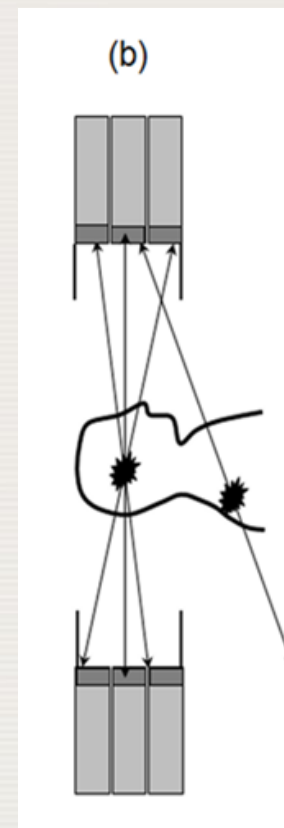

11.3 POSITRON EMISSION TOMOGRAPHY SYSTEMS

11.3.4 Data acquisition

11.3.4.2 Data acquisition geometries

- ❑ The advantage of 3-D acquisition is its large increase in sensitivity compared to 2-D acquisition.
- ❑ The relative contribution of randoms and scattered photons is patient specific and both increase with increasing patient size.

11.3 POSITRON EMISSION TOMOGRAPHY SYSTEMS

11.3.4 Data acquisition

11.3.4.2 Data acquisition geometries

Noise equivalent count rate (NECR)

The noise equivalent count rate (NECR) is equivalent to the coincidence count rate that would have the same noise properties as the measured true rate after correcting for randoms and scatter.

11.3 POSITRON EMISSION TOMOGRAPHY SYSTEMS

11.3.4 Data acquisition

11.3.4.2 Data acquisition geometries

The NECR is computed using:

$$\text{NECR} = \frac{T^2}{T + S + 2fR}$$

where T , S and R are the true, scatter and random coincidence count rates, respectively, and f is the fraction of the sinogram width that intersects the phantom.

11.3 POSITRON EMISSION TOMOGRAPHY SYSTEMS

11.3.4 Data acquisition

11.3.4.2 Data acquisition geometries

Trues count rate

- At low activities, the true coincidence count rate increases linearly with activity.
- However, at higher activities, detector dead time becomes increasingly significant.
- The trues rate increases less rapidly with increasing activity and can even decrease at very high activities.

11.3 POSITRON EMISSION TOMOGRAPHY SYSTEMS

11.3.4 Data acquisition

11.3.4.2 Data acquisition geometries

Randoms and scatter count rates

- ❑ The randoms count rate increases with increasing activity as a greater number of photons are detected.
- ❑ The scatter count rate is assumed to be proportional to the true rate.
- ❑ Scanner count rate performance can be characterized using the noise equivalent count rate (NECR), which is a function of the true, random and scatter coincidence count rates.

11.3 POSITRON EMISSION TOMOGRAPHY SYSTEMS

11.3.4 Data acquisition

11.3.4.2 Data acquisition geometries

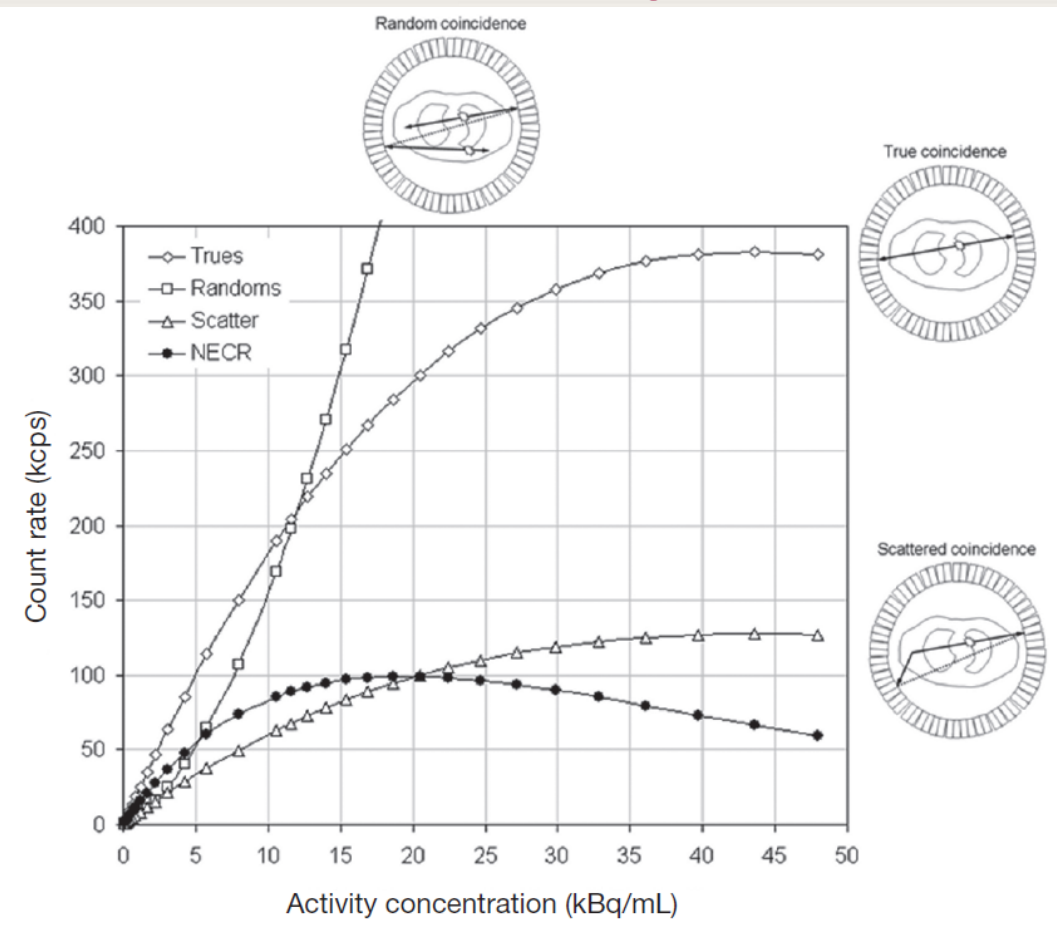

Trues, scattered, randoms and NECR vs activity concentration



11.3 POSITRON EMISSION TOMOGRAPHY SYSTEMS

11.3.4 Data acquisition

11.3.4.2 Data acquisition geometries

BGO and 2-D mode

- ❑ In 2-D mode, the septa substantially reduce dead time, randoms and scatter, making the poor timing and energy resolution of BGO less of a limitation.
- ❑ Therefore, BGO can perform adequately in 2-D detection mode.

11.3 POSITRON EMISSION TOMOGRAPHY SYSTEMS

11.3.4 Data acquisition

11.3.4.2 Data acquisition geometries

LSO and 3-D mode

- ❑ The improved timing resolution of LSO can be used to reduce the coincidence time window and, thus, reduce the randoms fraction, which is high in 3-D mode.
- ❑ The improved energy resolution also allows the lower level energy discriminator to be raised, resulting in a lower scatter fraction, being well suited for 3-D acquisition mode.

11.3 POSITRON EMISSION TOMOGRAPHY SYSTEMS

11.3.4 Data acquisition

11.3.4.3 Data organization

Data recording

- The data recorded during a conventional PET acquisition are typically binned into 2-D matrices known as sinograms.
- If a 2-D acquisition geometry is considered, each row of the sinogram represents a projection of the radionuclide distribution at a particular angle around the patient.
- The sinogram is indexed along the y axis by angle and the x axis by distance.

11.3 POSITRON EMISSION TOMOGRAPHY SYSTEMS

11.3.4 Data acquisition

11.3.4.3 Data organization

Measuring multiple projections

Full ring PET scanners

simultaneously measure multiple projections at different angles ϕ with respect to the patient.

An example showing the orientation of two parallel projections is shown in (a).

Projection data of this sort are typically stored in sinograms; an example is shown in (b)

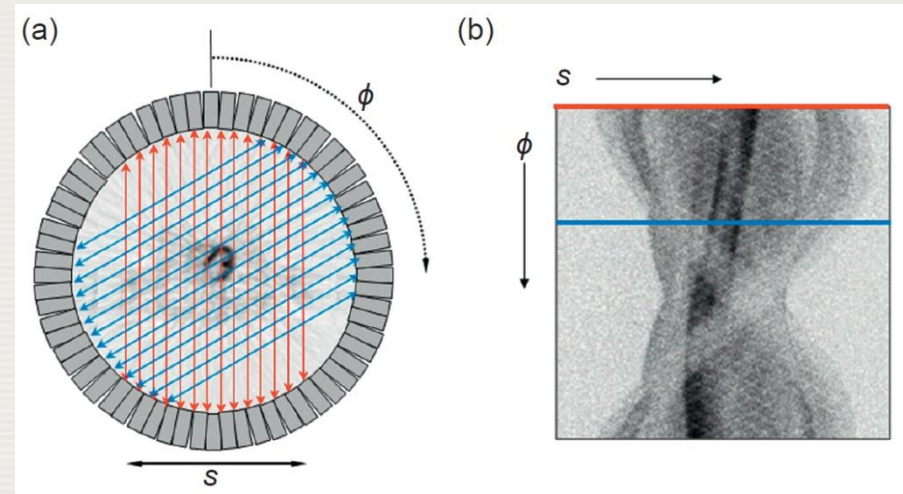

11.3 POSITRON EMISSION TOMOGRAPHY SYSTEMS

11.3.4 Data acquisition

11.3.4.3 Data organization

Direct plane and oblique planes data

- ❑ 2-D acquisition mode only considered coincidence events between detectors in a single ring, referred to as a direct plane.
- ❑ Coincidence events between detectors in immediately adjacent rings are combined into a sinogram that is considered to have been measured in a plane located between the two detector rings.

11.3 POSITRON EMISSION TOMOGRAPHY SYSTEMS

11.3.4 Data acquisition

11.3.4.3 Data organization

Direct plane and oblique planes data

- The purpose of acquiring the additional oblique data is to increase sensitivity and reduce statistical noise in the resulting images.

11.3 POSITRON EMISSION TOMOGRAPHY SYSTEMS

11.3.4 Data acquisition

11.3.4.3 Data organization

PET scanner in 2-D (a and b) and 3-D (c) acquisition modes

- a) Lines of response joining opposing detectors in the same ring forming direct planes.
- b) Lines of response between detectors in adjacent rings.
- c) 3-D acquisition in which each ring is permitted to form coincidence events with all other rings.

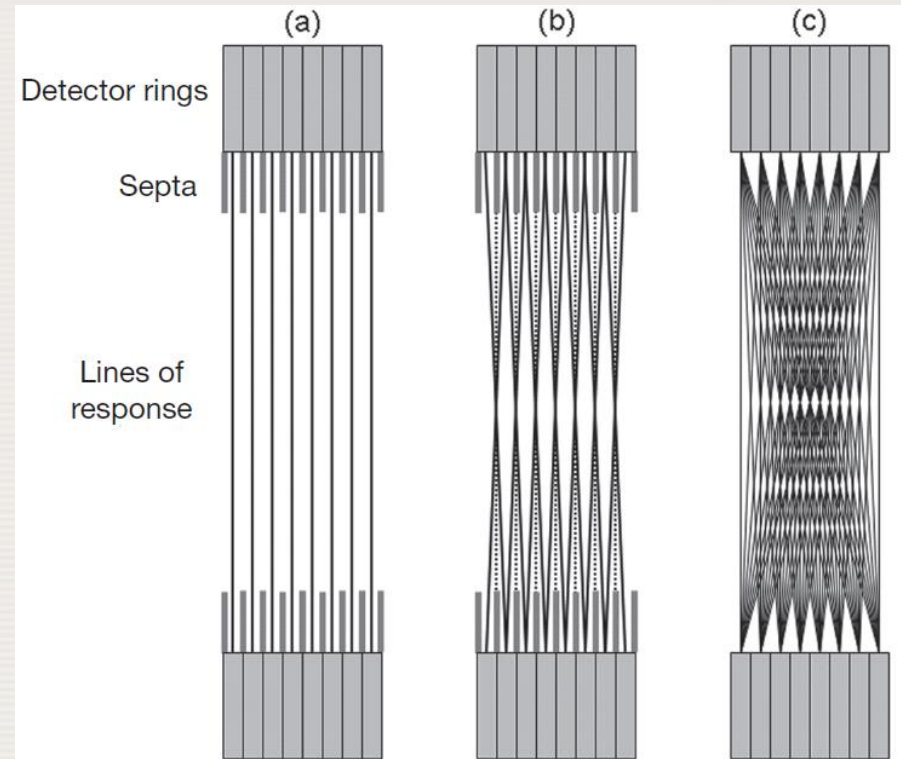

11.3 POSITRON EMISSION TOMOGRAPHY SYSTEMS

11.3.4 Data acquisition

11.3.4.3 Data organization

Restrictions for coincidences

- ❑ Sensitivity is further increased for cross planes by extending the ring difference between which coincidences are allowed from one to three or higher odd numbers.
- ❑ In 3-D acquisition mode, there is no longer any physical restriction on the detector rings that can be used to measure coincidence events.

11.3 POSITRON EMISSION TOMOGRAPHY SYSTEMS

11.3.4 Data acquisition

11.3.4.3 Data organization

Number of possible sinograms

For a N ring scanner, the number of possible sinograms is:

- ❑ In 2-D mode: $2N-1$
- ❑ In 3-D mode: N^2

11.3 POSITRON EMISSION TOMOGRAPHY SYSTEMS

11.3.4 Data acquisition

11.3.4.4 Time of flight (TOF)

- ❑ It has long been appreciated that the difference in the detection times of the two annihilation photons provides a mechanism for precisely localizing the site of individual positron–electron annihilations.
- ❑ Incorporating information derived from differences in the photon arrival times has been referred to as TOF mode.
- ❑ A prerequisite for TOF PET systems is high timing resolution.

11.3 POSITRON EMISSION TOMOGRAPHY SYSTEMS

11.3.4 Data acquisition

11.3.4.4 Time of flight (TOF)

A coincidence event is detected along a line of response between detectors A and B.

The average time difference between the two detectors is given by:

$$(x + \Delta x)/c - (x - \Delta x)/c = 2\Delta x/c$$

where c is the speed of light.

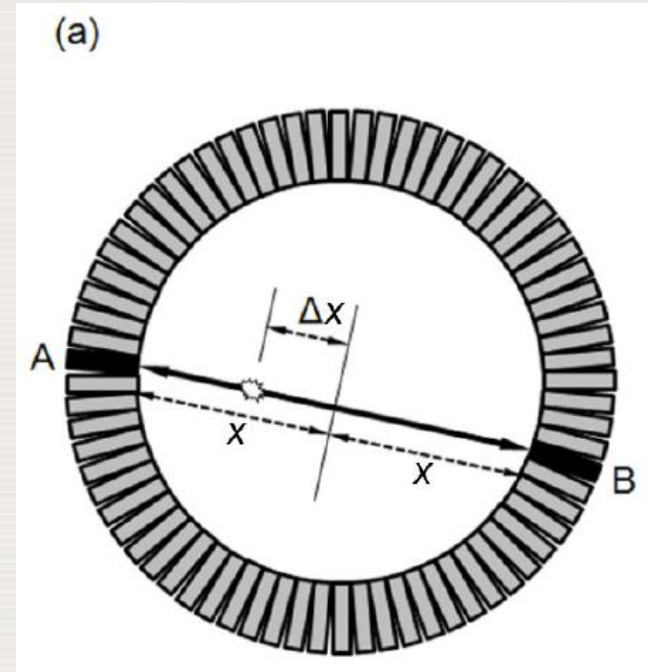

11.3 POSITRON EMISSION TOMOGRAPHY SYSTEMS

11.3.4 Data acquisition

11.3.4.4 Time of flight (TOF)

Conventional PET

With conventional PET, no information is available about the location of the annihilation event along the line of response.

During reconstruction, the event is assigned with equal weight to all pixels between A and B.

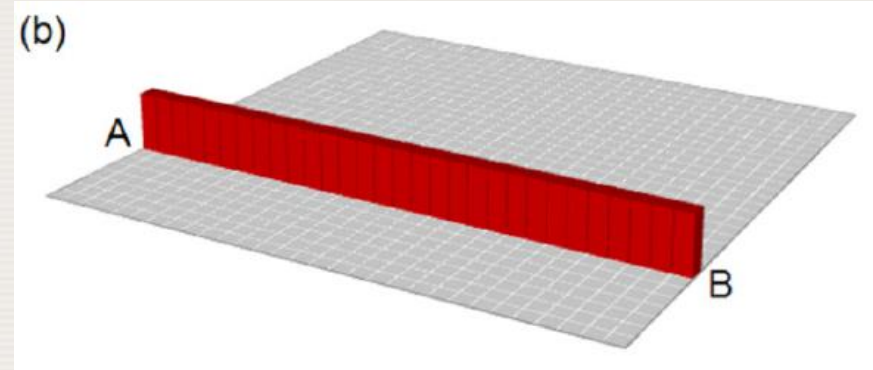

11.3 POSITRON EMISSION TOMOGRAPHY SYSTEMS

11.3.4 Data acquisition

11.3.4.4 Time of flight (TOF)

TOF PET

With time of flight PET, the time difference between the signals recorded at detectors A and B is used to estimate the position of the annihilation event along the line of response.

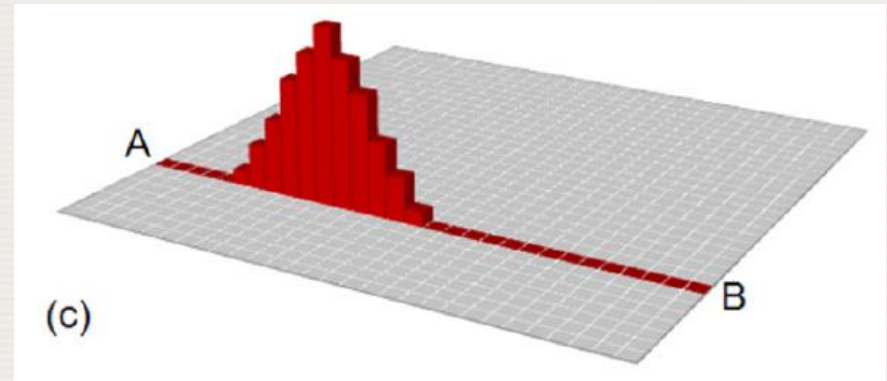

11.3 POSITRON EMISSION TOMOGRAPHY SYSTEMS

11.3.4 Data acquisition

11.3.4.4 Time of flight (TOF)

Requirements for TOF imaging

- ❑ The additional TOF information has data management considerations because an extra dimension has been added to the data set.
- ❑ TOF sinograms require dedicated reconstruction algorithms that incorporate the TOF information into the image reconstruction.

11.3 POSITRON EMISSION TOMOGRAPHY SYSTEMS

11.3.4 Data acquisition

11.3.4.4 Time of flight (TOF)

Benefits of TOF

- ❑ TOF has potential benefits for body imaging, particularly in large patients where high attenuation and scatter mean that image quality is usually poorest.

11.3 POSITRON EMISSION TOMOGRAPHY SYSTEMS

11.3.5 Data corrections

11.3 POSITRON EMISSION TOMOGRAPHY SYSTEMS

11.3.5 Data corrections

11.3.5.1 Normalization

- ❑ Normalization refers to a software correction that is applied to the measured projection data in order to compensate for variations in the sensitivity of different LORs.
- ❑ It is somewhat analogous to the uniformity correction applied to gamma camera images.

11.3 POSITRON EMISSION TOMOGRAPHY SYSTEMS

11.3.5 Data corrections

11.3.5.1 Normalization

- ❑ Separate 2-D and 3-D normalizations are required for systems capable of acquiring data in both modes.
- ❑ Normalization files are experimentally determined correction factors that are applied as multiplicative terms for each LOR.
- ❑ They are periodically updated to reflect the current state of the detector system and are applied to all subsequently acquired data.

11.3 POSITRON EMISSION TOMOGRAPHY SYSTEMS

11.3.5 Data corrections

Sinograms corresponding to a centrally located uniform cylinder, (a) before normalization and (b) after normalization.

Transverse images are shown for reconstructions without normalization (c) and with normalization (d).

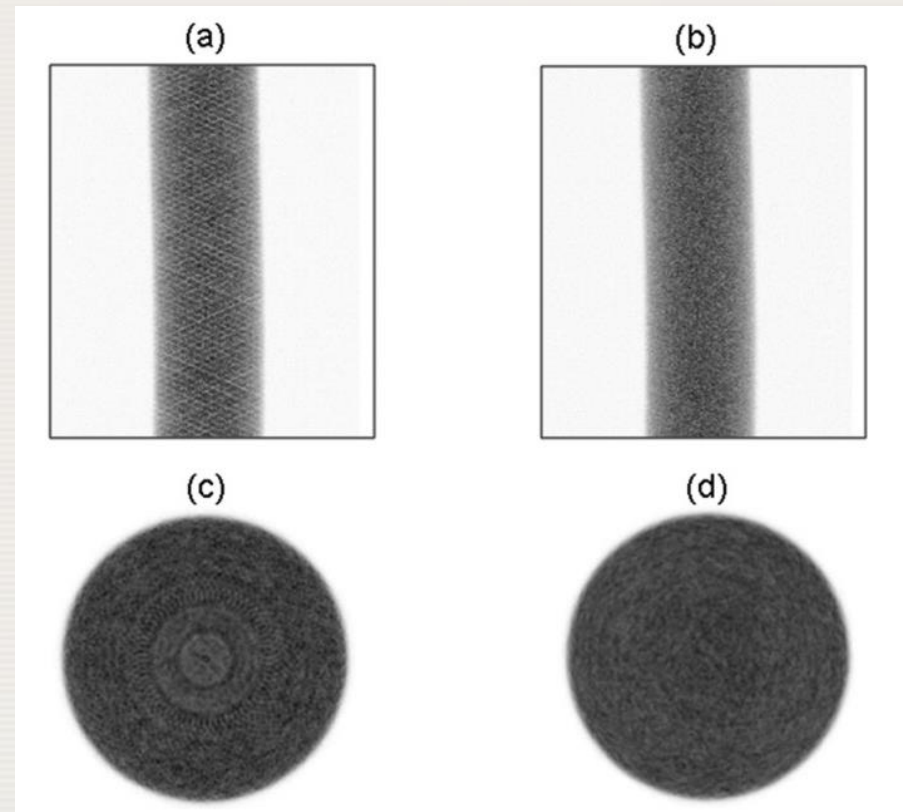

11.3 POSITRON EMISSION TOMOGRAPHY SYSTEMS

11.3.5 Data corrections

11.3.5.2 Randoms correction

- ❑ Randoms make up a potentially large component of all measured coincidence events.
- ❑ Randoms correction is essential for all quantitative studies and is routinely implemented on almost all scanner systems.

11.3 POSITRON EMISSION TOMOGRAPHY SYSTEMS

11.3.5 Data corrections

11.3.5.2 Randoms correction

- ❑ One widely adopted correction method involves estimating the number of randoms contributing to the prompts (trues + scatter + randoms) using an additional coincidence circuit.
- ❑ The number of counts in the delayed channel provides an estimate of the randoms in the prompt channel.
- ❑ The delayed data are automatically subtracted from the corresponding prompt data, providing an on-line randoms correction.

11.3 POSITRON EMISSION TOMOGRAPHY SYSTEMS

11.3.5 Data corrections

11.3.5.2 Randoms correction

(a) Detection events from two opposing detectors, indicating three coincidence events in the prompt circuit.

(b) Data from detector 2 delayed with respect to detector 1 and indicating one coincidence event in this delayed circuit.

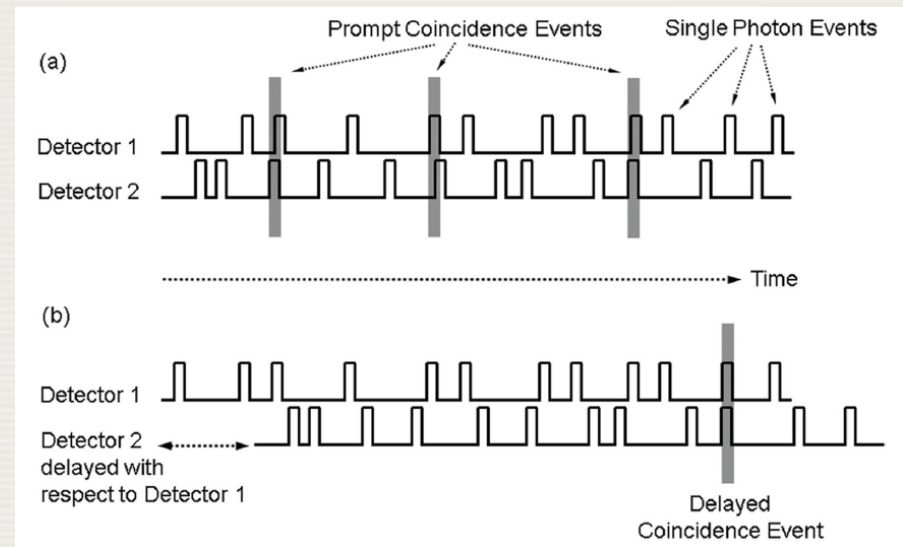

11.3 POSITRON EMISSION TOMOGRAPHY SYSTEMS

11.3.5 Data corrections

11.3.5.2 Randoms correction.

Differences for trues and randoms in the delayed circuit

- The temporal delay prevents true coincidence events from being recorded in the delayed circuit.
- Random coincidence events still occur with the same frequency as in the prompt circuit.

11.3 POSITRON EMISSION TOMOGRAPHY SYSTEMS

11.3.5 Data corrections

11.3.5.2 Randoms correction

- ❑ The delayed channel does not identify and remove individual random coincidences from the prompt measurement.
- ❑ Instead, it estimates the average number of randoms that might be expected.
- ❑ An alternative method of randoms correction is to estimate the randoms for each LOR using the singles rates at the corresponding detectors.

11.3 POSITRON EMISSION TOMOGRAPHY SYSTEMS

11.3.5 Data corrections

11.3.5.3 Attenuation correction

- ❑ One of the advantages of PET over SPECT is the ease with which attenuation correction can be performed.
- ❑ It can be seen that the probability of a coincidence event occurring decreases as the thickness of attenuating material increases.
- ❑ However, this probability is not dependent on the location of the source along a particular LOR, differing from SPECT.

11.3 POSITRON EMISSION TOMOGRAPHY SYSTEMS

11.3.5 Data corrections

11.3.5.3 Attenuation correction

When considering both back to back photons along a particular line of response, the attenuation experienced by a point source within the body (a) is independent of its location along the line and is given by $e^{-\mu D}$ for a uniformly attenuating object.

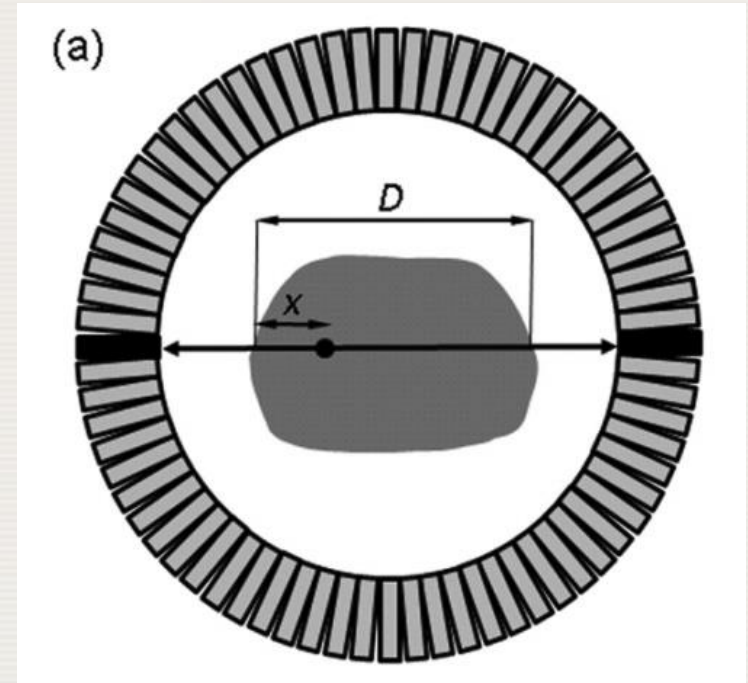

11.3 POSITRON EMISSION TOMOGRAPHY SYSTEMS

11.3.5 Data corrections

11.3.5.3 Attenuation correction

In (b), the positron emitting transmission source is outside the patient but experiences the same attenuation as the internal source when considering coincidence events along the same line of response.

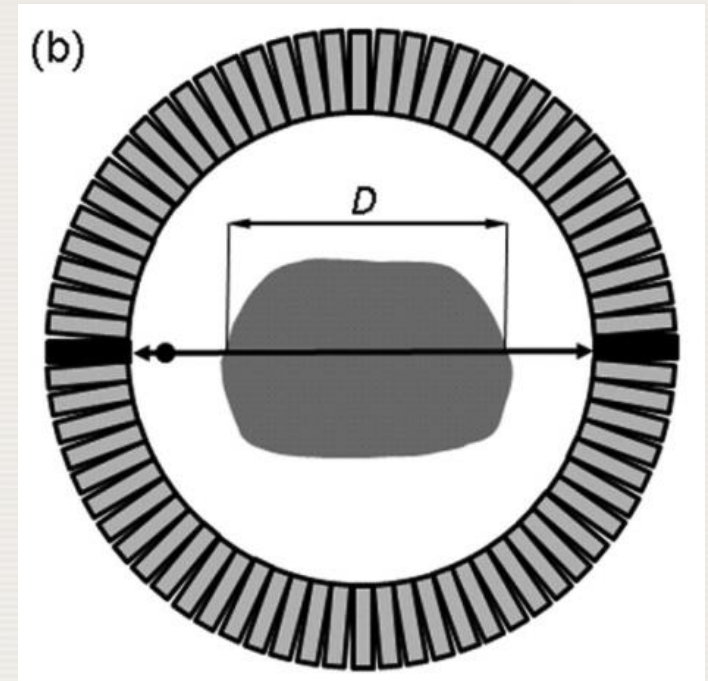

11.3 POSITRON EMISSION TOMOGRAPHY SYSTEMS

11.3.5 Data corrections

11.3.5.3 Attenuation correction

The attenuation factor AF for a particular LOR is given by:

$$AF = e^{-\int \mu(x) dx}$$

where $\mu(x)$ refers to the spatially-variant distribution of linear attenuation coefficients within the body and the integral is over the LOR joining opposing detectors.

11.3 POSITRON EMISSION TOMOGRAPHY SYSTEMS

11.3.5 Data corrections

11.3.5.3 Attenuation correction

- The attenuation factor is dependent only on the material along the LOR.
- It is identical to the attenuation experienced by an external source of 511 keV photons along the same line.

11.3 POSITRON EMISSION TOMOGRAPHY SYSTEMS

11.3.5 Data corrections

11.3.5.3 Attenuation correction

Transmission systems developed

- ^{68}Ge rotating rod sources
- ^{137}Cs rotating point sources
- CT based transmission system

Currently, CT methods are employed, with additional corrections due to the differences between PET and CT acquisitions (time, FOV, energy).

11.3 POSITRON EMISSION TOMOGRAPHY SYSTEMS

11.3.5 Data corrections

11.3.5.3 Attenuation correction

- ❑ For PET attenuation correction, CT images have to be rescaled from Hounsfield units (HU) to linear attenuation coefficients (μ) appropriate for 511 keV.
- ❑ Multi-linear scaling functions have been used.
- ❑ The rescaled CT images are then forward projected to produce attenuation correction factors that are applied to the PET emission data, prior to or during image reconstruction.

11.3 POSITRON EMISSION TOMOGRAPHY SYSTEMS

11.3.5 Data corrections

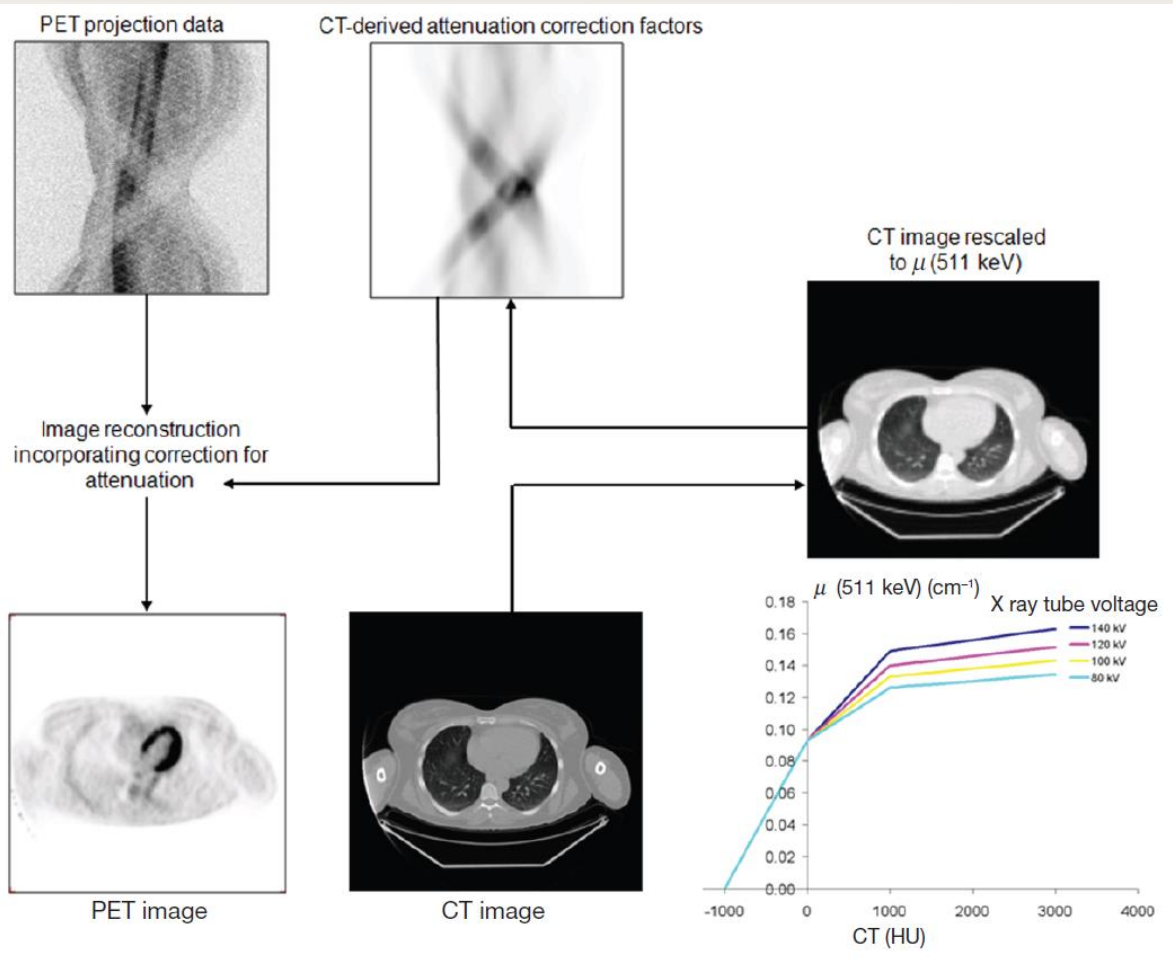

11.3 POSITRON EMISSION TOMOGRAPHY SYSTEMS

11.3.5 Data corrections

11.3.5.4 Scatter correction

- ❑ Scatter correction is required because the limited energy resolution of PET systems .
- ❑ Scatter contribution is higher in 3-D than 2-D acquisitions, where physical collimation limits scattered photons.
- ❑ Scatter background is a complex function of both the emission and attenuation distributions and is non-uniform across the FOV. Several algorithms have been developed, using either experimental data or model based approach.

11.3 POSITRON EMISSION TOMOGRAPHY SYSTEMS

11.3.5 Data corrections

11.3.5.5 Dead time correction

- ❑ If a second photon is incident upon a detector while an earlier photon is still being processed, the secondary photon may be lost.
- ❑ The likelihood of this occurring increases at high count rates and results in an effective loss of sensitivity.
- ❑ Dead time correction compensates for this loss of sensitivity. Corrections are usually based upon experimental measurements of the scanner's response to a decaying source of activity.

11.3 POSITRON EMISSION TOMOGRAPHY SYSTEMS

11.3.5 Data corrections

11.3.5.6 Image calibration

- ❑ After image reconstruction, including the application of the various physical corrections, PET images have arbitrary units, typically counts per voxel per second.
- ❑ In order to convert the PET images into units of absolute activity concentration such as becquerels per millilitre, a calibration factor is required.
- ❑ This calibration factor is experimentally determined, usually using a uniform cylinder phantom.

11.3 POSITRON EMISSION TOMOGRAPHY SYSTEMS

11.3.5 Data corrections

11.3.5.6 Image calibration

The calibration factor CF can be determined using:

$$CF = \frac{A}{V} \times \frac{p}{C}$$

where A/V is the known activity concentration (Bq/mL) within the phantom; C is the mean voxel data (counts \cdot voxel $^{-1} \cdot$ s $^{-1}$) from a large region well within the cylinder part of the image; and p is the positron fraction of the radionuclide used in the calibration experiment (typically ^{18}F , positron fraction 0.97).

11.4 SPECT/CT AND PET/CT SYSTEMS

11.4.1 CT uses in emission tomography

11.4 SPECT/CT AND PET/CT SYSTEMS

11.4.1 CT uses in emission tomography

- ❑ SPECT and PET typically provide very little anatomical information.
- ❑ Relating radionuclide uptake to high resolution anatomic imaging (CT or MRI) greatly aids localization and characterization of disease but ideally requires the two images to be spatially registered.
- ❑ Combined scanner systems, such as SPECT/CT and PET/CT, provide a solution. The advantage of this hardware approach is that images from the two modalities are inherently registered with no need for further manipulation.

11.4 SPECT/CT AND PET/CT SYSTEMS

11.4.1 CT uses in emission tomography

- ❑ The coupling of CT with SPECT and PET systems provides an additional technical benefit.
- ❑ The availability of co-registered CT is particularly advantageous for attenuation correction.
- ❑ In the case of SPECT, the main advantages of CT based attenuation correction are greater accuracy and reliability compared to radionuclide sources.
- ❑ In PET, the main advantage is an effective reduction in the overall duration of the scanning procedure owing to the speed with which CT images can be acquired.

11.4 SPECT/CT AND PET/CT SYSTEMS

11.4.2 SPECT/CT

11.4 SPECT/CT AND PET/CT SYSTEMS

11.4.2 SPECT/CT

- ❑ SPECT might be expected to benefit more than PET from the addition of registered CT.
- ❑ SPECT has lower spatial resolution than PET.
- ❑ Many SPECT tracers are quite specific and often do not offer useful anatomical orientation.
- ❑ Radionuclide transmission scanning is more awkward in SPECT compared to PET.

The adoption of combined SPECT/CT instrumentation has been slower than that of PET/CT, possibly due to cost considerations.

11.4 SPECT/CT AND PET/CT SYSTEMS

11.4.2 SPECT/CT

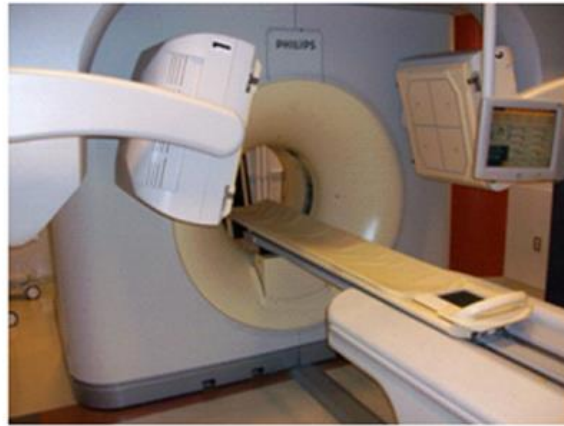

Clinical SPECT/CT systems

11.4 SPECT/CT AND PET/CT SYSTEMS

11.4.2 SPECT/CT

- ❑ A number of different multi-detector CT slice configurations are available, as well as alternative designs including those based upon flat panel detectors and improvements of the original low cost, non-diagnostic CT.
- ❑ This broad range of CT capabilities may reflect a diversity of opinion about the role of combined SPECT/CT in clinical practice.

11.4 SPECT/CT AND PET/CT SYSTEMS

11.4.3 PET/CT

11.4 SPECT/CT AND PET/CT SYSTEMS

11.4.3 PET/CT

Advances in PET

- New detector materials
- New reconstruction methods
- Increased spatial resolution
- Improved image statistical quality

Advances in CT

- Spiral scanning
- Multidetector technology
- Extended FOV

11.4 SPECT/CT AND PET/CT SYSTEMS

11.4.3 PET/CT

- ❑ The addition of spatially registered anatomical information from the CT component of the combined scanner provided the impetus for widespread acceptance of PET in oncology and has driven the rapid growth of PET/CT instrumentation.
- ❑ PET/CT has now been rapidly accepted by the medical community, so much so that stand-alone PET systems are no longer being developed by the major commercial vendors.

11.4 SPECT/CT AND PET/CT SYSTEMS

11.4.3 PET/CT

Coronal images from a whole body fluorodeoxyglucose PET/CT study

- ❑ On the left, the PET data are shown in inverse grey scale.
- ❑ On the right, the same PET data are shown in a colour scale, superimposed on the CT in grey scale.

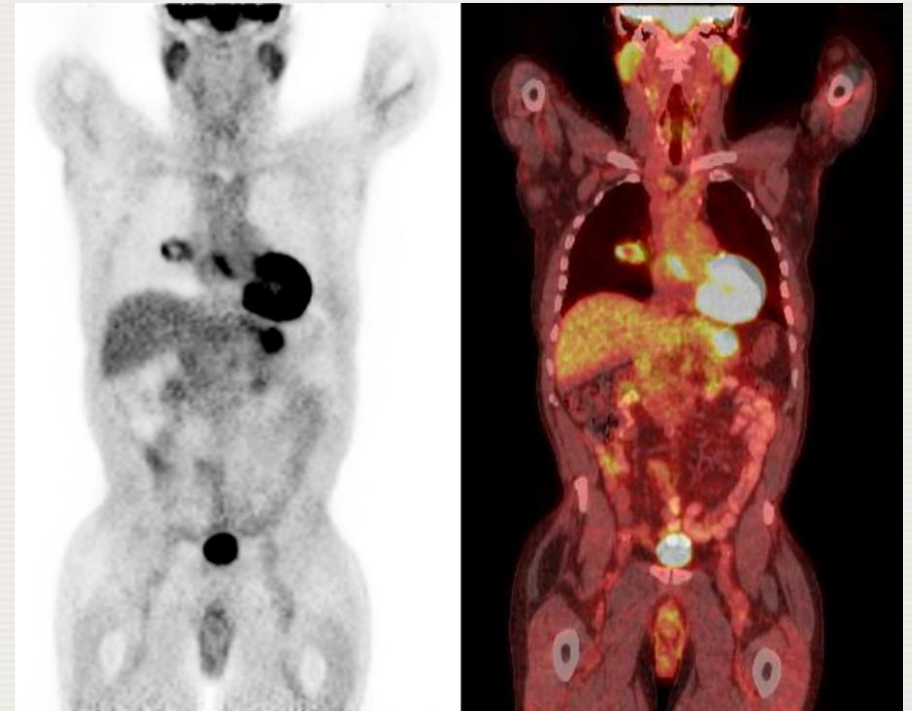

11.4 SPECT/CT AND PET/CT SYSTEMS

11.4.3 PET/CT

Current status of PET/CT technology

- ❑ Although the PET and CT detectors remain separate subsystems, many software functions of a modern PET/CT system run on a common platform.
- ❑ PET/CT systems have incorporated 4, 16 or 64 slice CT.
- ❑ The main advantage of CT based attenuation correction is the speed with which the data can be acquired.
- ❑ Whole body PET/CT scans can be done in a few minutes, mostly related to the PET component. Patient motion continues to be a problem.