

4. Acquisition of integral spectrum and differential spectrum setting two different modes of a ST-450 Counting System

Introduction

In this experiment, a ST-450 Counting System will be used for obtaining an integral-type and differential-type spectrum. The counting system consists of a single channel analyser (SCA), an amplifier and a power supply (adjusted from 200 to 1200 Volts). This will be connected to a standalone counter. The experiment will include a few steps as follows:

4.1. Determination of operation voltage of a NaI detector.

The aim of this experiment is aimed to determine the operating voltage of the NaI detector (1.5x1.5 inç) with the use of a photon source (^{137}Cs) if one does not know its specification value given by the manufacturer.

The output pulse of the detector is always proportional the energy deposited in the detector crystal. However, any changes in the voltage applied to the detector and gain settings of the amplifier, the amplitude of the pulse will also change and it will not be possible to obtain the true information about the source. Because of this, it is important to use all detectors at a specified operating voltage. For instance, the gain of the amplifier connected to the pre amplifier's output must be set at a constant value. At the same time the amplitude of pulses shall be observed from a scope. To perform this experiment, a block diagram showing the connections can be seen in Figure 1 in which a NaI detector and a ST-450 Counting System.

In order to avoid any saturation of the pulse amplitude, the amplifier gain is set a value to give a maximum 10 volt of the amplitude. Otherwise the pulses will be cut when a higher voltage is applied to the detector. In order to start this procedure, a standard calibration point source is used to count the gamma pulses (as shown in Fig.1).

In single channel analyser, a window is set with use of LLD and ULD settings. First a narrow window is selected. Then the high voltage is increased gently with small increments of about 50 V by using voltage knob until the γ rays coming from the standard source are placed in this window. Most of the pulses at the detector output are the same energy so the pulse count will have a maximum then it will decrease. The reason for this decrease is that the amplitude of the pulses will be out of the window and the counting system will not be able to count them when the voltage is too high.

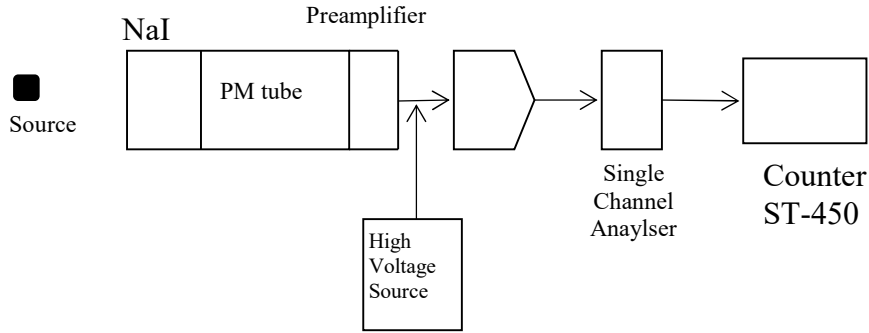

Şekil 1. The schema of NaI dedektör- ST-450 single channel analyser system

PROCEDURE

In this experiment a cylindrical NaI(Tl) detector with the crystal size of 38.1mmx38.1mm will be used. Its Model is 6S6P1.5VDC2 and series number S/N:09120402. This manufacture's information is specific to only this detector. If another type detector is chosen, the operating voltage will be different.

1. First connect the detector to the ST-450 counting system.
2. Connect the output of single channel analyser to the counter.
3. Place ^{137}Cs source at an appropriate shelf according to its activity.
4. At the same time connect the output of the amplifier to the scope with a T-connector.
5. Set the counting time to 30 seconds.
6. select a window range as %5 in front panel of ST-450.
7. Set the Coarse gain=8 and Fine gain=1 in front panel of ST-450.
8. Set the baseline to %66.2 in front panel of ST-450.
9. Be sure that ST-450 system and the standalone counter are connected and the cables provides from the energy source (adaptor and/or 220V mains).
10. Turn on the ST-450 system by using its push-button.
11. From the switch at the back of the ST-450 system, set high voltage from 650 V to 720 V in steps of 10 V and acquire count at every step. Then fill Table 1.
12. Determine the voltage that the maximum count is obtained and do a fine calibration in this step by changing the voltage in 1 V steps.

Note 1: After every count, reset the counts in the counter and change the voltage and start the the new count.

Some technical properties of ST-450:

Note 2: The applicable voltage range to the ST450 system is between 200-1200V. For this detector **the maximum operating voltage is 700 V**. Do not exceed this value in any conditions.

Note 3: The baseline is between 0%- 100% at ST450 system. It is set with the 10 turn at the knob.

Note 4: In the ST450 system, if you turn Coarse gain 6 times it amplifies the signal in an order of 2-64, if you turn Fine gain 10 times it amplifies the signal in an order of 0.5 to 1.5 .

Note 5: The window is between 1%-20% in ST450 system.

Table 1.

High Voltage (V)	Count
650	
660	
670	
680	
690	
700	
710	
720	

EVALUATION

1. Plot the high voltage- count graph and determine the energy range in every division in keV.
2. Prove that the operating voltage of this detector is 700 V from the obtained results. We predict this value is the best one. Why we should not the recommended voltage value. If someone exceeds this value, do you expect a catastrophic result on the detector