

TARIM MAKİNALARI TASARIMI



Prof.Dr. Ali İhsan Acar
Yrd.Doç.Dr.Caner Koç



6) Merkezleme yapılacak parçalara ön işlem yapılarak işlem basitleştirilmelidir.

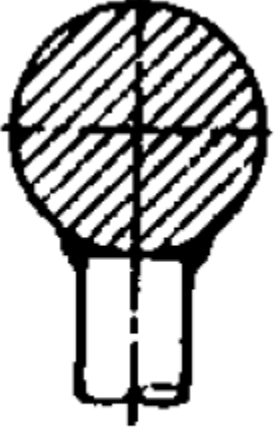

Küre başlık ile milin merkezlenmesi zordur

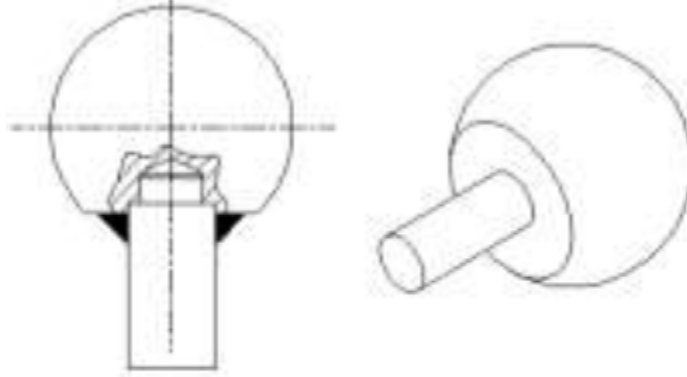

Küreye delik açılarak merkezlenme basitleştirilmiştir.

6) Merkezleme yapılacak parçalara ön işlem yapılarak işlem basitleştirilmelidir.

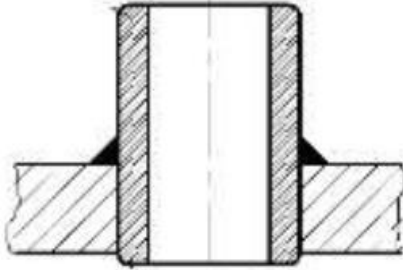
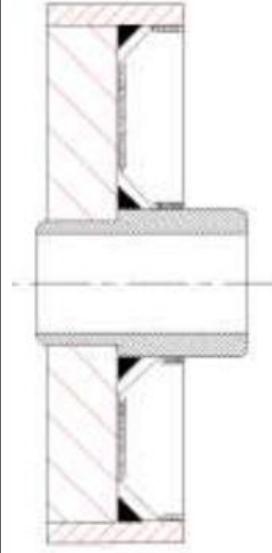
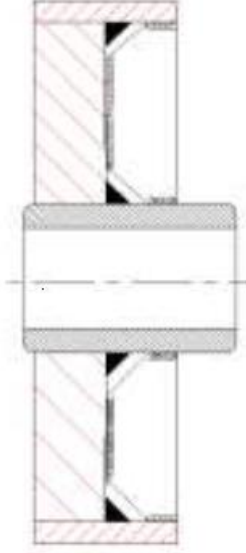

Burç levhaya delik açılarak merkezlenmiş. Burç ekseninin levhaya dik olarak kaynatılması zordur.

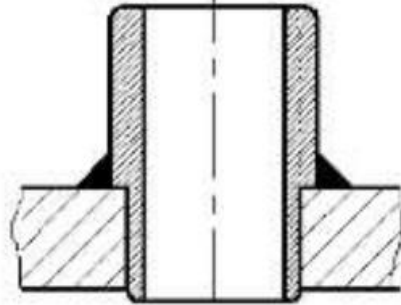

Burca fatura açılarak merkezleme basitleştirilmiştir.

7) Ön işlem yapmak yerine basit çözümler bulunmalı

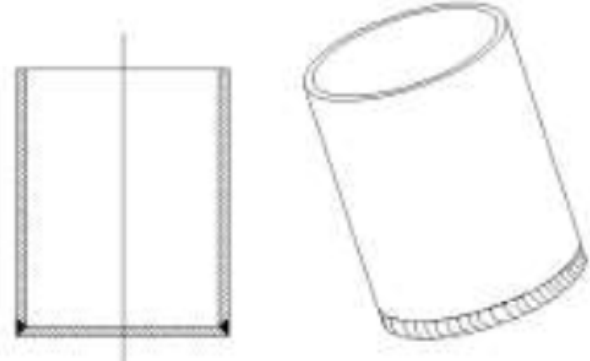

İki levhaya ayrı ayrı kaynak ağzı açılmış.

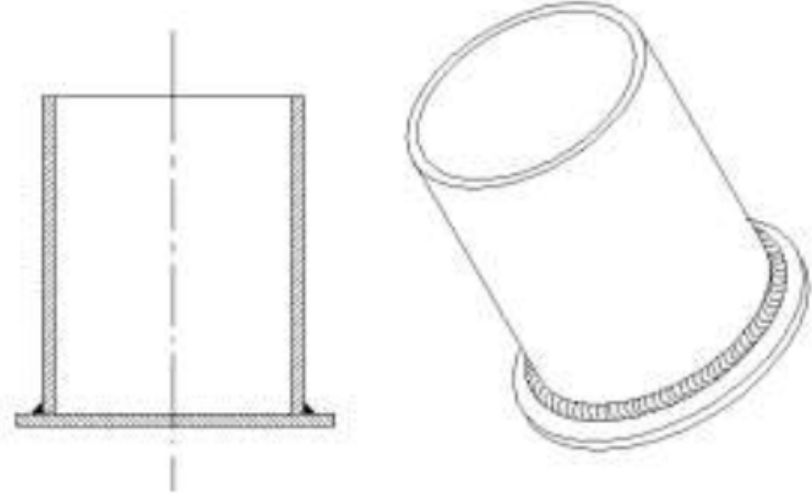

Levhalarından biri kaydırılarak ön işlemden yapmaya gerek kalmamış

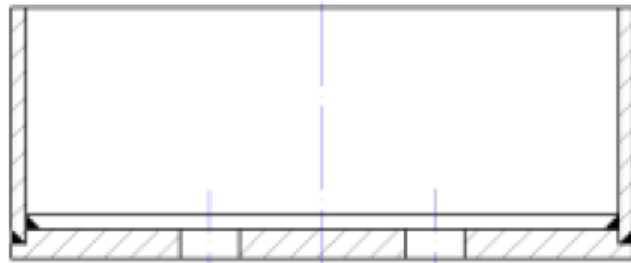

Silindir ve taban parçasına kaynak ağzı açılmış.

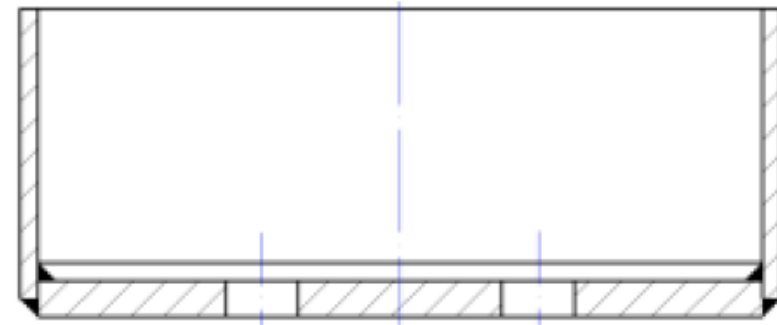

Alt parça kaydırılarak ön işlem yapmaya gerek kalmamış

7) Ön işlem yapmak yerine basit çözümler bulunmalı

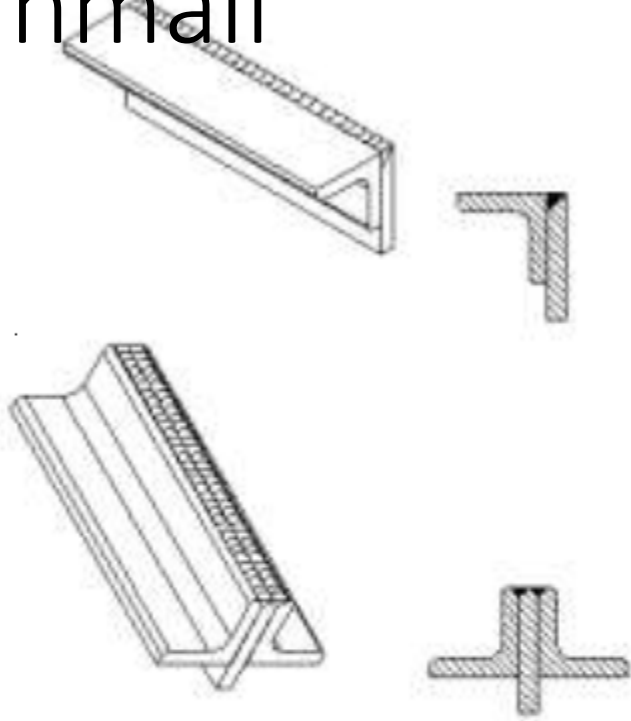

Köşebent ile levha birleştirmelerinde levhaya ön işlem yapılmış.

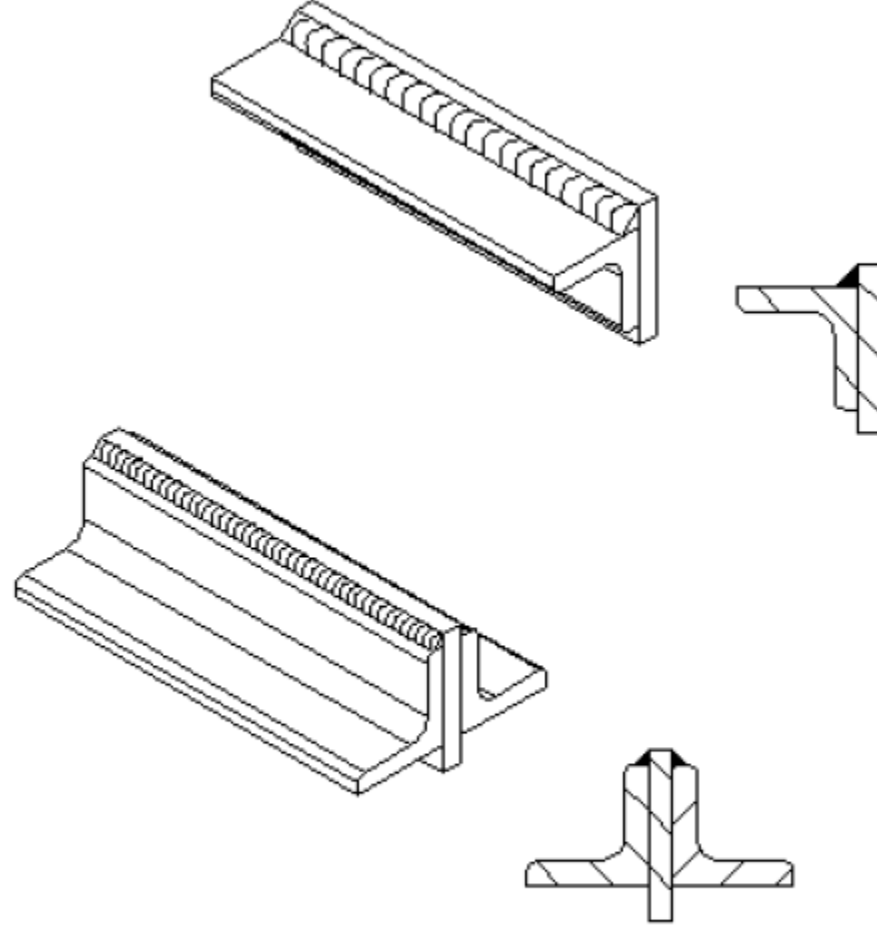

Levhalar kaydırılarak ön işlemde yapmaya gerek kalmamış

7) Ön işlem yapmak yerine basit çözümler bulunmalı



Levha ile köşebentler aynı hizada kaynatılmış.

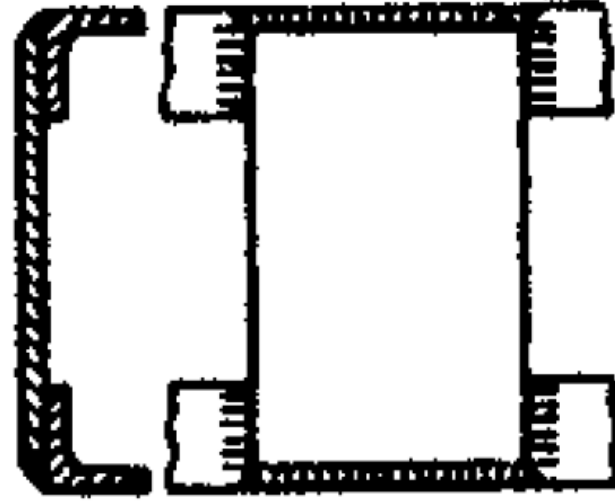

Köşebentler aşağı yukarı çekilerek kaynak ağzı oluşturulmuş.

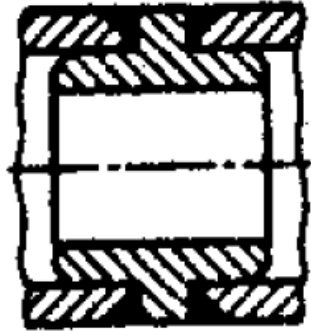

İki boru bir ara parça yardımıyla birleştirilmiş. Borulara kaynak ağzı açılmış.

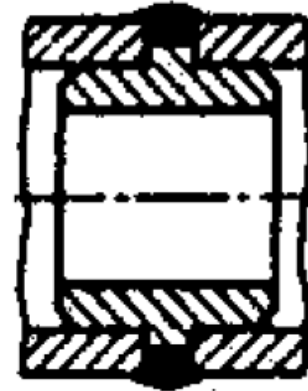

Ara parçanın dış çapı biraz küçük yapılarak kaynak ağzı oluşturulmuş.

7) Ön işlem yapmak yerine basit çözümler bulunmalı



Silindirik parça kapakla birleştirilmiş. Her iki parçaya da ön işlem yapılmış.

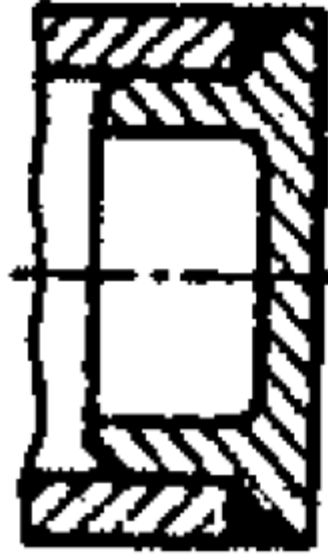

Sadece kapağa ön işlem yapılmış.

8) Parçaların üretimi basitleştirmeli

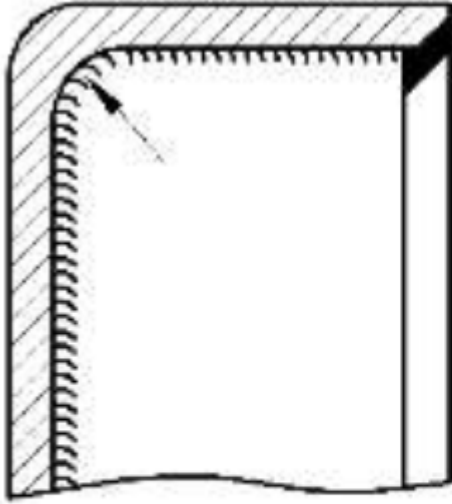

Silindirik parça ile düz levhanın birleştiği köşenin aynı yarıçapta işlenmesi zordur.

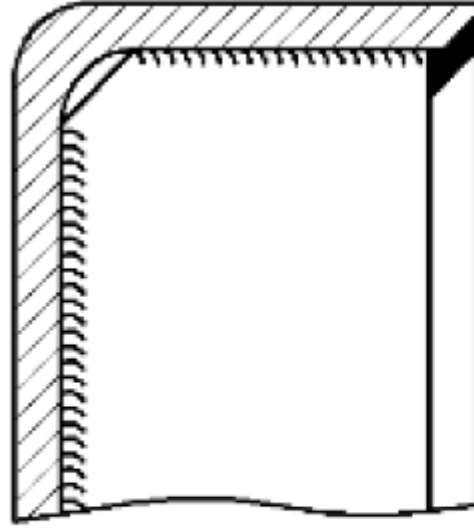

Levhanın köşesi kesilerek bu işleme gerek kalmamıştır.

8) Parçaların üretimi basitleştirmeli

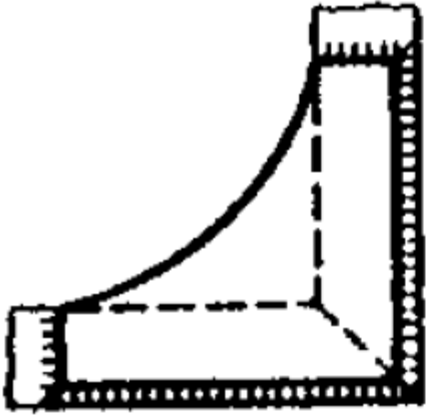

Destek levhası eğrisel işenmiş.

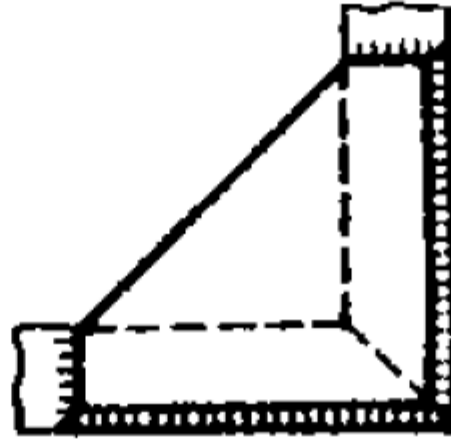

Destek levhasının düz kesilmesi daha kolaydır.

8) Parçaların üretimi basitleştirmeli

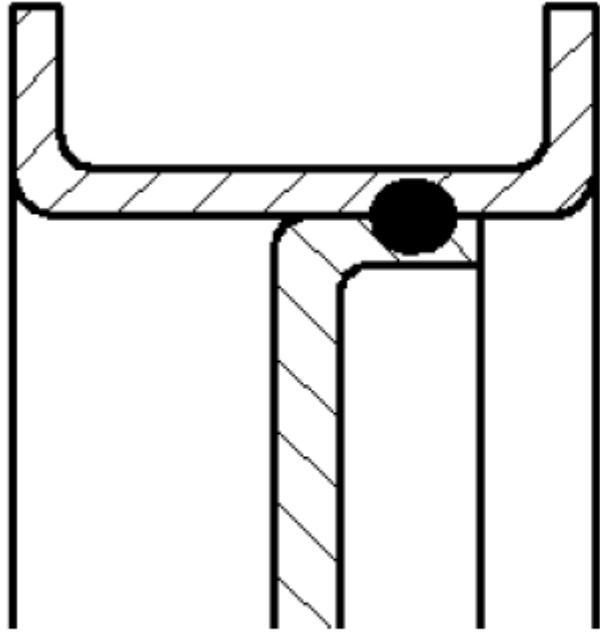

Şekildeki kasmağın yapılabilmesi için iki adet ayrı

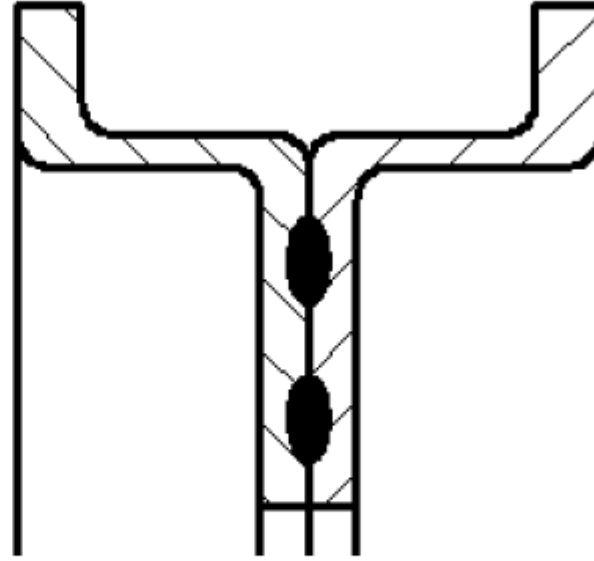

İki ayrı parça aynı şekil verilerek neticeye ulaşılmıştır.

8) Parçaların üretimi basitleştirmeli

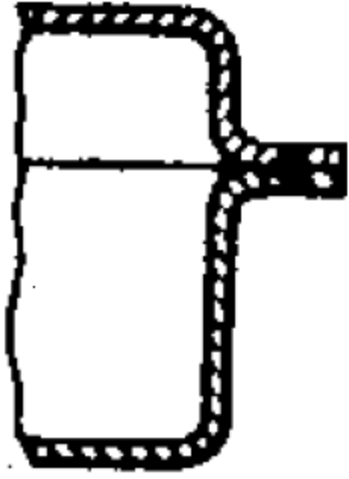

Silindirik parça için farklı şekilde iki parça gerekir.

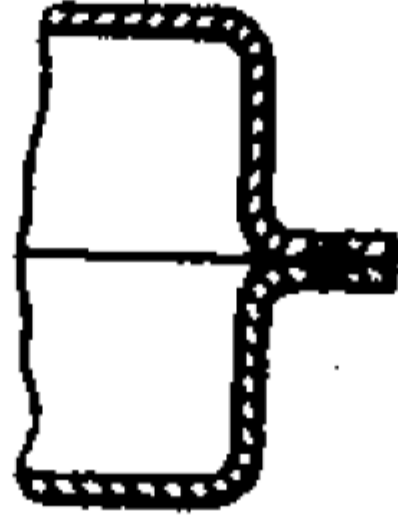

İki aynı parça ile neticeye varılmış.

8) Parçaların üretimi basitleştirmeli

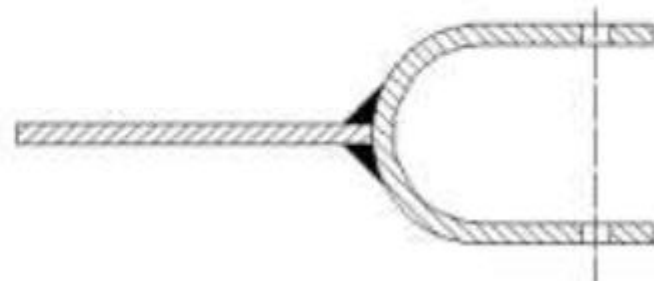
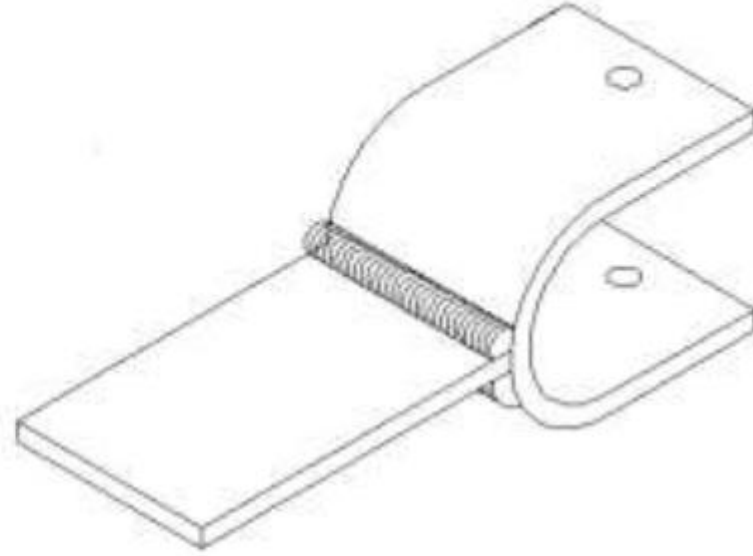
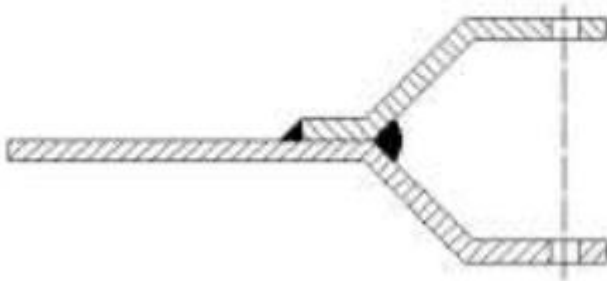
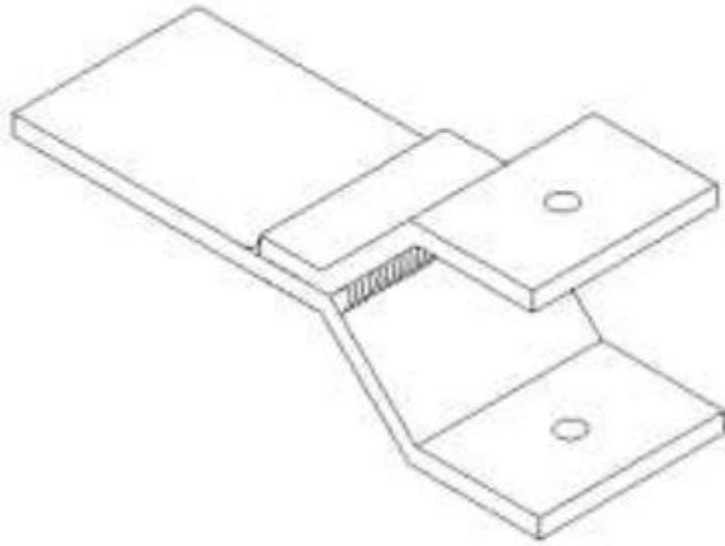

8) Parçaların üretimi basitleştirmeli

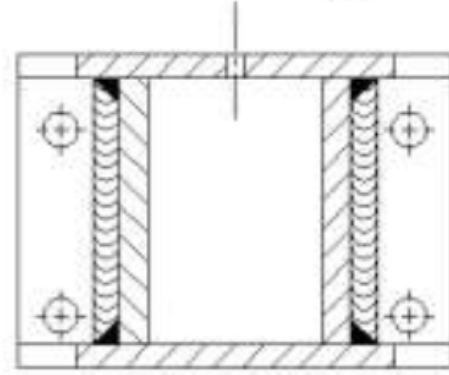
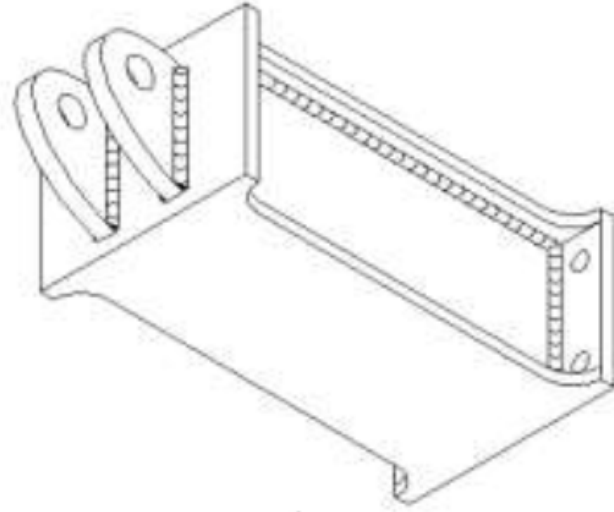

dört adet parça kaynaklanarak
kutu şeklinde parça
oluşturulmuş

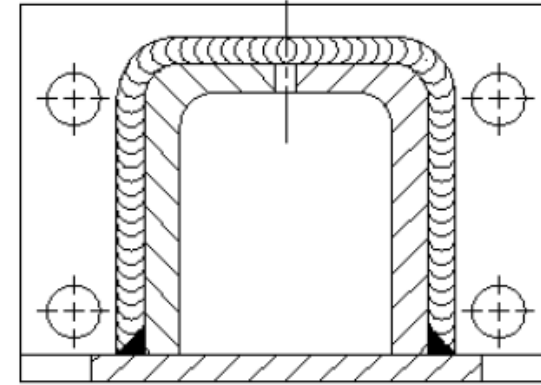
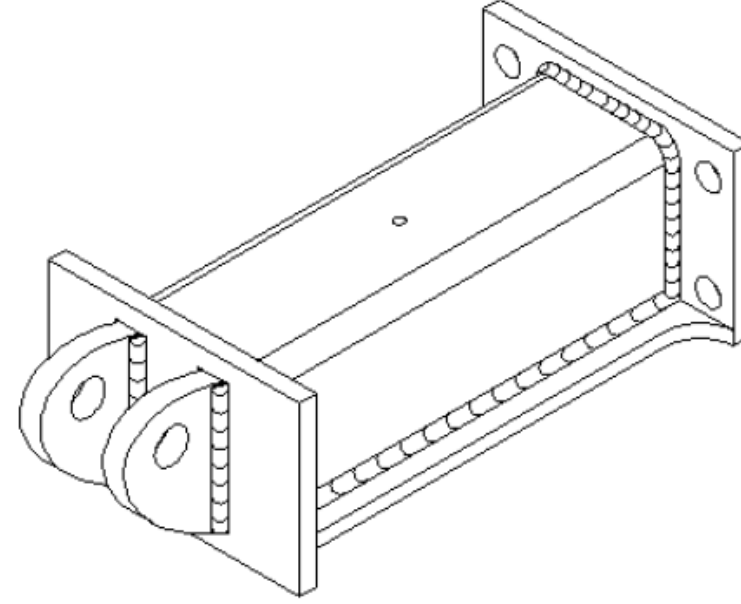

Üç adet parça yerine bir adet U şeklinde
parça kullanılmış

8) Parçaların üretimi basitleştirmeli

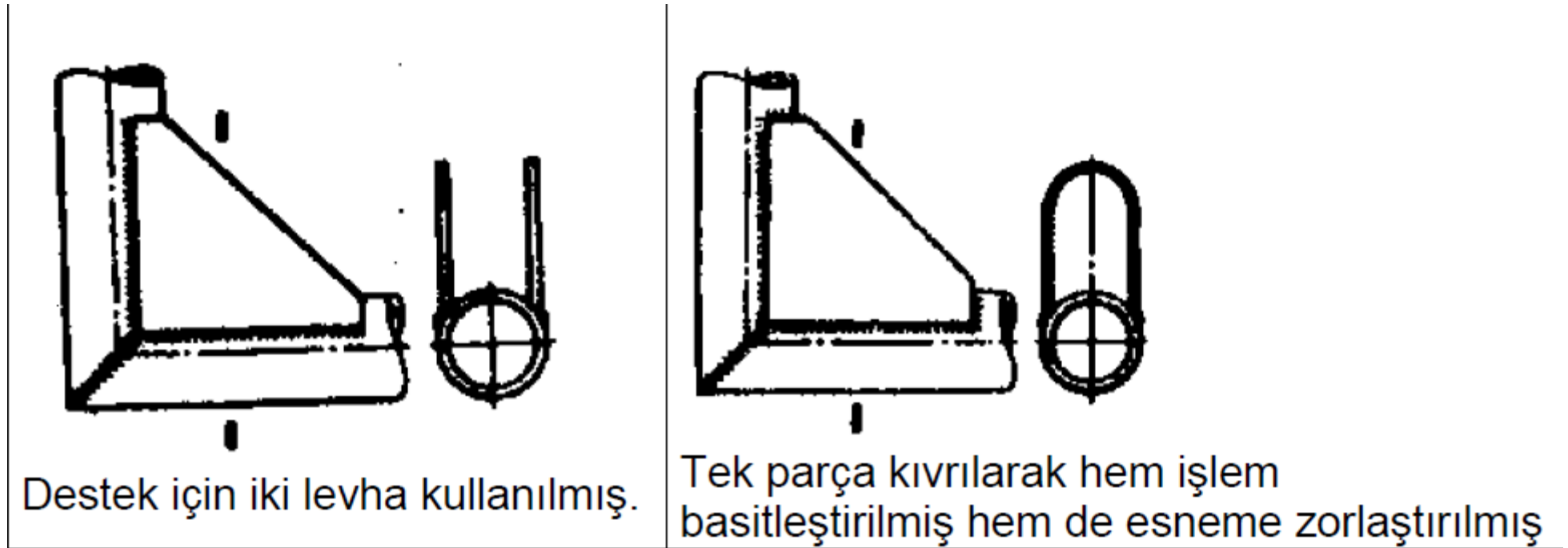

8) Parçaların üretimi basitleştirmeli

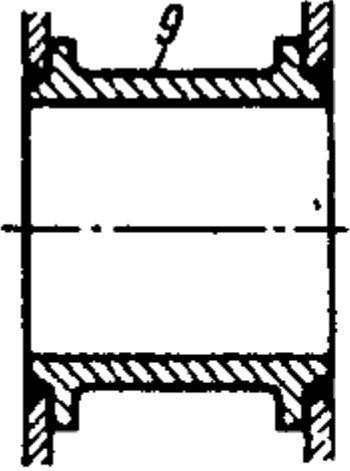

Torna ile şekillendirilmiş parça kullanılmış.

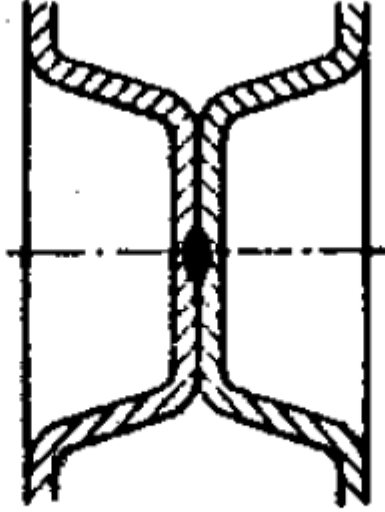

Torna ile işlenecek parça yerine presle daha kolay şekillendirebilecek tasarım

8) Parçaların üretimi basitleştirmeli

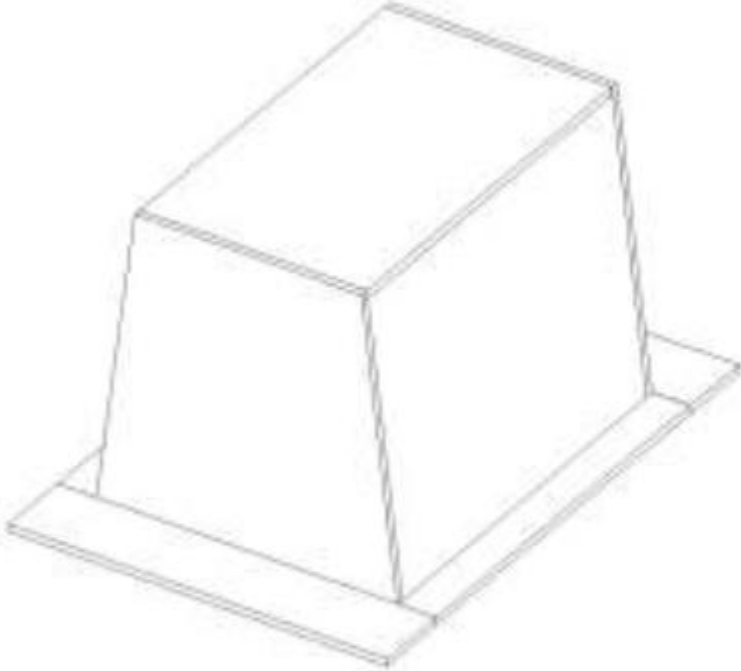

Dokuz adet parça kesilerek kaynatılmış.

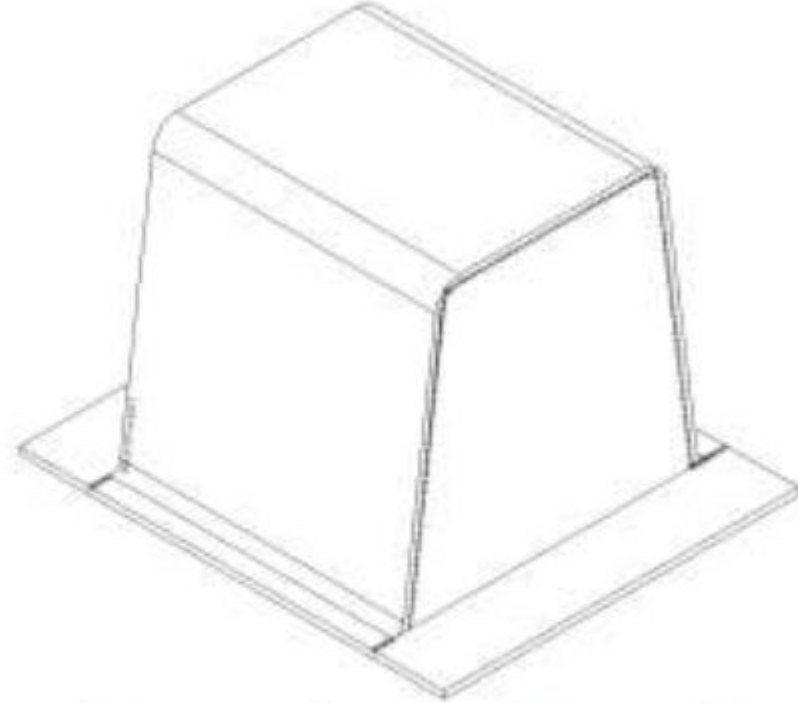

Üç adet parça kıvrılarak kaynatılmış.

