



Ankara Üniversitesi
Ziraat Fakültesi
Peyzaj Mimarlığı Bölümü



PEYZAJ YAPILARI

TARIMSAL İŞLETMELER VE ÇİFTLİK YAPILARI

ÇİFTLİKLERİN GENEL ÖZELLİKLERİ

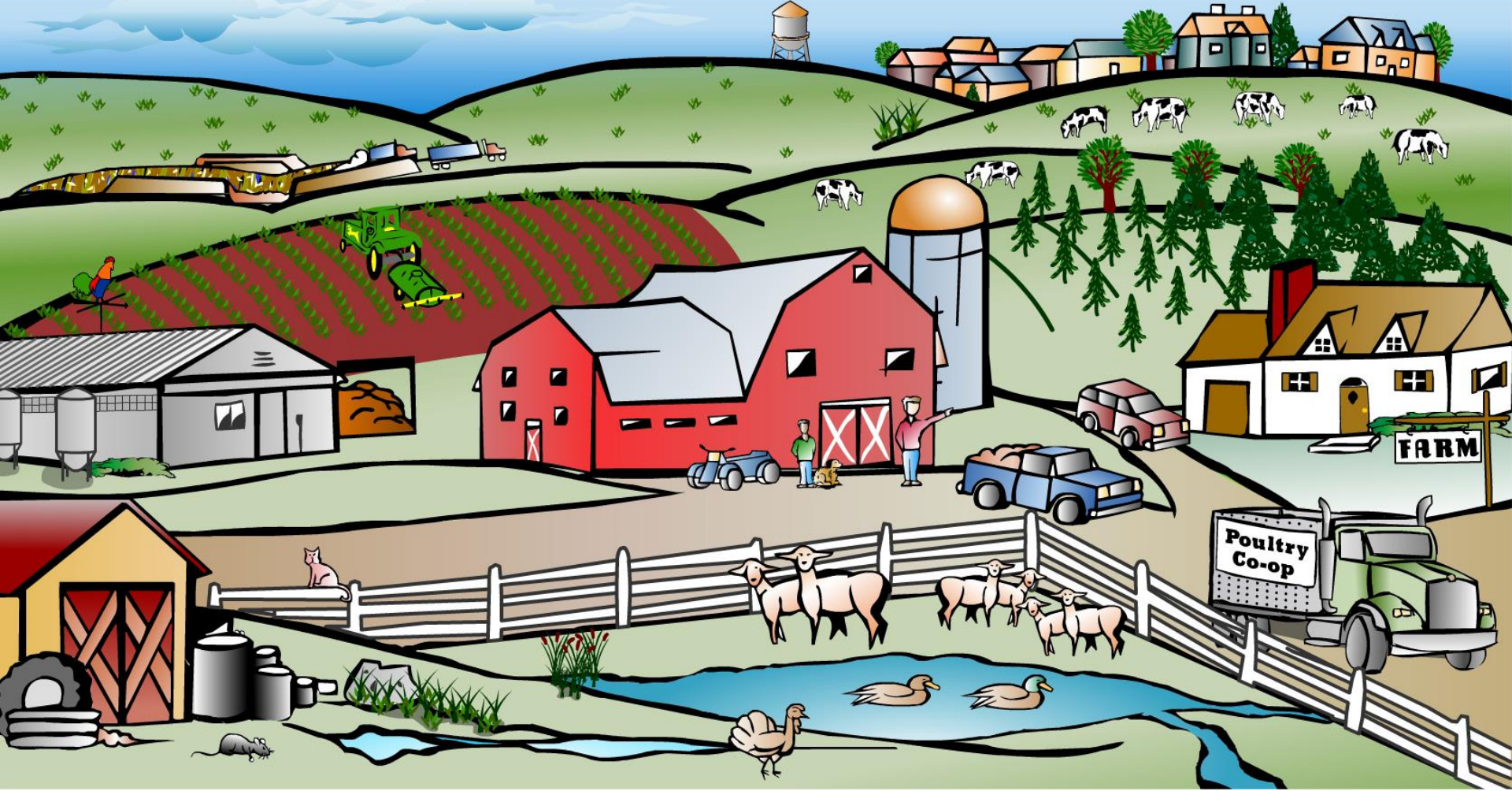

- 
- Tarımsal işletmeler ve çiftlikler, tarımsal üretimin gerçekleştirildiği, her türlü evcil hayvanı yetiştirmeye uygun olan ve bu işleri yürütmek üzere çalışanların barınmaları için de tesislerin bulunduğu tarım alanlarıdır

- Çiftlikler yada tarımsal işletmeler işlev ve niteliklerine göre ikamet binası/binaları, ahır, ağıl, kümes, at barınakları, ot ve yem depoları, ambarlar, sera, servis birimleri ve benzeri tesislerden oluşmaktadır.

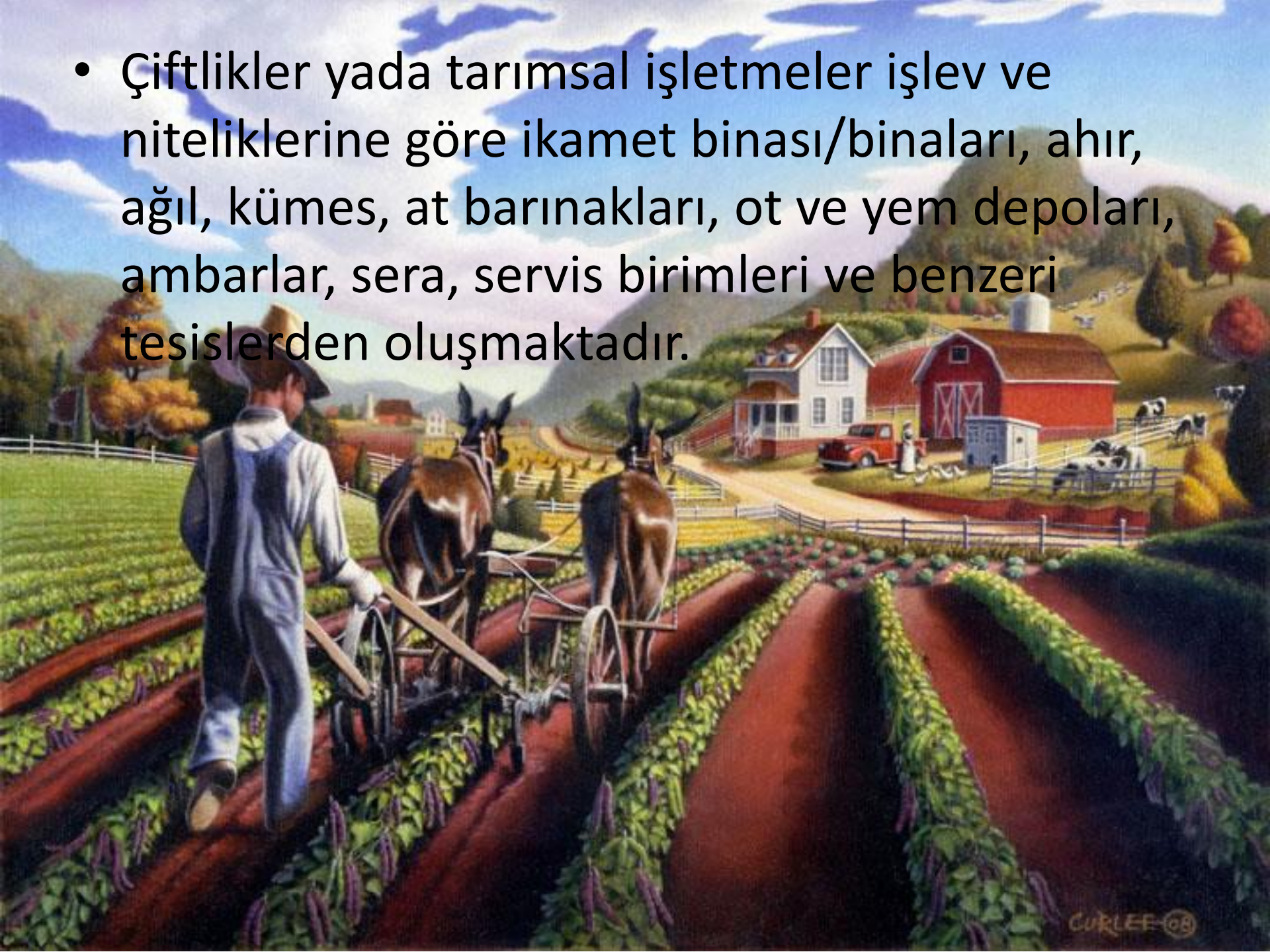

- Çiftlik ve tarımsal işletmelerin bir diğer önemli özelliği kırsal alanda yer almalarıdır.

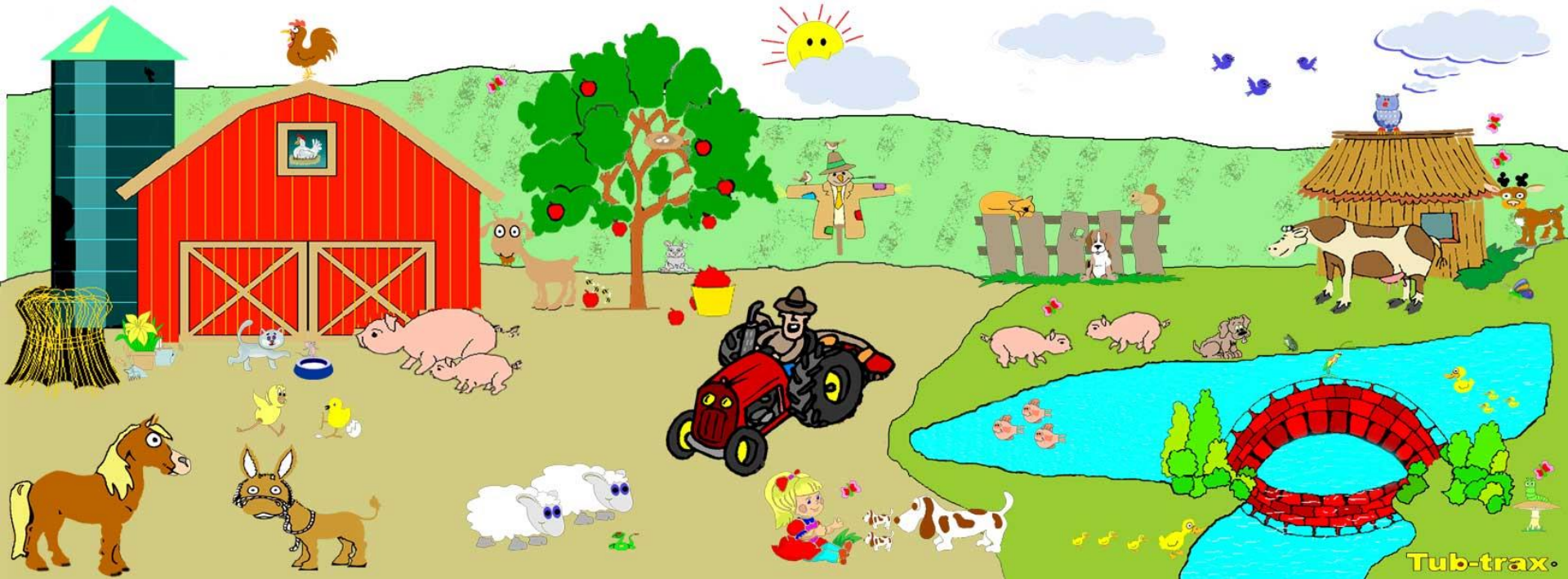



- Çiftlik tesisleri mümkün olduğu kadar geniş arsalar şeklinde tasarlanmalıdır





- Çiftliklerde, konut + bahçe 1000 m² olmalı, işletme yapıları, ahırlar, kümesler, avlular, otlaklar ile entegre tasarlanmalıdır.



- El arabaları için %5 eğim
- Motorlu taşıtlar için %10 eğim
- Kısa mesafeli kullanımlar için %20 eğimli (en fazla) olacak biçimde tasarlanmalıdır. (Neufert, 2000)









ÇİFTLİK EVLERİ





- iftliklerde yařayan ailelerin ya da personelin barınması için ikamet yapılarına gereksinim vardır. iftlik evleri bulunduğu kırsal ortama uygun malzeme, form ve biçim özellikleri ile insan ölçüğünde tasarlanmalıdır.







KÜMESLER



- Tavuk, ördek, kaz, hindi gibi hayvanların barındığı mekanlara; küçük, kanatlı hayvan barınaklarına kümes denmektedir.



Kümeslerin sahip olması gereken bazı özellikler:

Chicken Brooder Coop and Run

- Hayvan bakımına elverişli ortamın sağlanmış olması gerekmektedir,
- Temiz, kuru, aydınlık, ısı yalıtımlı, havalandırılmalı ve hava koşullarına dayanıklı olmalıdır,
- Parazit ve mikropların barınmasına ve gelişmesine elverişli olmamalıdır,
- Yem hazırlama, depolama vb. kullanımlar için yan odalar/mekanlar tasarlanmalıdır,
- Kümesin biçimi güneş durumuna uygun olarak planlanmalı, pencereler mümkün ise güneyde, giriş/kapı ise doğu yönünde konumlandırılmalıdır,
- Pencere yüzeyi kümes yüzeyinin en çok %10'ü oranında olmalıdır,
- Yumurtlama bölümü kümesin en karanlık yeri olarak tasarlanmalıdır,

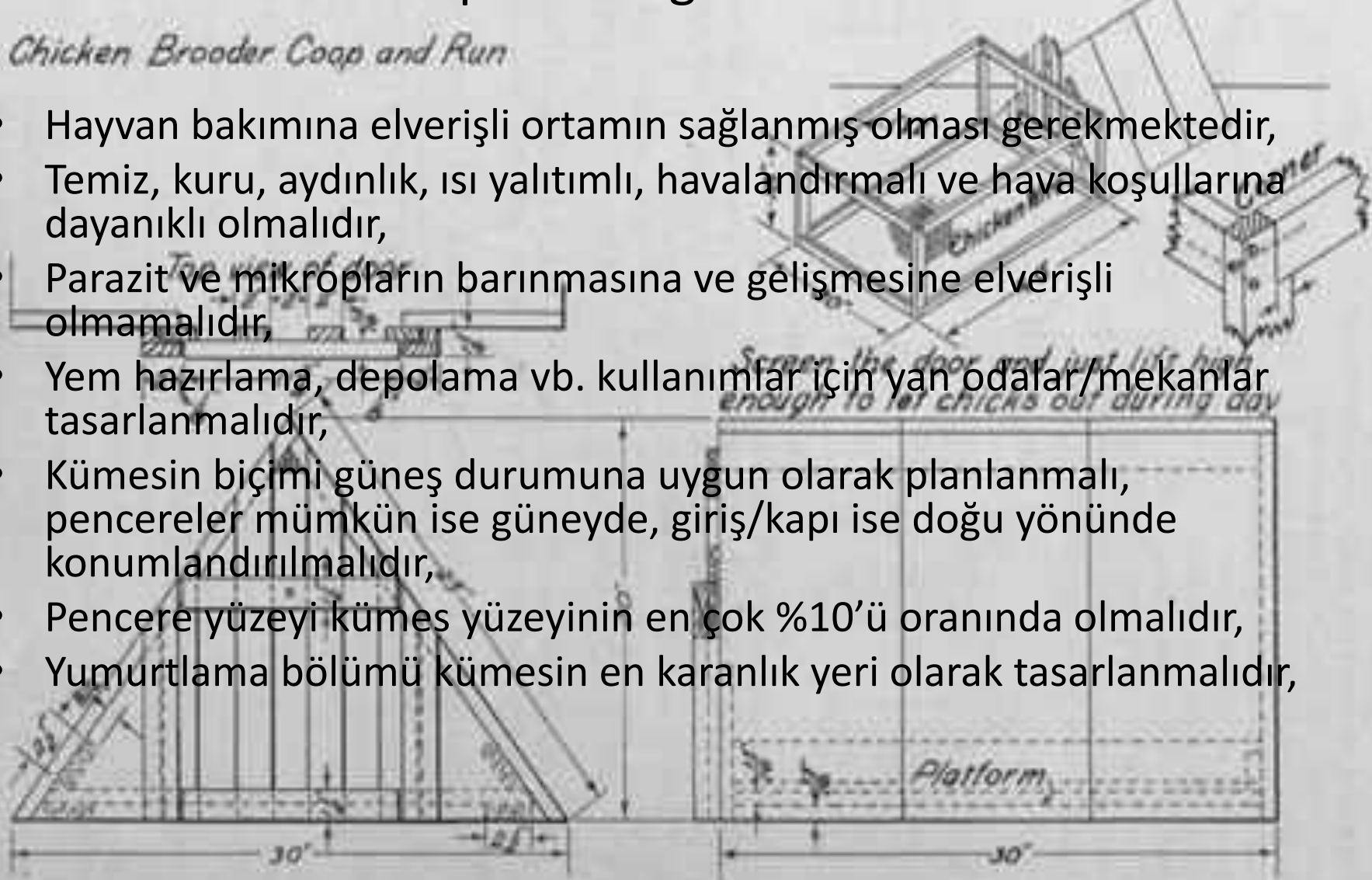









AHIRLAR





- Büyükbaş hayvan ahırları iki grupta değerlendirilmektedir. Bunlar bağlama ahırları ve kabin ahırlarıdır.

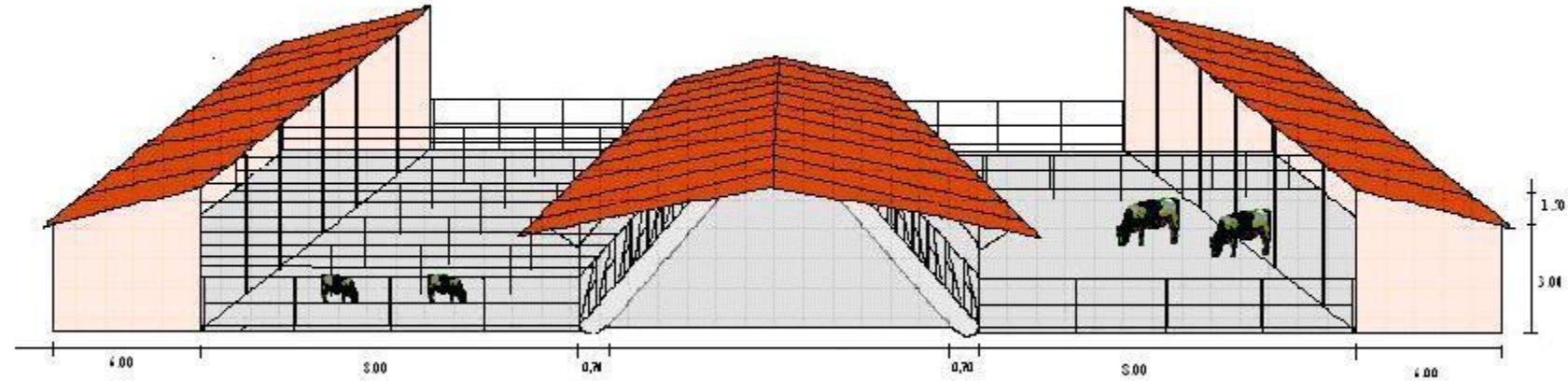

Örnek Ahır Binası





- Ahırlar yapısında saman depoları bulundurmaktadır.



RÜZGAR FIRILDAKLARI



Genellikle Amerikan çiftliklerinde sık rastlanan, yapı üzerine veya bir direk üzerine bağımsız konan bir rüzgar yönü ölçme aletidir.



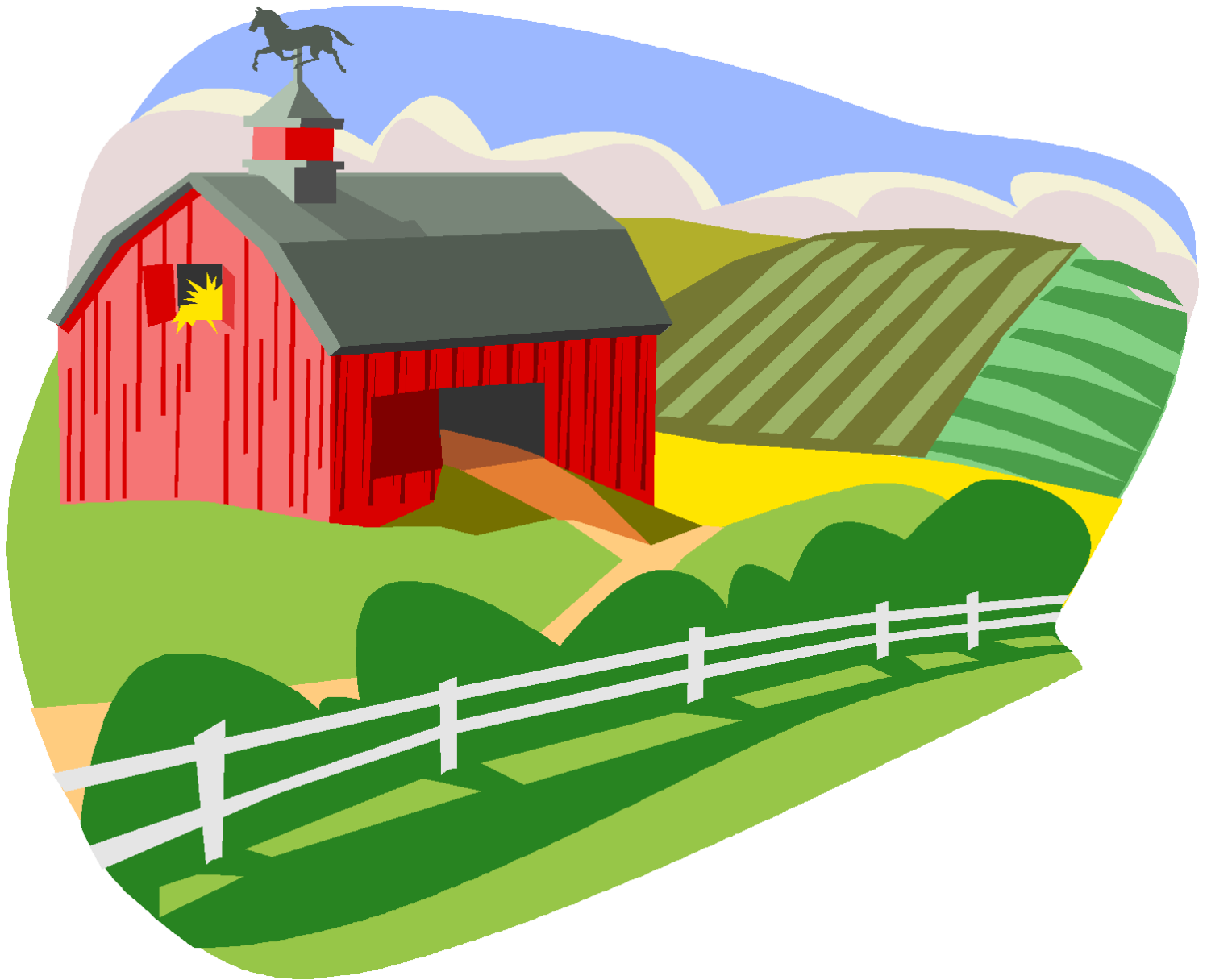



FSV-2602



FSV-2603



FSV-2604



FSV-2605



FSV-2601



FSV-2606









CEK
Carpenter's Heritage



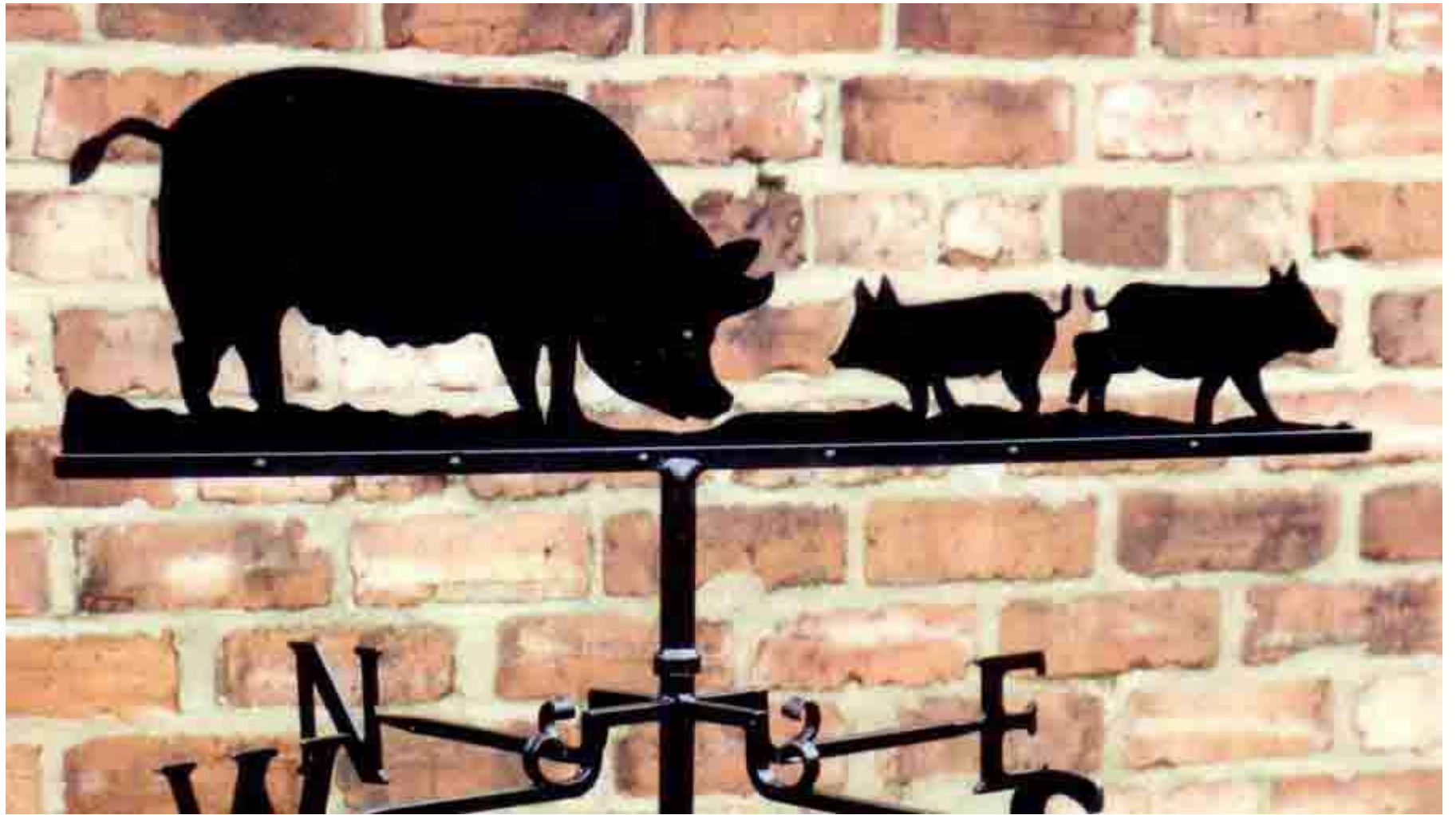









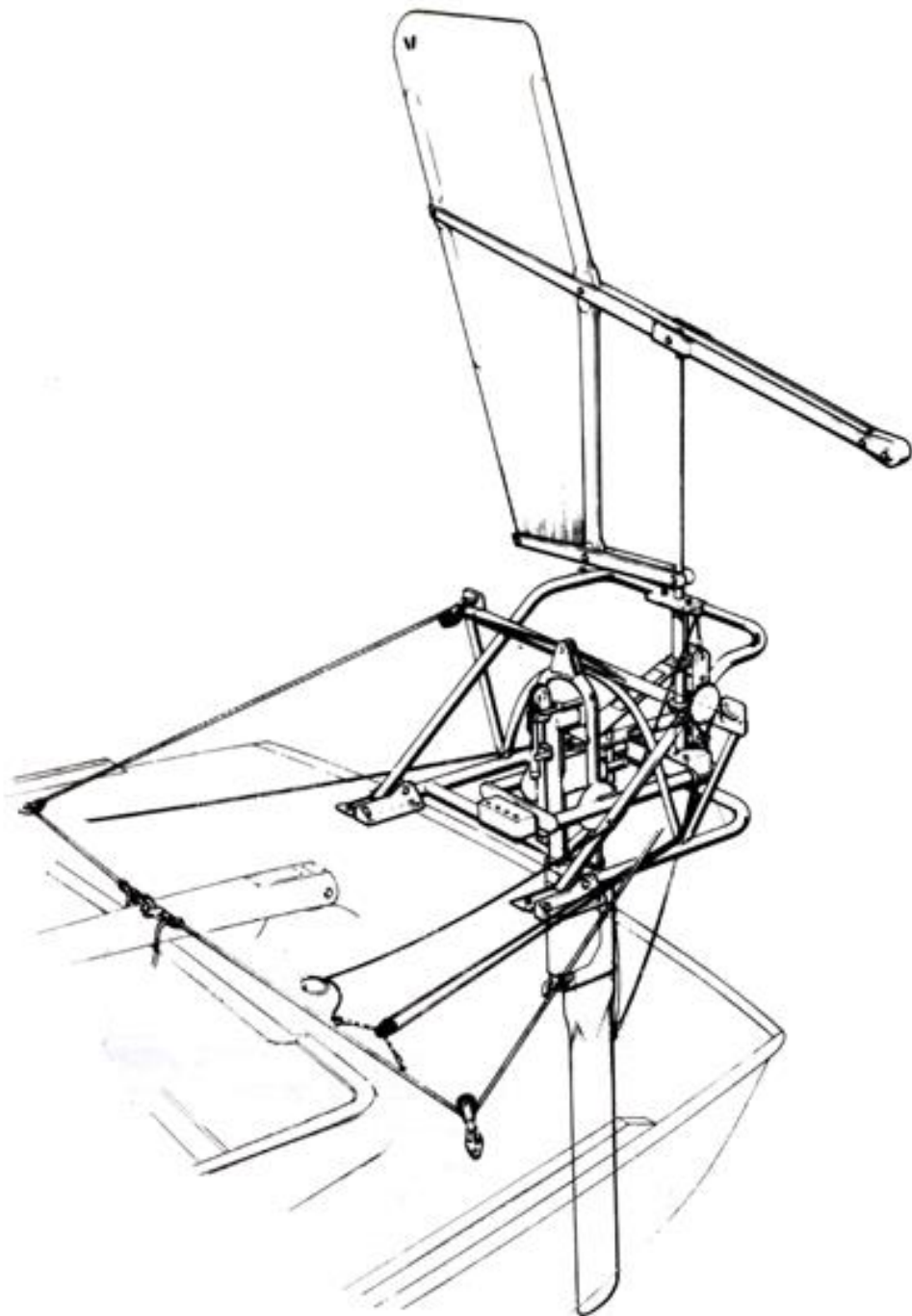

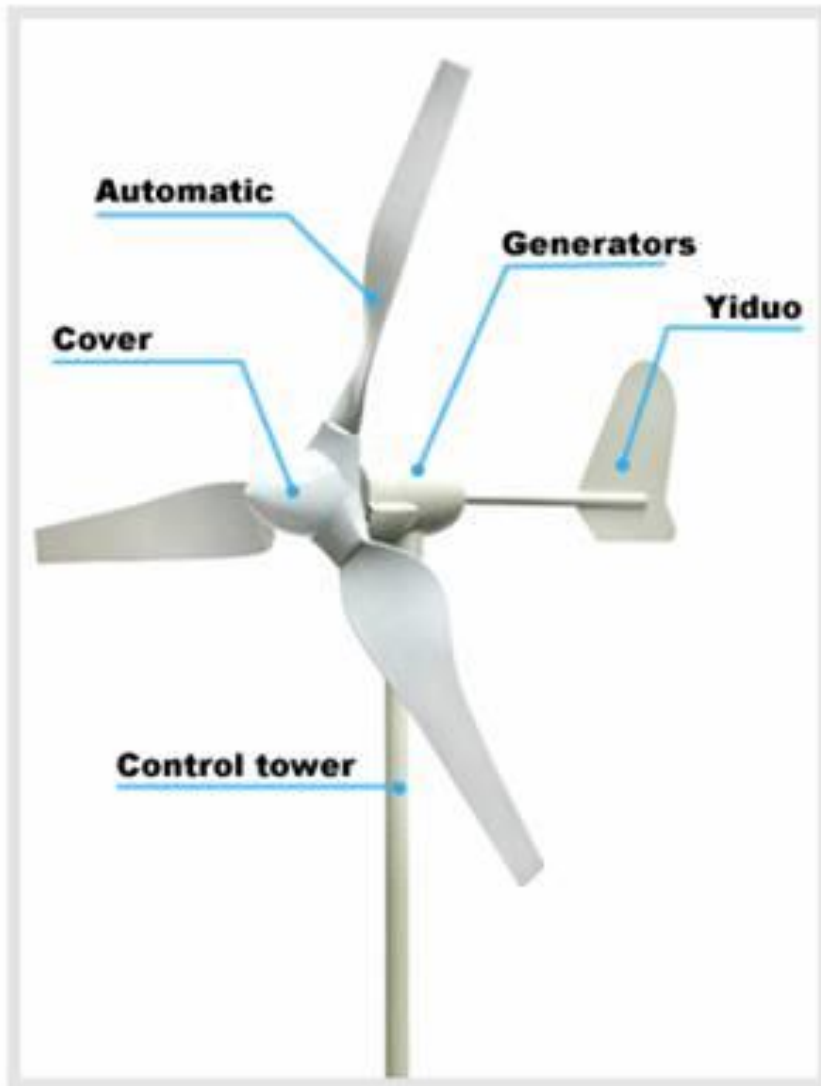

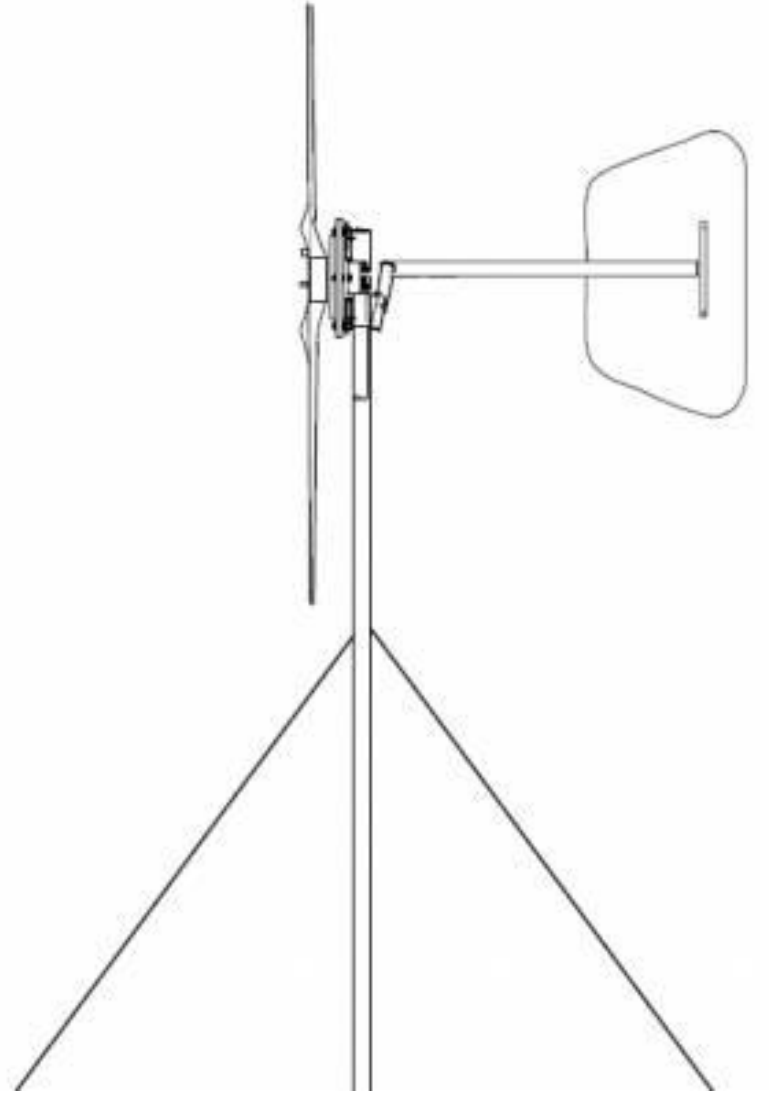
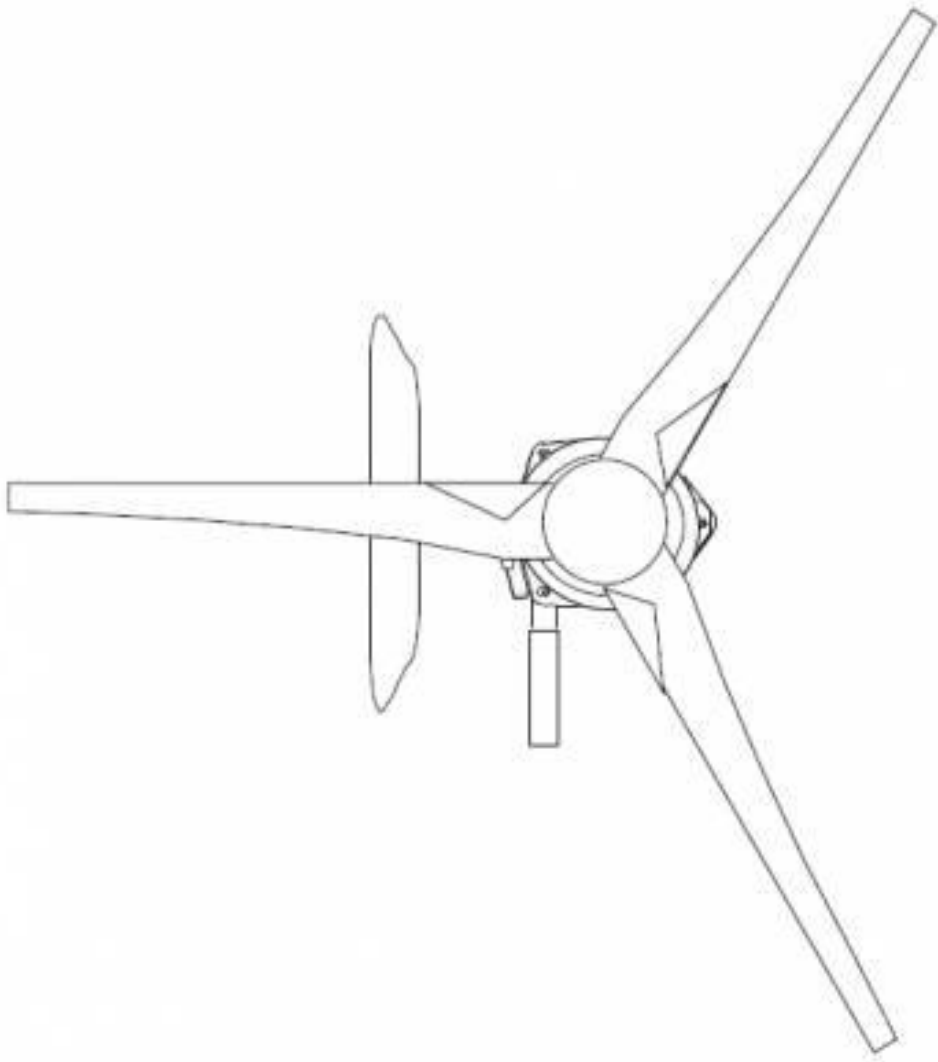











KUYULAR



Genellikle Rusya iftliklerinde sık rastlanan bir peyzaj yapısıdır.









Рис. 1—48. Шахтный колодец, выполненный в виде деревянного сруба: грузом для опрокидывания; 5 — ворот; 6 — от- мостка; 7 — щебень; 8 — глиняный замок.



Рис. 1—49. Типы шахтных колодцев.



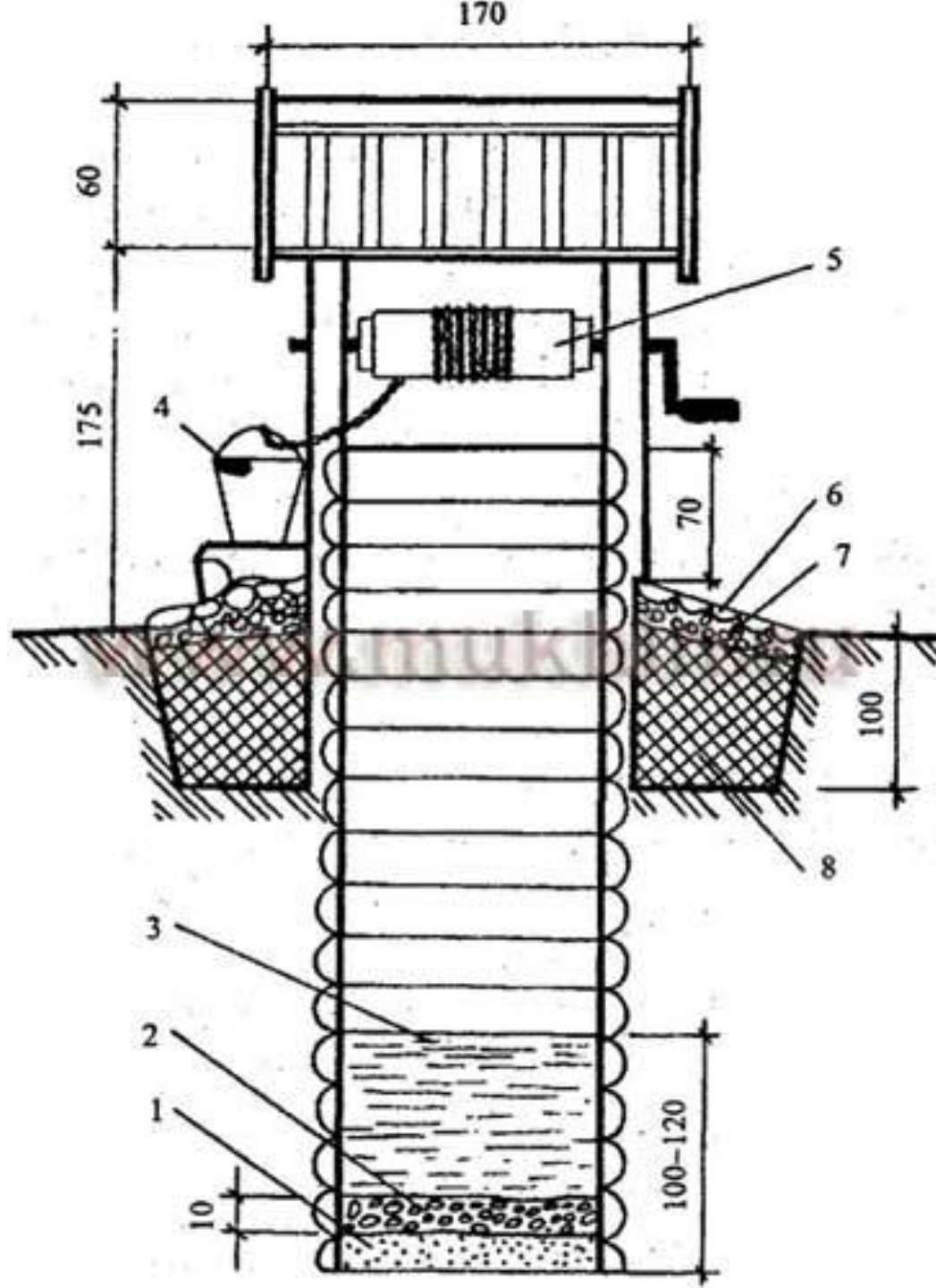



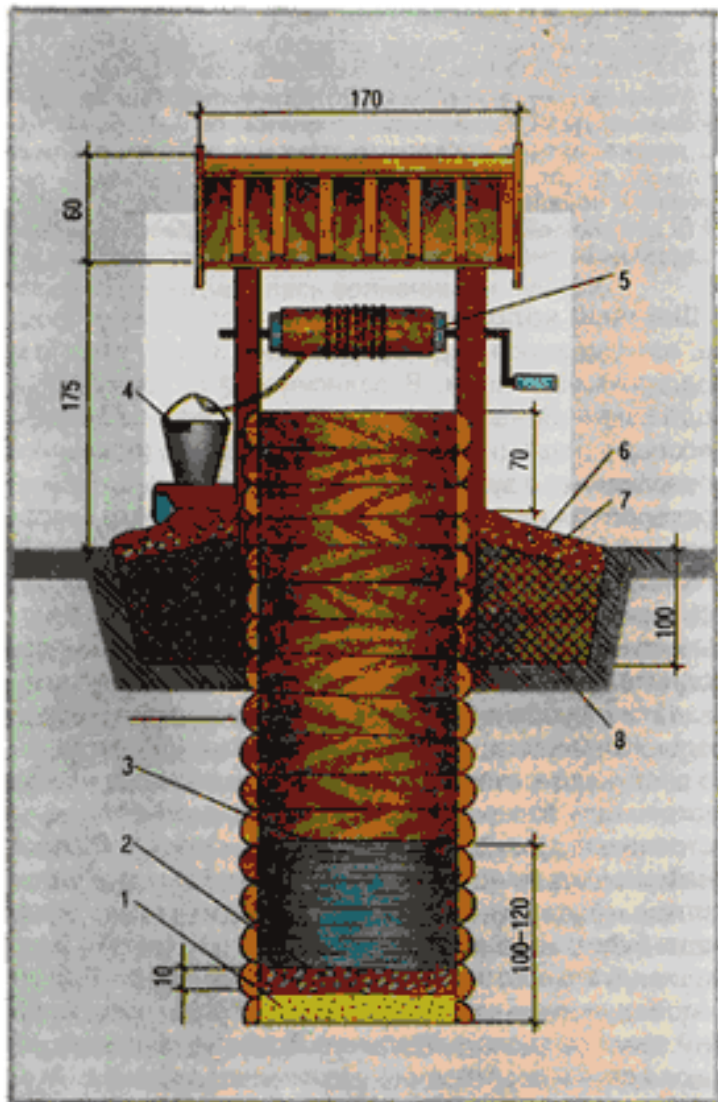
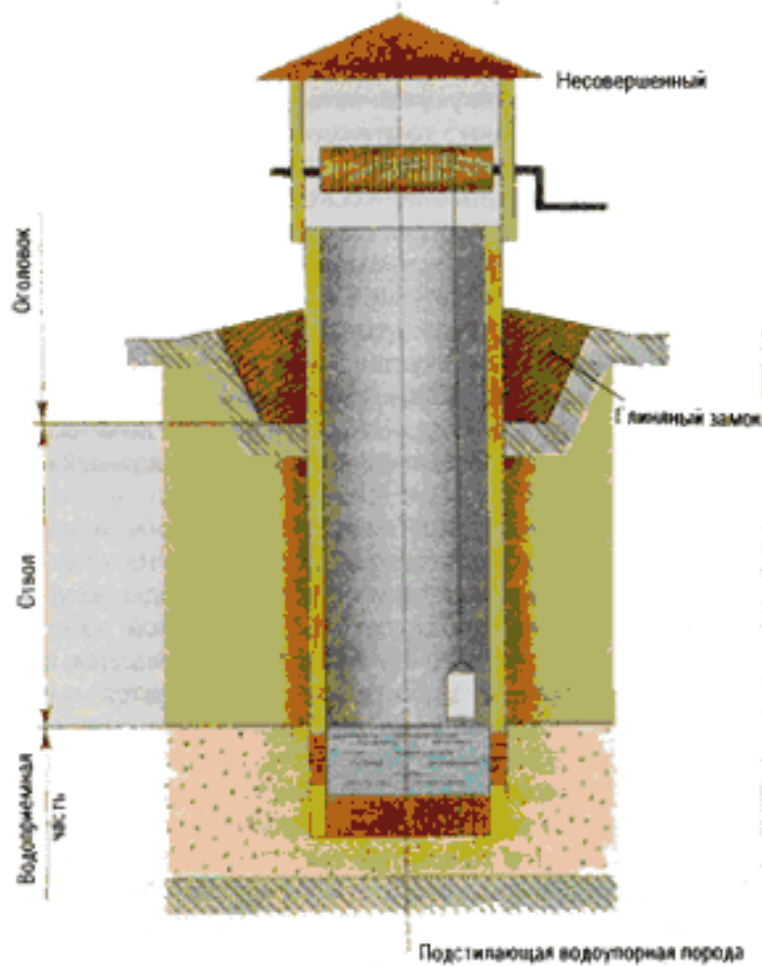
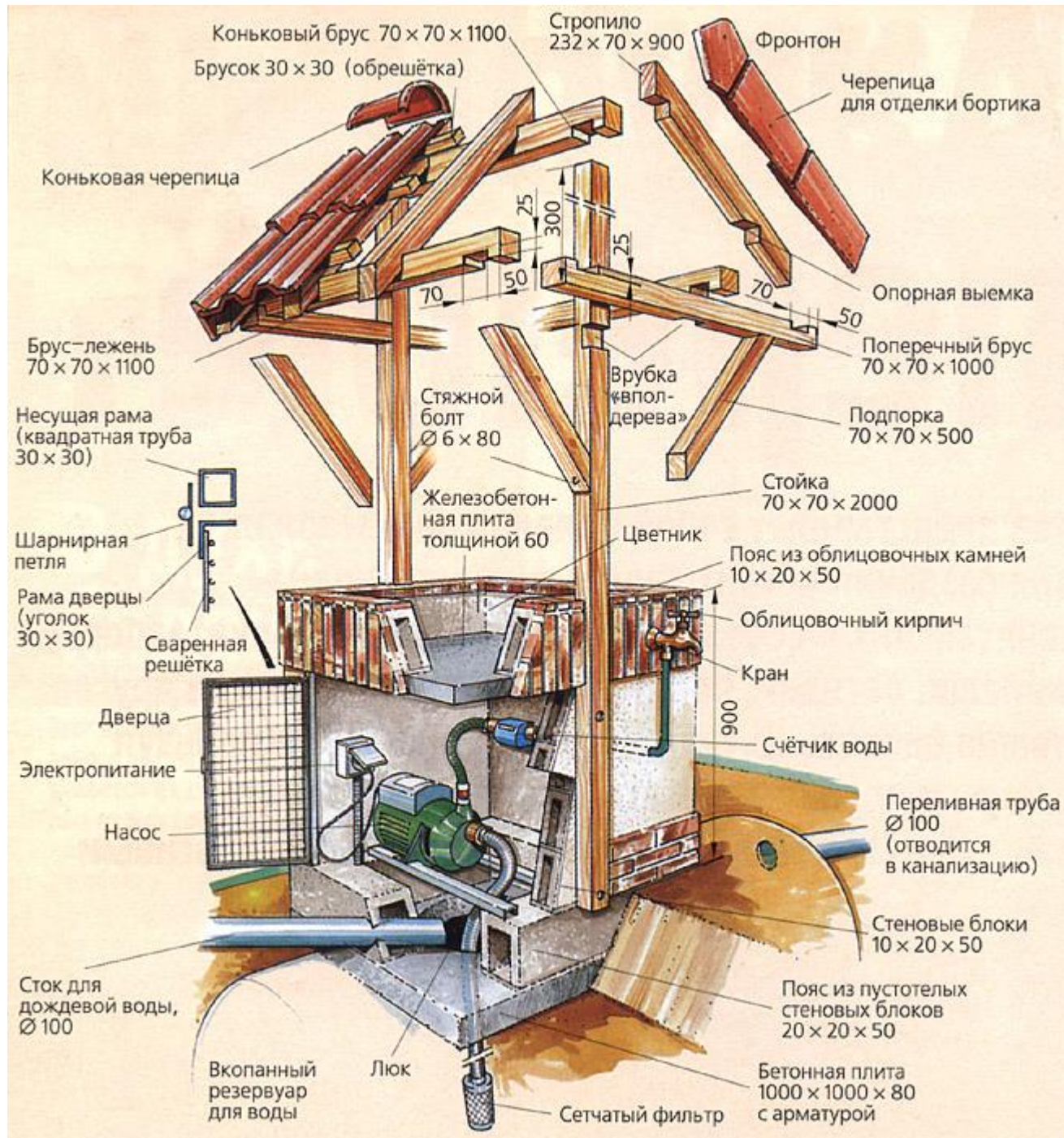
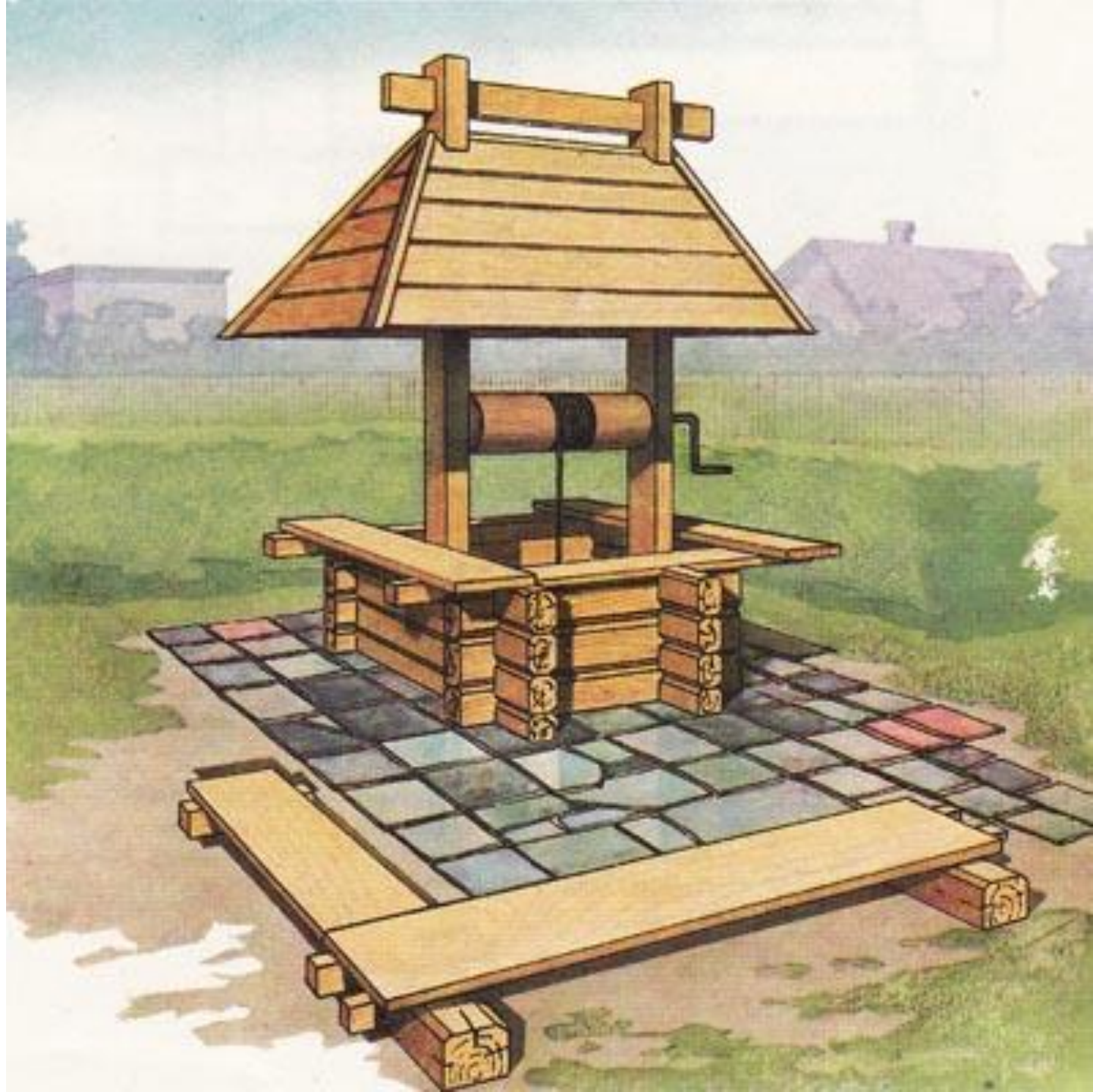





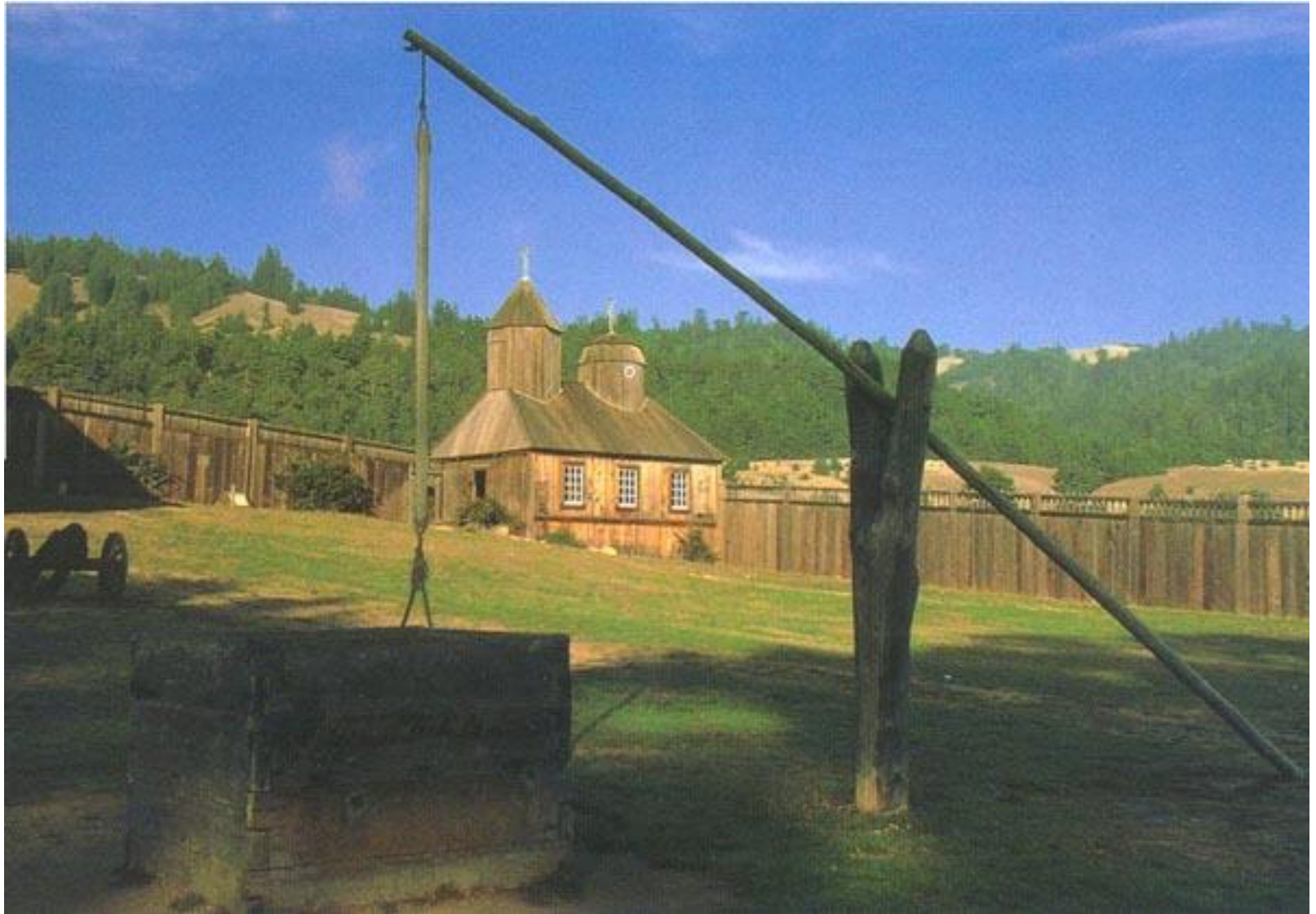



www.besedki.ru









Kaynaklar :

'Peyzaj Yapıları' E. Erdoğan L. Erdinç 2009

<http://www.commons.wikimedia.org>

<http://www.pottsoft.com>

<http://www.gateshead.gov.uk>

<http://www.metoffice.gov.tt>

<http://www.pbs.org>

<http://www.ftschooll.org>

<http://www.kolodes.ru>

<http://www.chickencoopplans4u.com>

<http://www.urbanchickens.org>

<http://www.allthecreatures.today.com>

<http://www.claire-cameron.com>

<http://www.greenterrafirma.com>

TEŞEKKÜRLER