

Aeol Düzeni MÖ 7. yy sonu – MÖ 6. yy

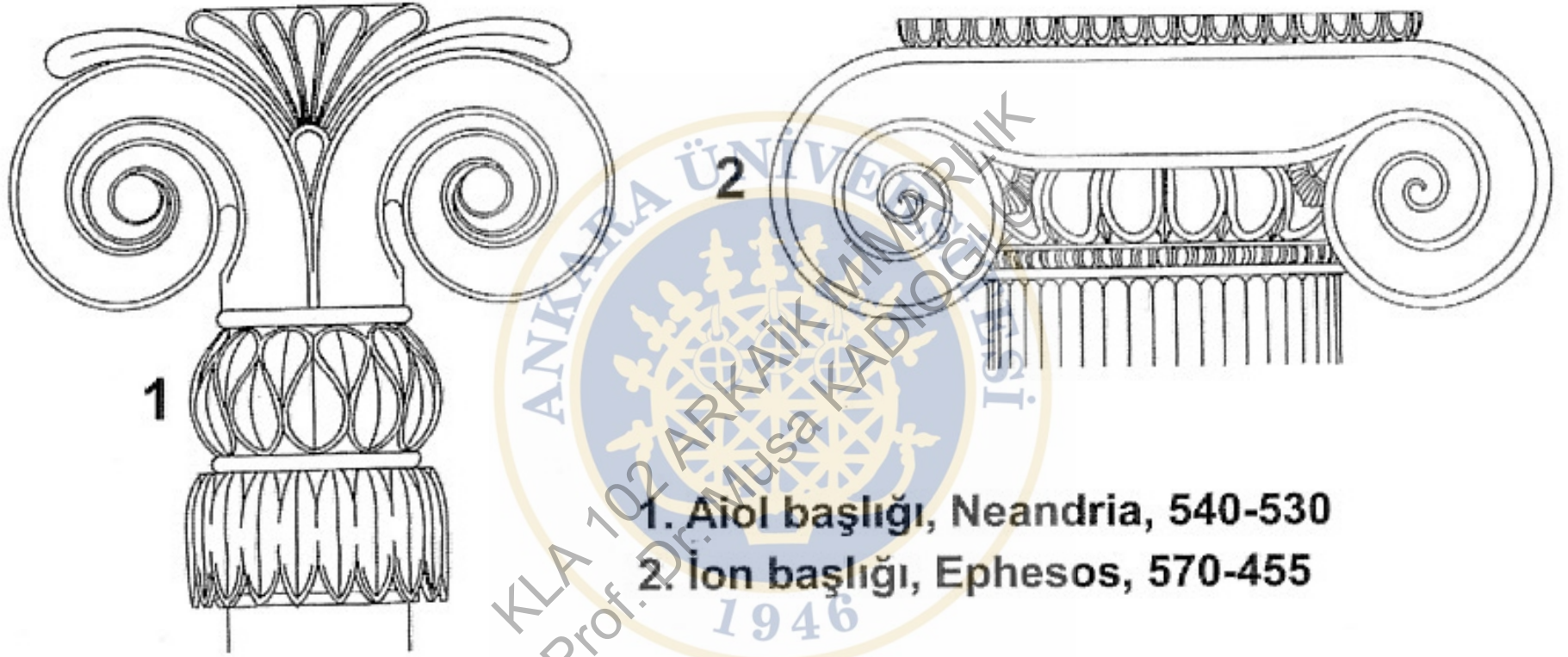

1. Aiol başlığı, Neandria, 540-530

2. İon başlığı, Ephesos, 570-455

Fig.IV.98. Aiol ve İon başlıkları (Schmidt-Colinet 2004: 41)

Arkaik Dönem Tapınakları

Anıtsal Hellen Mimarlığına Giriş

Yaprak Eran

Y. Eran, Arkaik Dönem Tapınakları. Anıtsal Hellen Mimarlığına Giriş (İstanbul 2018) 438-447



1. Smyrna Athena Tapınağı (MÖ 600-580)
2. Neandria Tapınağı (MÖ 6. yüzyıl)
3. Troia Arkaik Tapınak (MÖ 550)
4. Klopedi Tapınağı, Lesbos Adası, MÖ 6. yüzyılın ikinci yarısı

Dor ve İon Düzeni



Dorisches Kapitäl mit Gebälk.



Ionisches Kapitäl mit Gebälk.

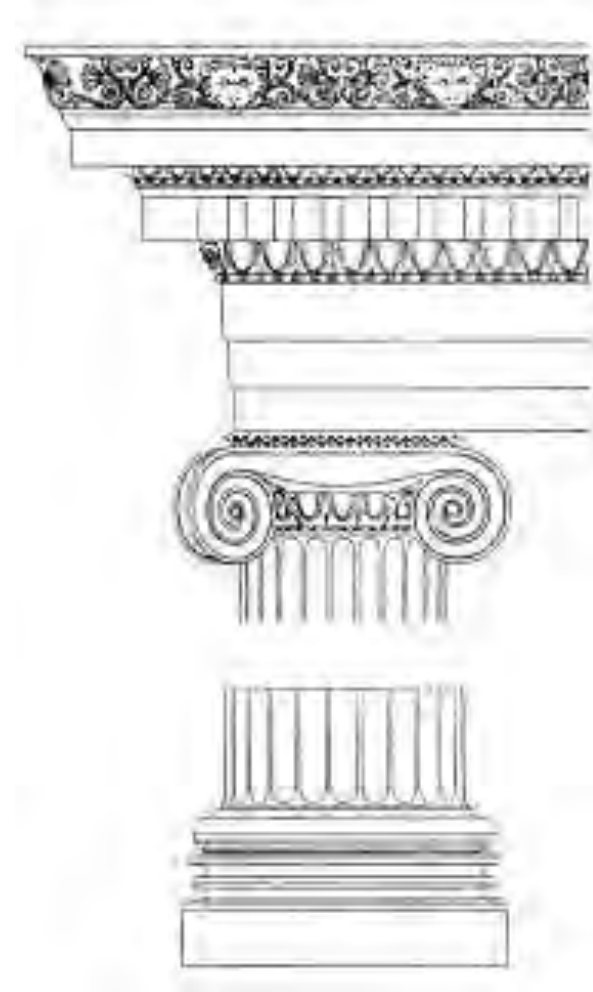

Aeolis/Aiolis Bölgesi'ndeki 12 Aiol kenti:

- 1-Kyme (Aliğa –Nemrut Koyu)
 - 2-Larisa (Buruncuk Köyü)
 - 3-Neontheikos (Yanıkköy)
 - 4-Temnos (Görece-Kayacık Tepesi)
 - 5-Killa (Zeytinli Köyü yakını?)
 - 6-Notion (Ahmetbeyli)
 - 7-Aigiroessa (Kavaklıdere Köyü)
 - 8-Pitane (Çandarlı)
 - 9-Aigai (Köseler Köyü - Nemrutkale)
 - 10-Myrina (Aliğa-Kalabaktepe)
 - 11-Gryneion (Yenişakran)
 - 12-Smyrna (Bayraklı)'dır. Fakat Smyrna daha sonra Ionia'ya dahil olmuştur.
- Troas'taki aiol kentleri
Kebren ve Skepsis

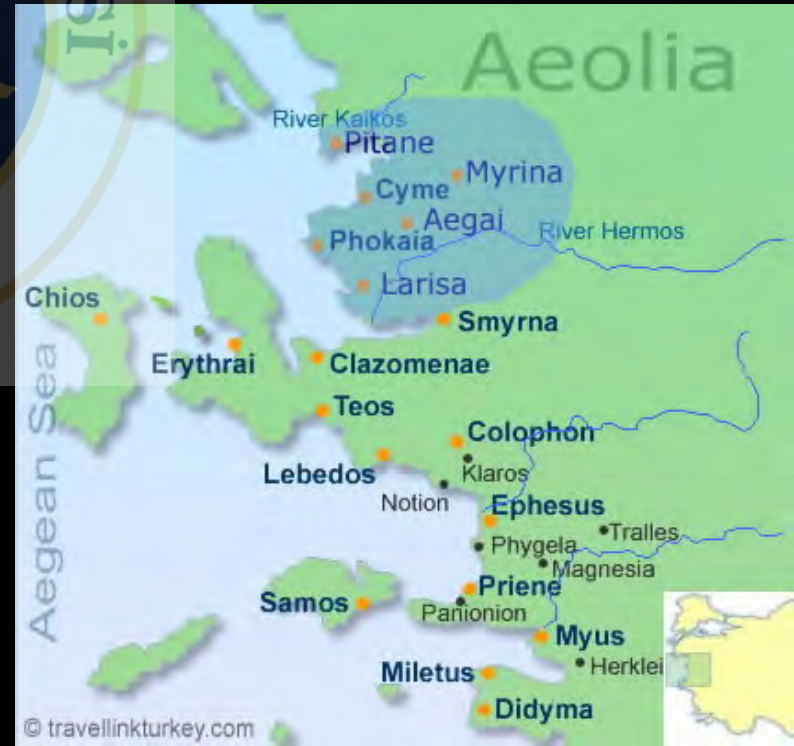
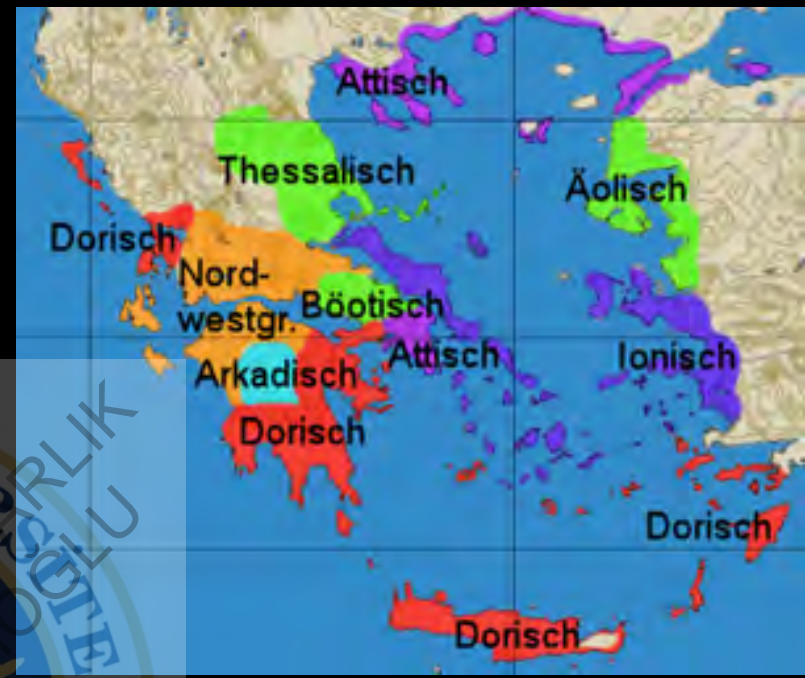

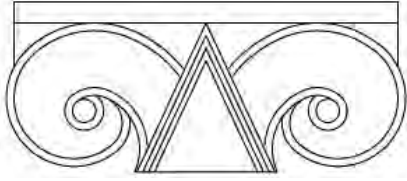

Proto-Aeol



Aeol (proto-Ion)

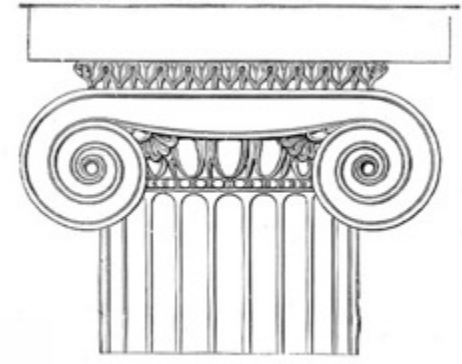

İon sütün başlığı

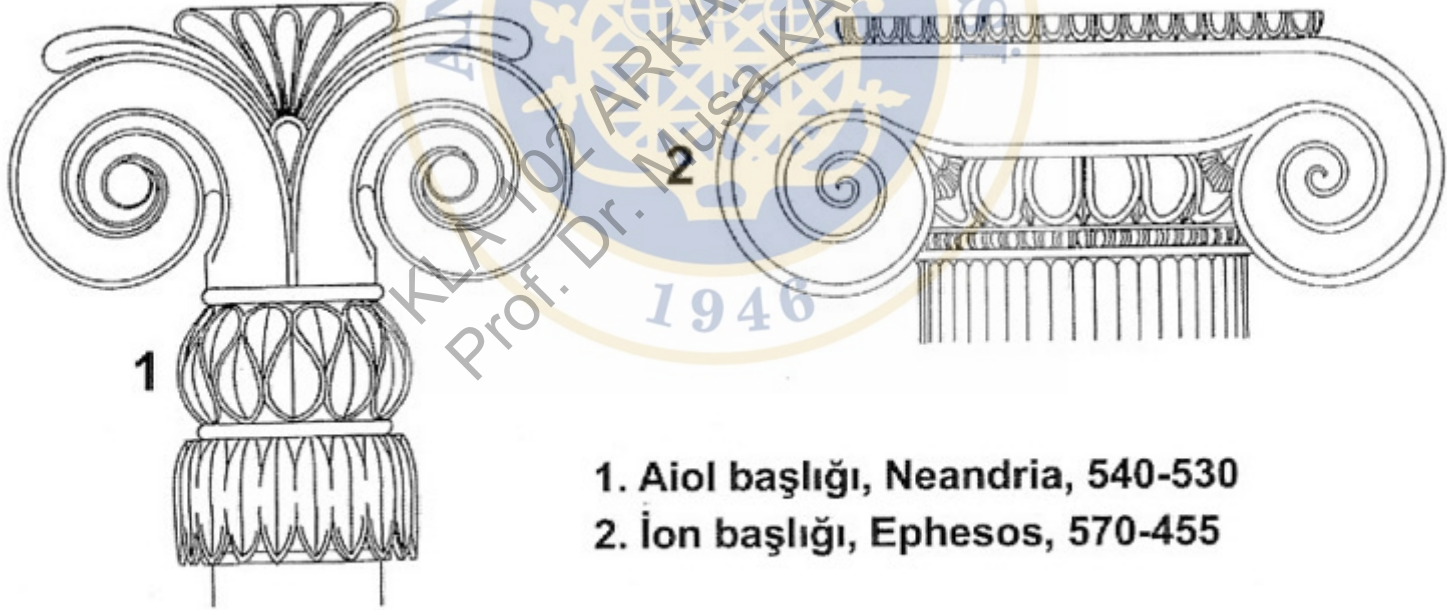

1. Aiol başlığı, Neandria, 540-530

2. İon başlığı, Ephesos, 570-455

Fig.IV.98. Aiol ve İon başlıkları (Schmidt-Colinet 2004: 41)

MÖ 7. yüzyılda Smyrna (Bayraklı/İzmir)

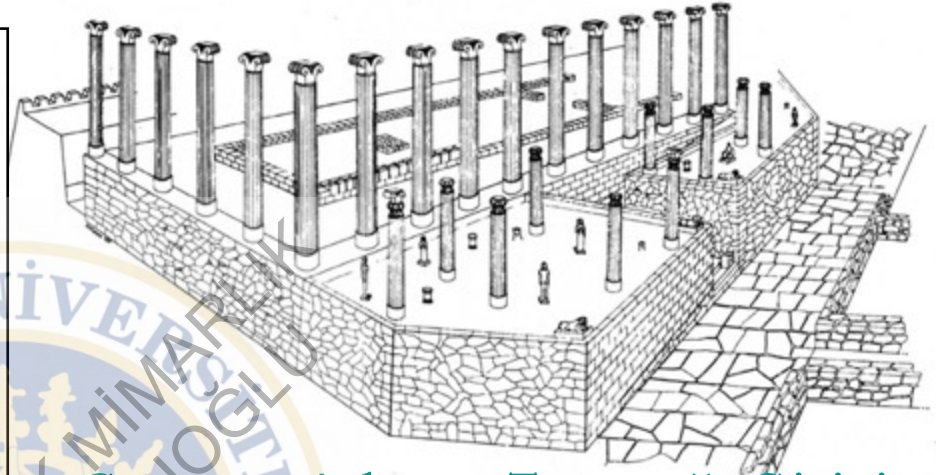
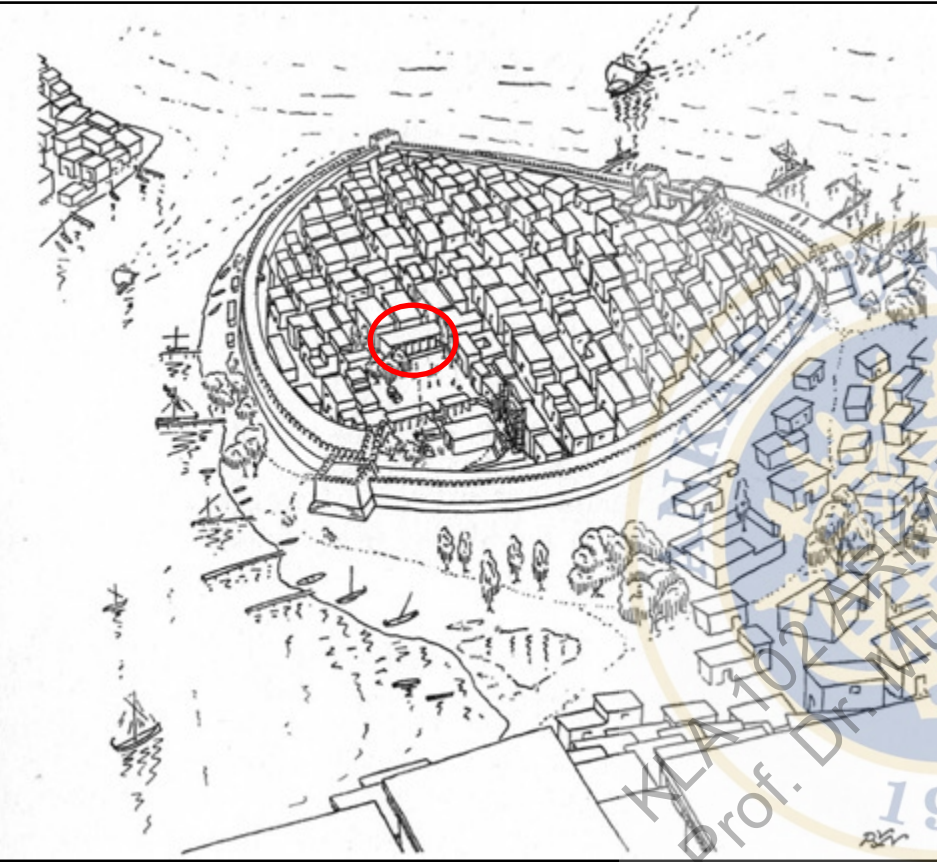

Smyrna Athena Tapınağı Girişi
(MÖ 7. yüzyılın son çeyreği)

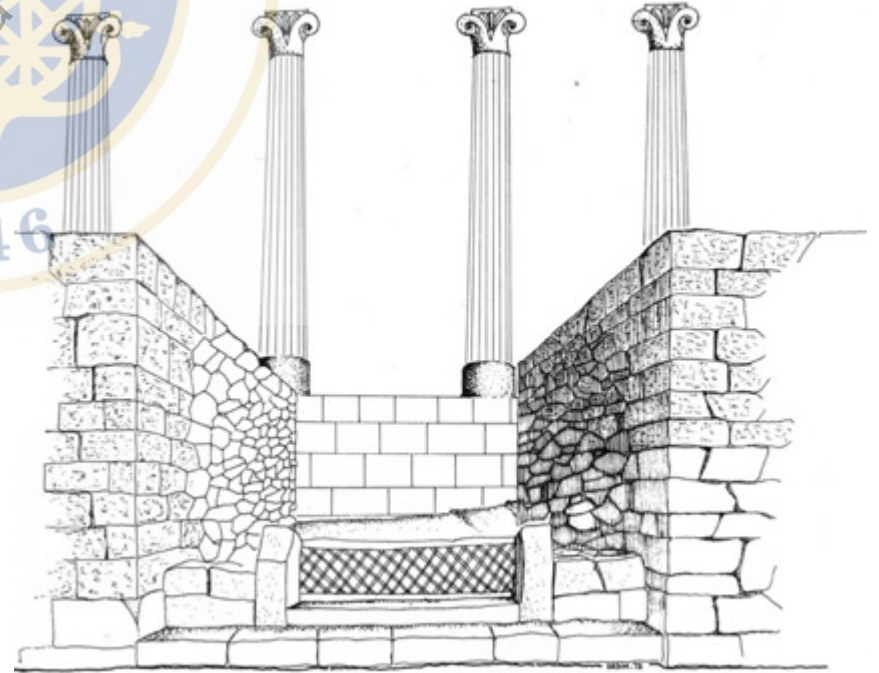

Lesbos Adası, Klopedi Tapınağı (MÖ 6. yy 2. yarısı)



Fig.IV.121. Klopedi Tapınağı'nın günümüzdeki durumu



Fig.IV.122. Klopedi Başlığı

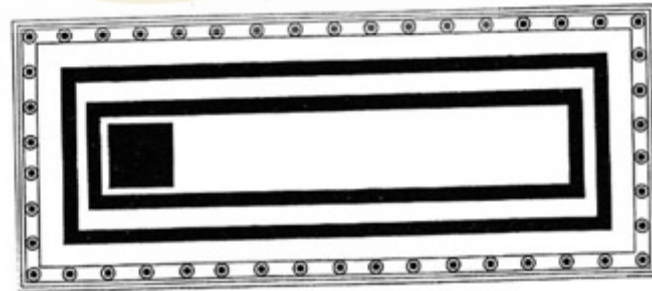
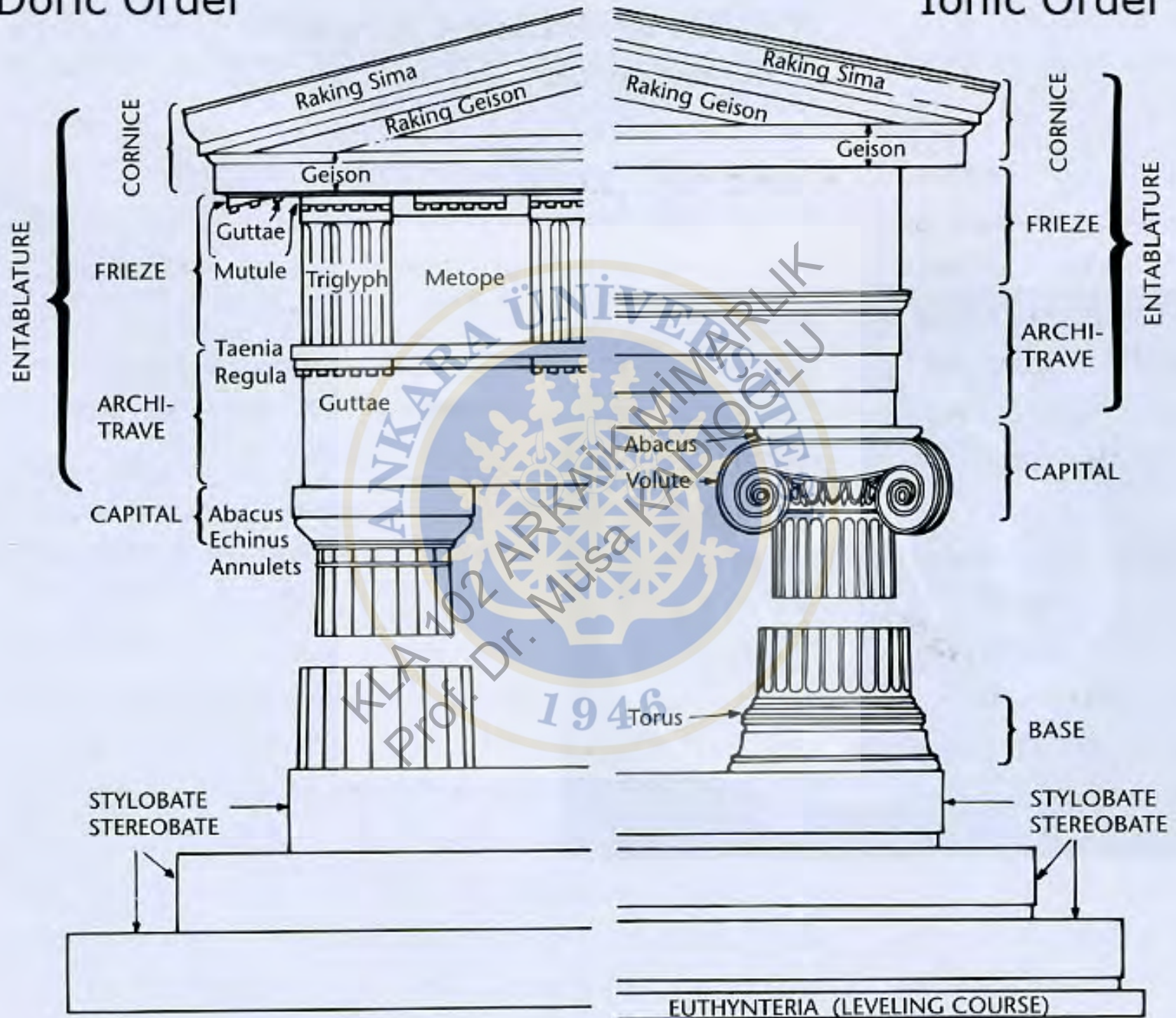

Fig.IV.120. Klopedi Tapınağı, plan
(Betancourt 1977: Fig. 40)

Doric Order

Ionic Order



Smyrna Athena Kutsal Alanı

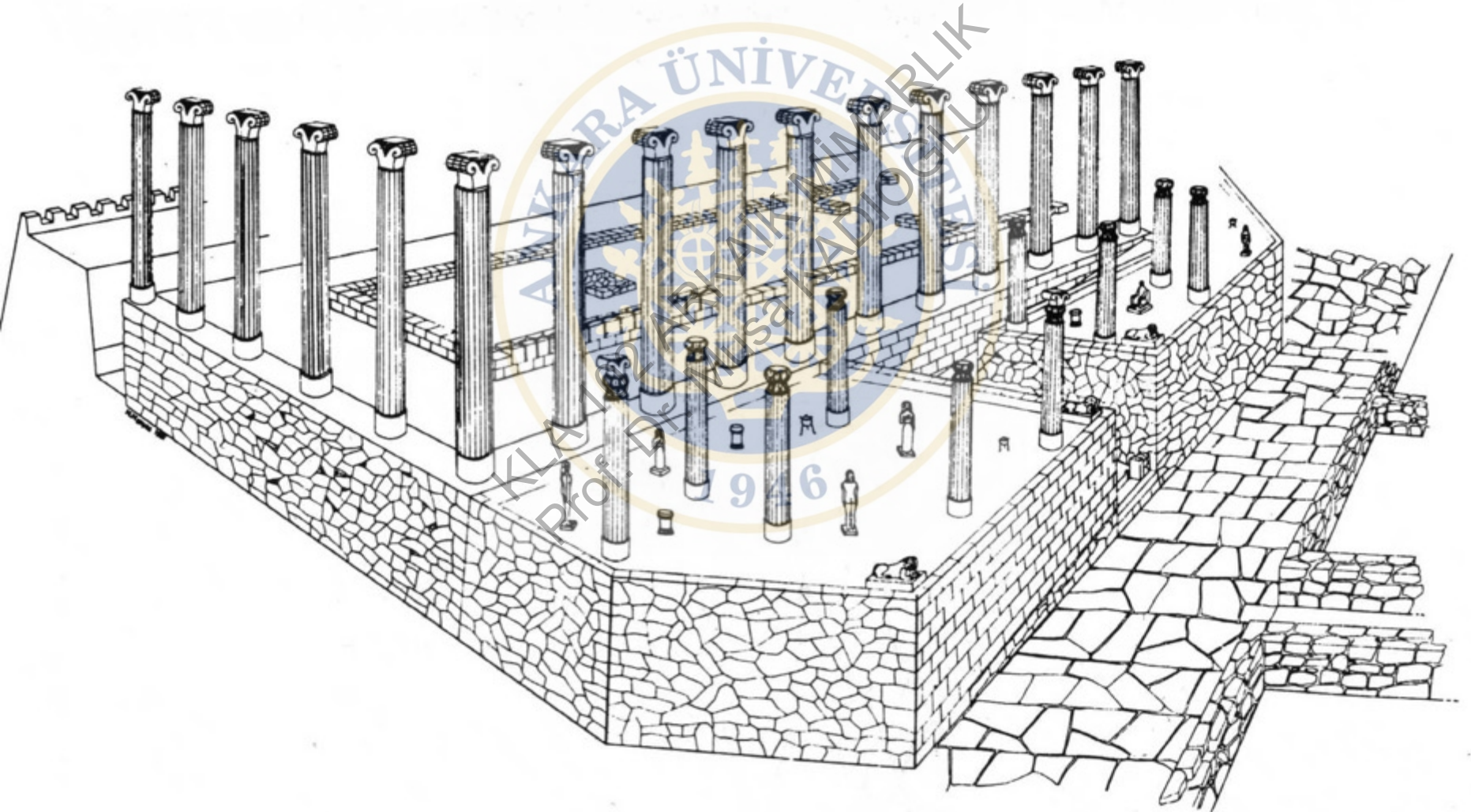

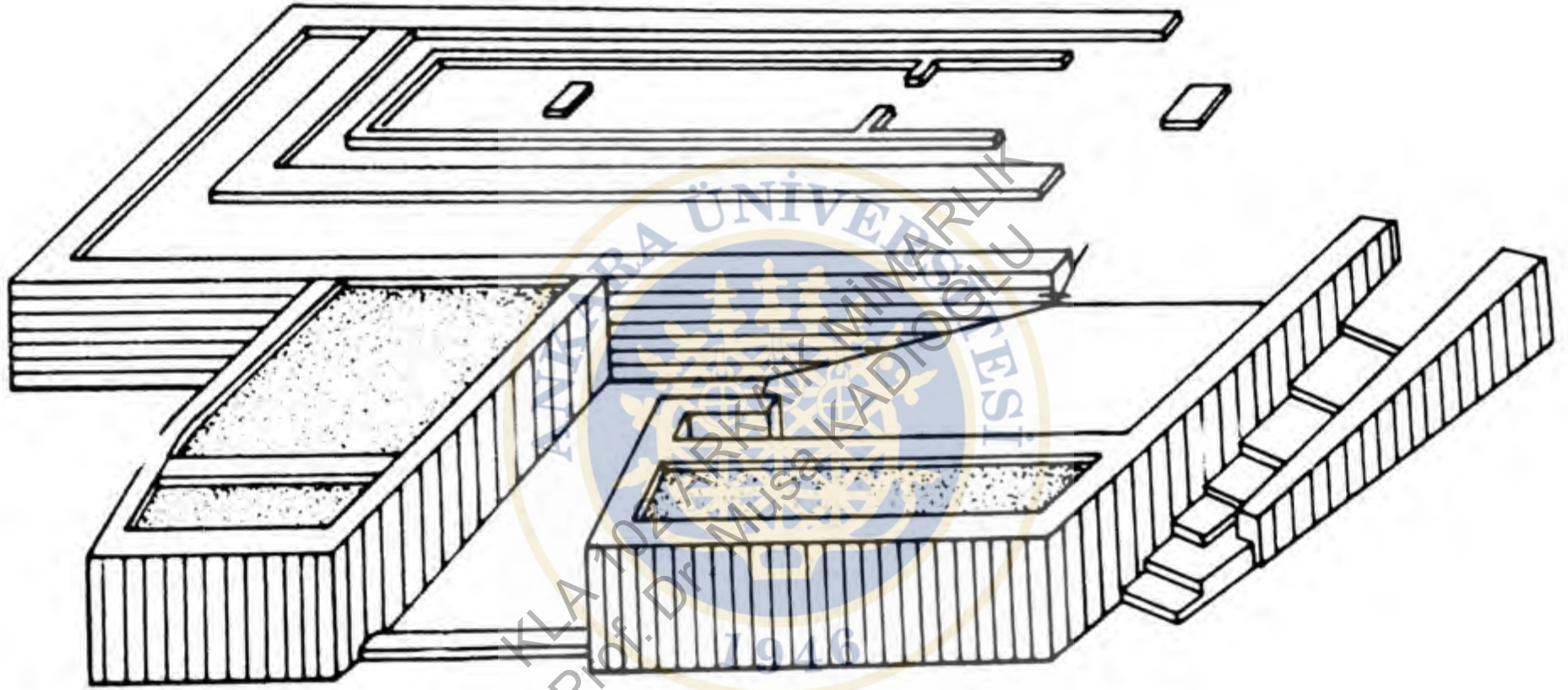

Res. 5 Smyrna Athena Tapınağı. Doğu ve Batı teraslar.
MÖ 7. yüzyıl son dördlük.

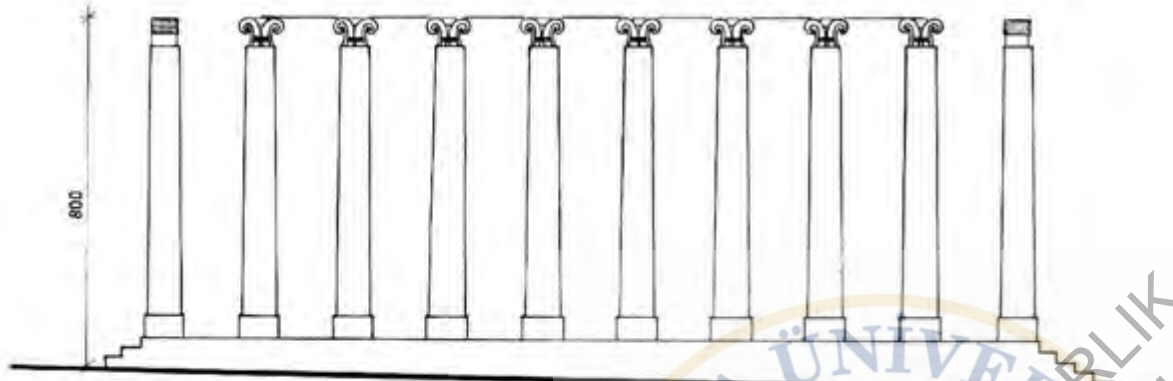

GÖRÜNÜŞ Ö:1/100

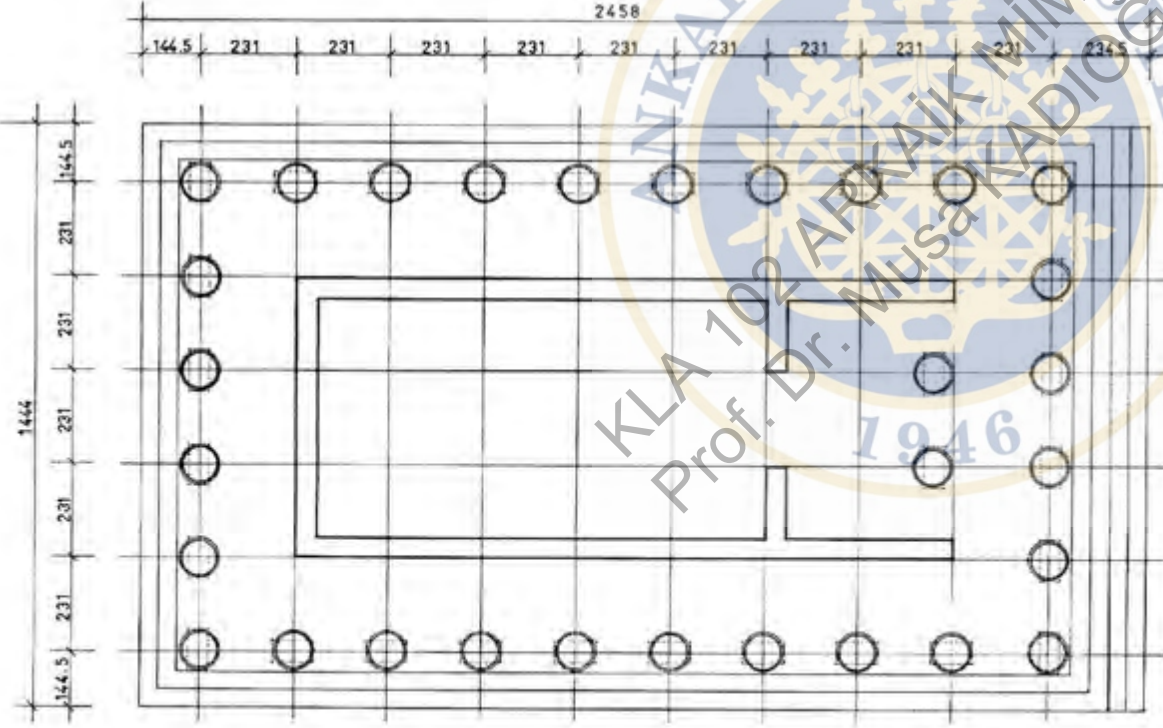

PLAN Ö:1/100

Res. 16
Smyrna, Erken Arkaik
Dönem Tapınağı
II. Evre, 6x10 peripteros.

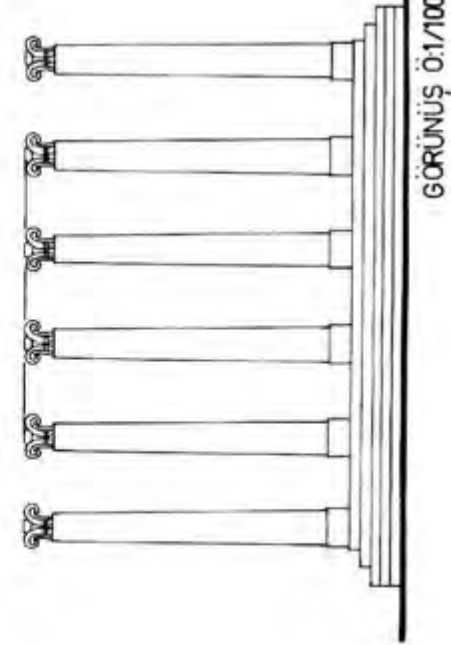

GÖRÜNÜŞ Ö:1/100

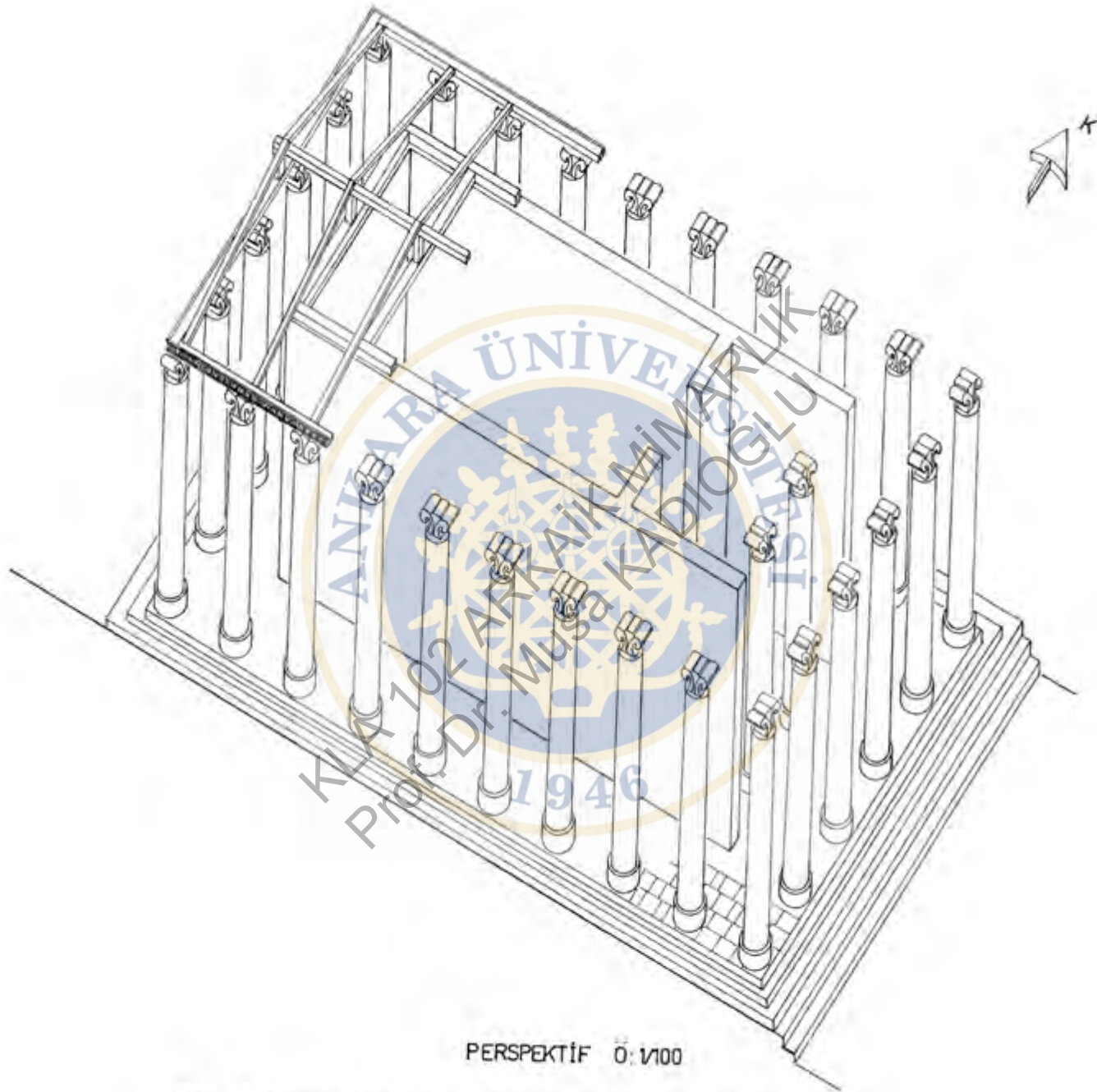

Res. 17 Smyrna, Erken Arkaik Dönem Tapınağı, II. Evre. Öneri çizimi.

Lesbos Adası, Klopedi Tapınağı (MÖ 6. yy 2. yarısı)



Fig.IV.121. Klopedi Tapınağı'nın günümüzdeki durumu

NEANDRIA

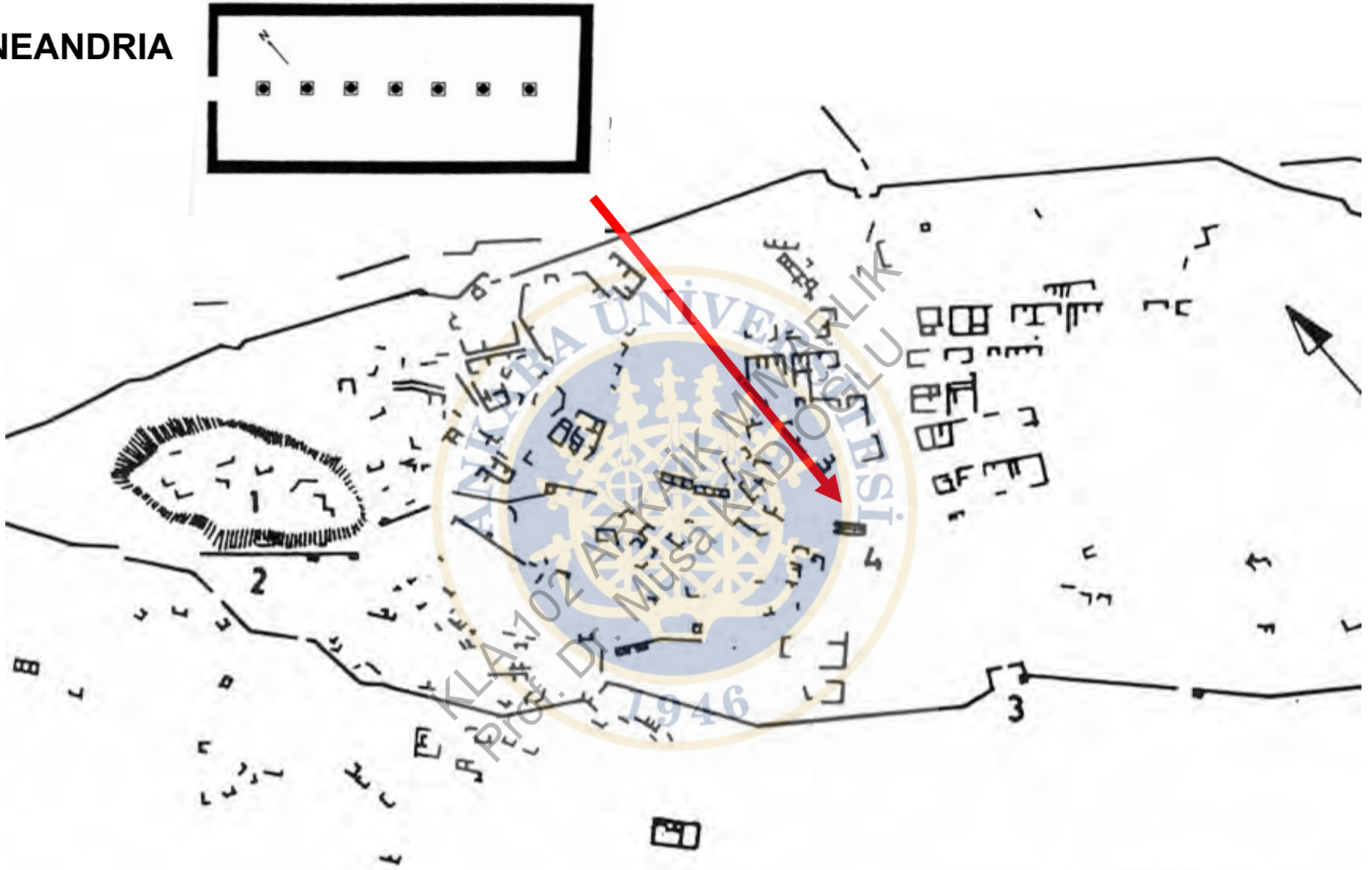

Şek. 278 - Neandria'nın planı. 1) Arkaik akropol. 2) Eski surlar (olasılıkla M.Ö. 6. yüzyıl). 3) Kent suru ile birlikte M.Ö. geç 5. yüzyıla tarihlenen ana giriş. 4) Arkaik tapınak, yaklaşık M.Ö. 600.

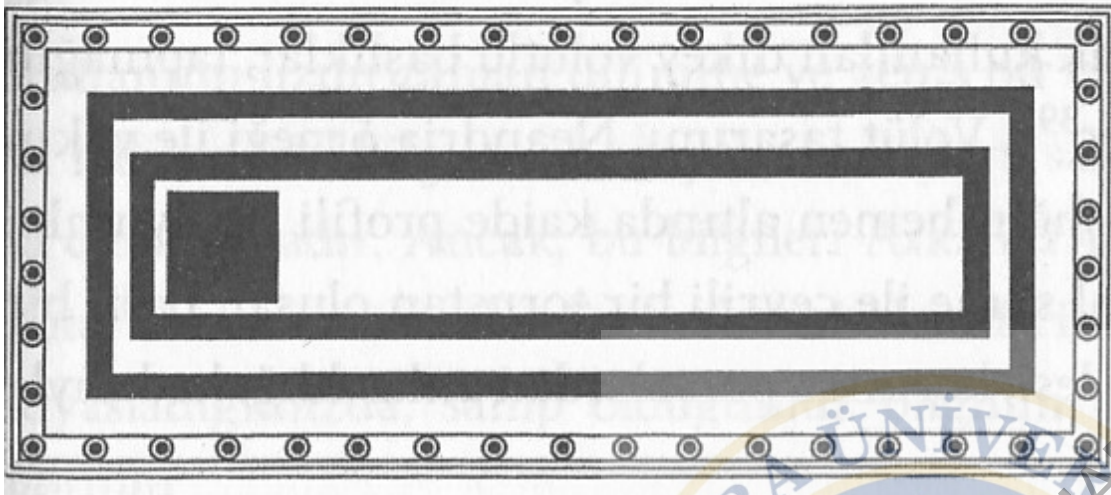

Fig.IV.120. Klopedi Tapınağı, plan
(Betancourt 1977: Fig. 40)

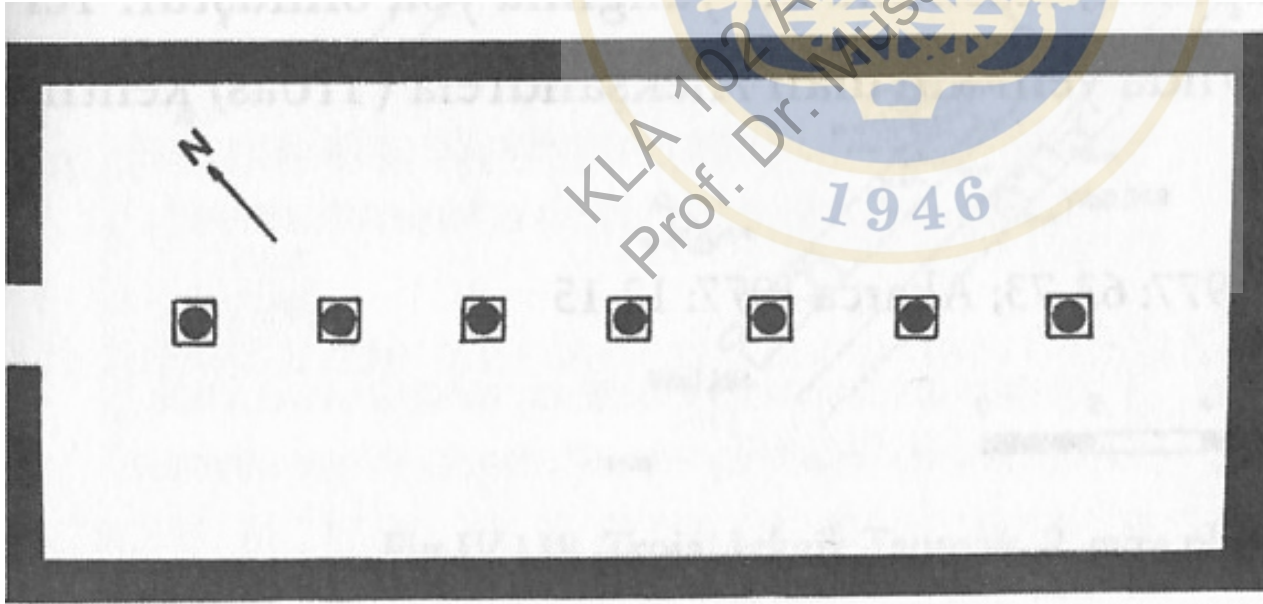

Fig.IV.117.
Neandria Tapınağı planı
(Betancourt 1977: Fig. 31)

ANKARA ÜNİVERSİTESİ
1946
KLA 102 ARKAİK MİMARLIK
Prof. Dr. Musa KADIOĞLU

LARISA



Smyrna Athena Tapınağı, Erken Arkaik Dönem II. Evre

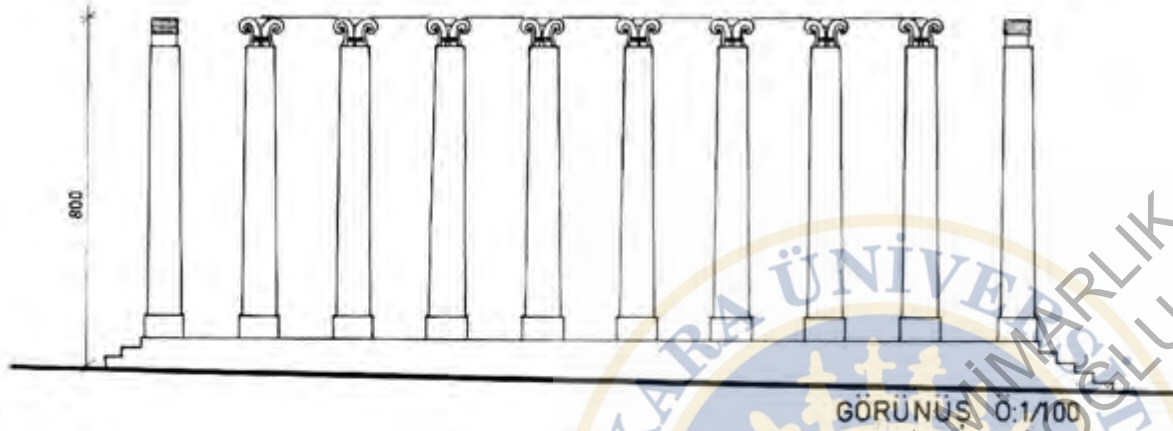

Res. 16
Smyrna, Erken Arkaik
Dönem Tapınağı
II. Evre, 6x10 peripteros.

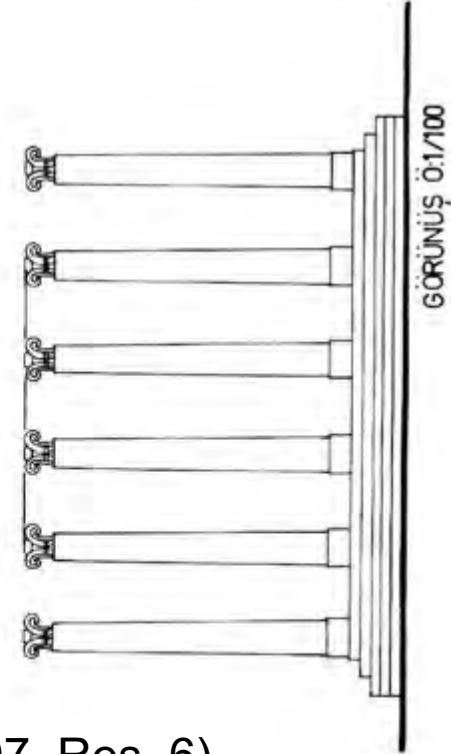
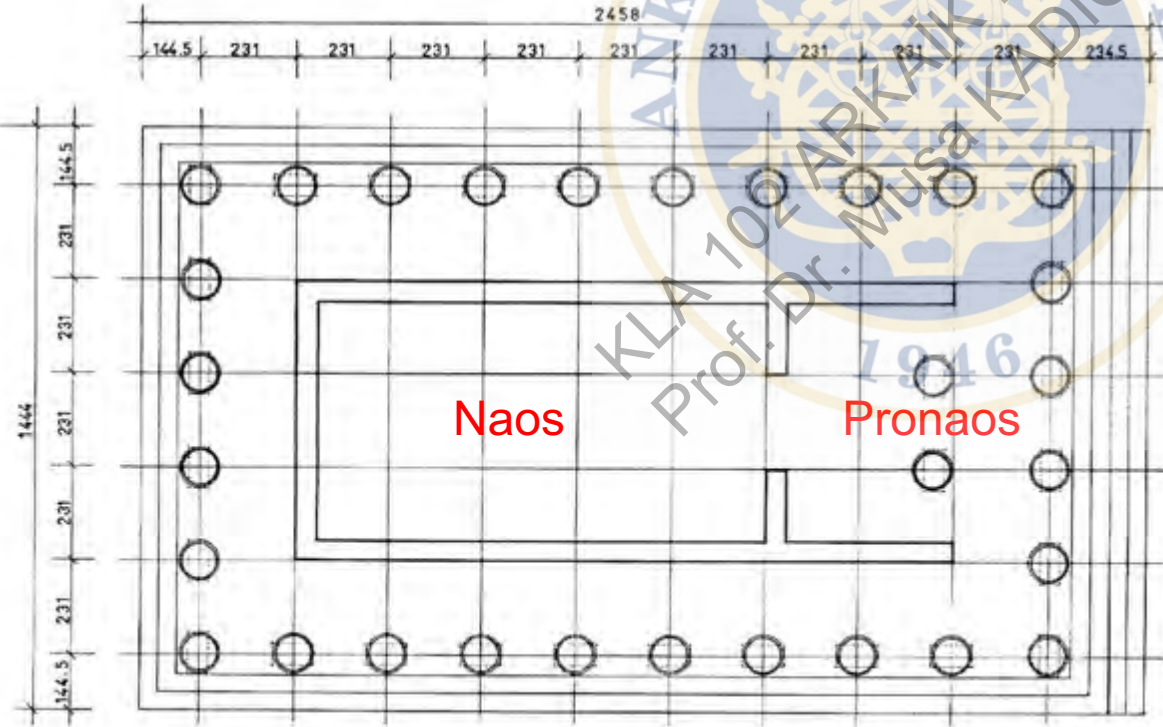

(Akurgal 2007, Res. 6)

Lesbos Adası, Klopedi Tapınağı (MÖ 6. yy 2. yarısı)



Fig.IV.121. Klopedi Tapınağı'nın günümüzdeki durumu

LARİSA, Eski Saray

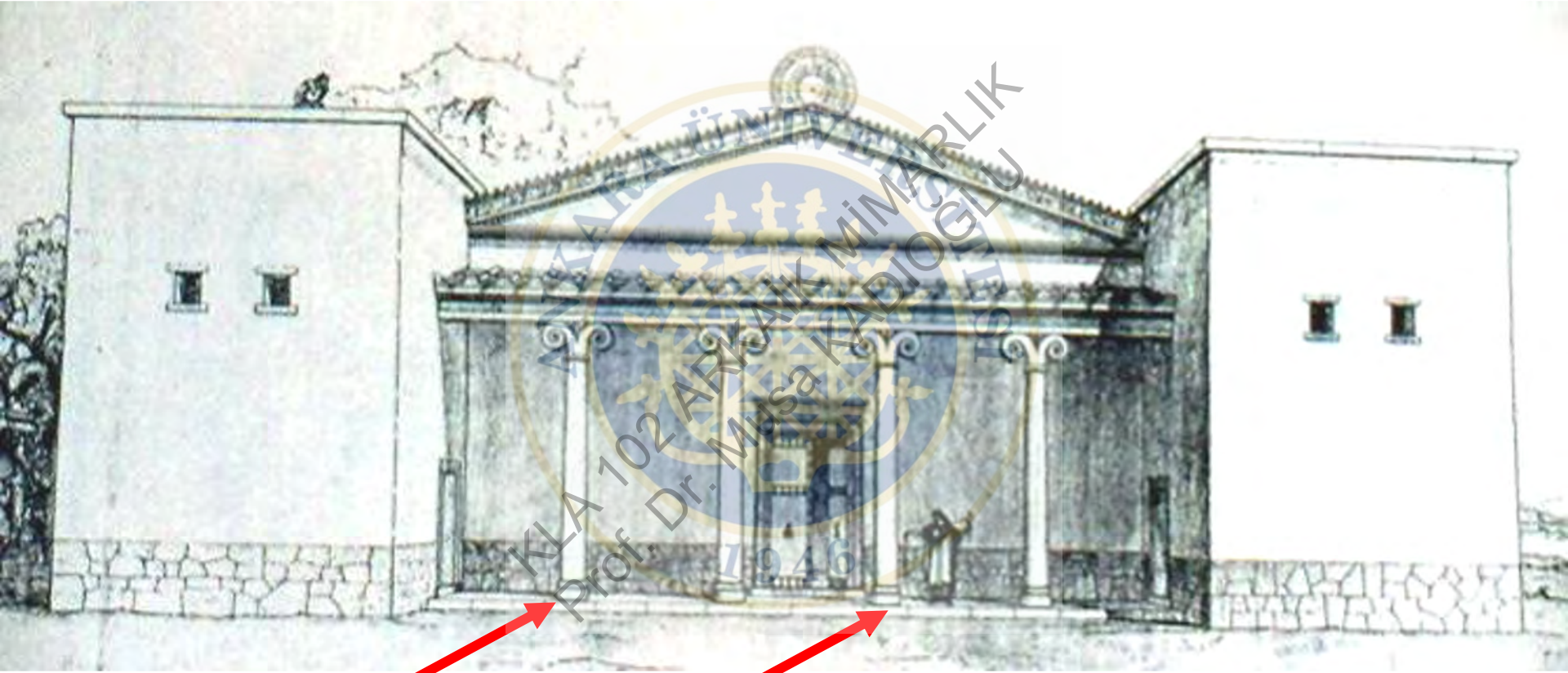

Lesbos Adası, Klopedi Tapınağı (MÖ 6. yy 2. yarısı)

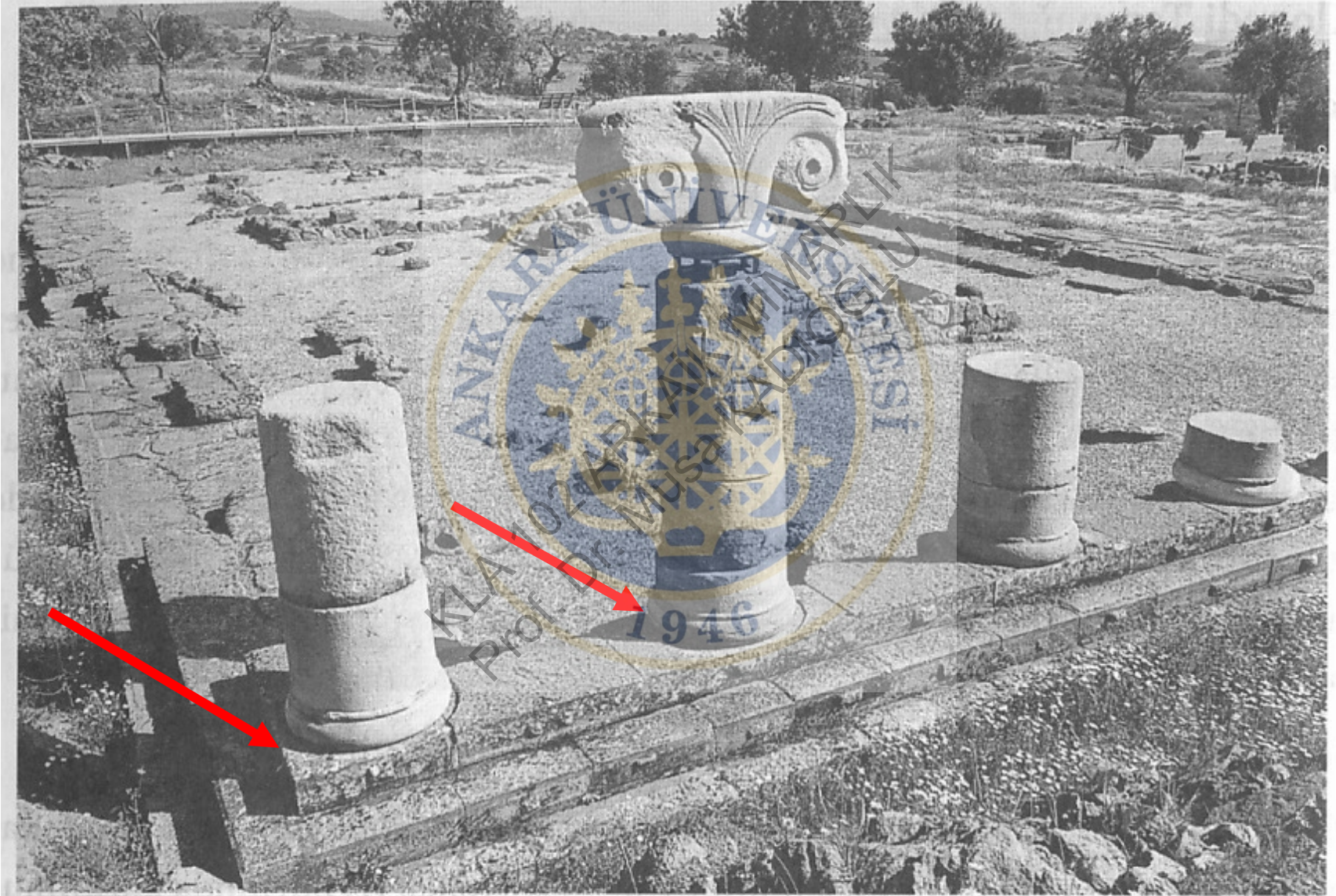

Fig.IV.121. Klopedi Tapınağı'nın günümüzdeki durumu



Abb. 43 Alt-Smyrna. Athenatempel.
Kapitell A. Tuffstein. Um 600 v. Chr.
(Aufnahme und Zeichnung: Meral Manyas)



Abb. 44 Alt-Smyrna. Athenatempel.
Kapitell B. Tuffstein. Um 600 v. Chr. Aus
Dutzenden Fragmenten zusammengesetzt
von Orhan Bingöl (Aufnahme und Zeich-
nung: Meral Manyas)

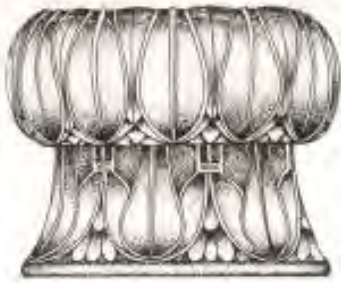

Abb. 45 Alt-Smyrna. Athenatempel.
Kapitell C. Tuffstein. Um 600 v. Chr. Aus
Dutzenden Fragmenten zusammengesetzt
von Meral Manyas (Aufnahme und
Zeichnung: Meral Manyas)



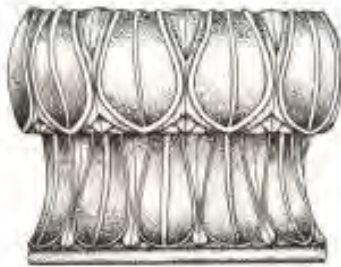

ANKARA ÜNİVERSİTESİ
MİMARLIK
RADIOĞLU
1946
ZILA 102 ARKAIT
Prof. Dr. Musa

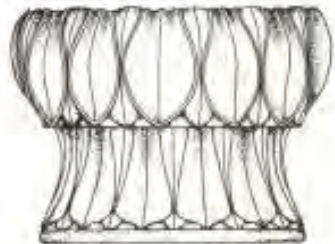
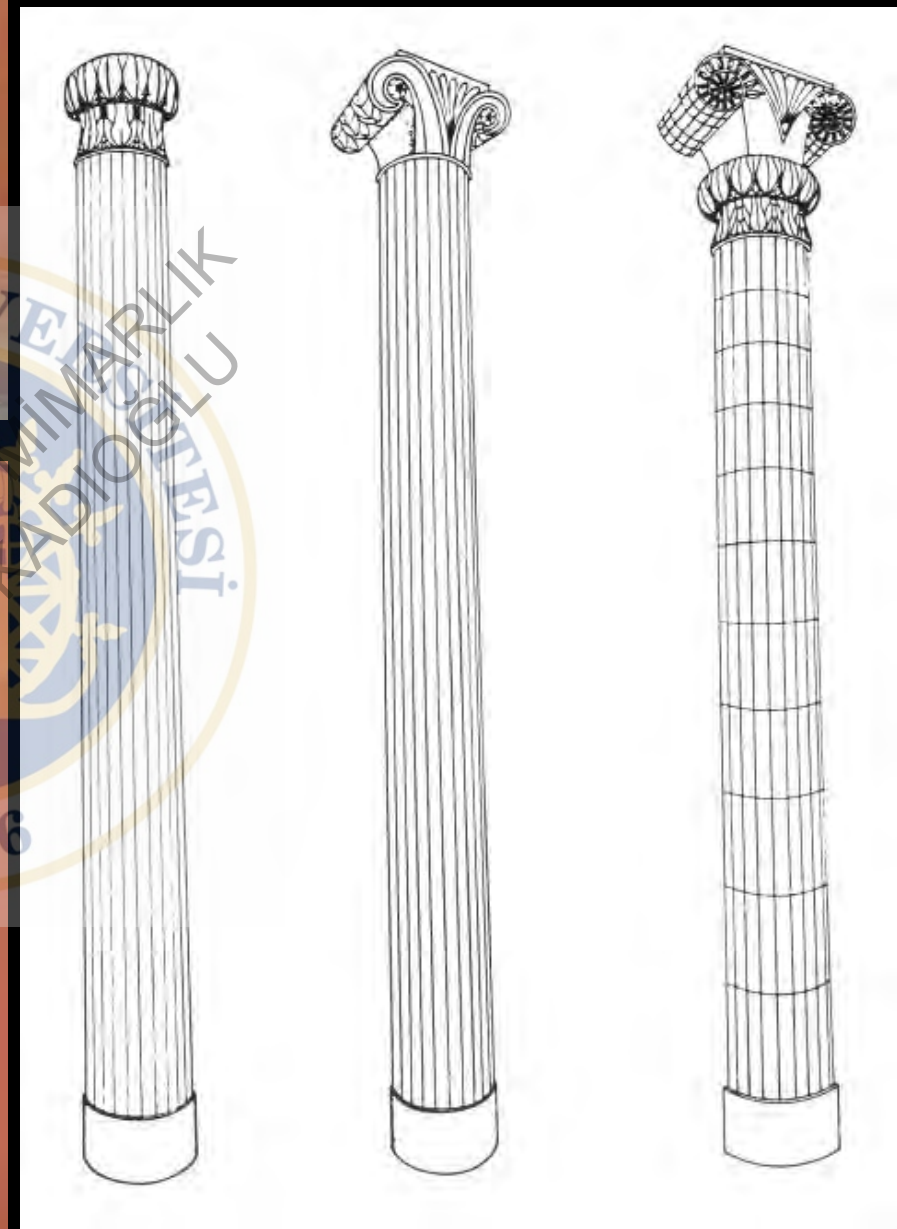
Smyrna Athena Tapınađı Mantar Bařlık



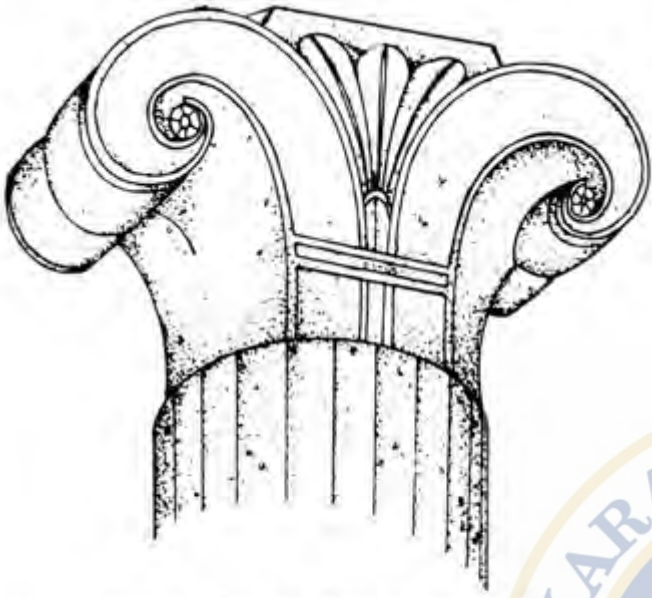

Res. 7 Smyrna Athena Tapınağı.
Dikey volütlü başlık, tüftaşı.
MÖ 7. yüzyıl son dörtlük.

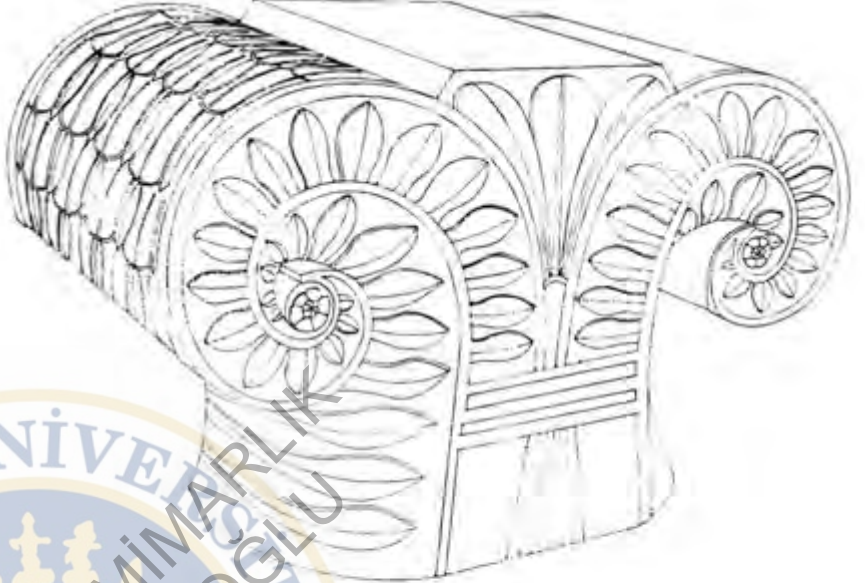

Res. 8 Smyrna Athena Tapınağı.
Dikey volütlü başlık, tüftaşı.
MÖ 7. yüzyıl son dörtlük.

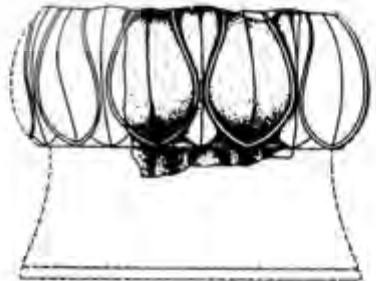
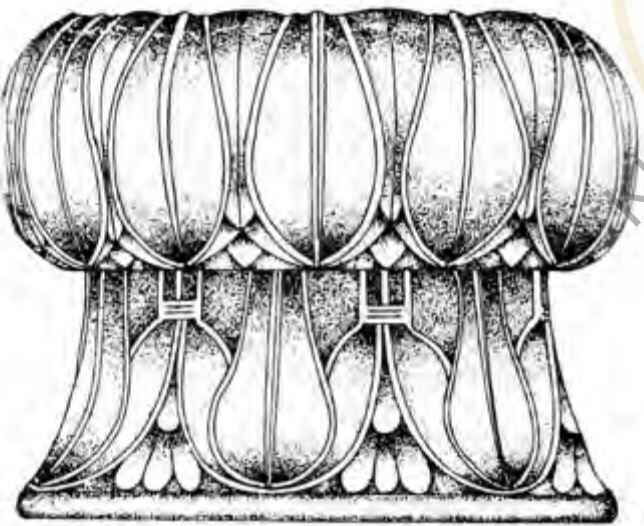

Res. 11-13 Smyrna Athena Tapınağı. Mantar biçimli A-C başlıkları.
MÖ 7. yüzyıl sonu.





Abb. 163, b. Alt-Smyrna. Athenatempel.
Volutenkapitell o. Rekonstruktionsvor-
schlag des Verfassers (Zeichnung: Murat
Erdim)



Bayraklı Athena Tapınağı, Aiol
başlıklar, MÖ 600

SMYRNA ATHENA TAPINAĐI

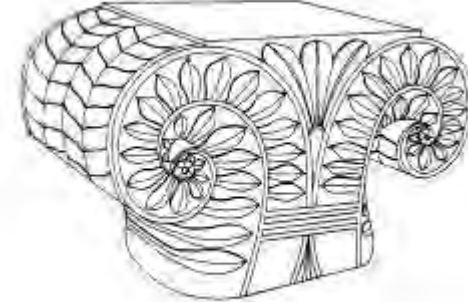
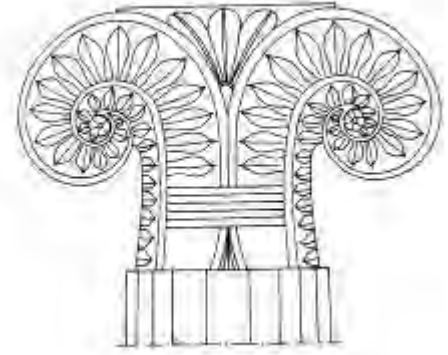

AİOL MİMARİSİ

Aiol Başlığı, Eski Yunan boylarından olan ve MÖ 12. yüzyılda Dor Göçleriyle birlikte Kuzeybatı Anadolu'ya göçen ve orada yerleşen Aiol'lerden ve Aiolia Bölgesi'nden ismini alır. **İon başlığının en eski biçimi olarak** karşımıza çıkar. Başlık **altta sütun boynunu süsleyen asılı bir yaprak** sırası ve üst kısmında dışarı ve aşağı doğru kıvrım yapan birer volütten oluşturulmuştur. Her iki volüt arasında ise bir palmet yer alır.

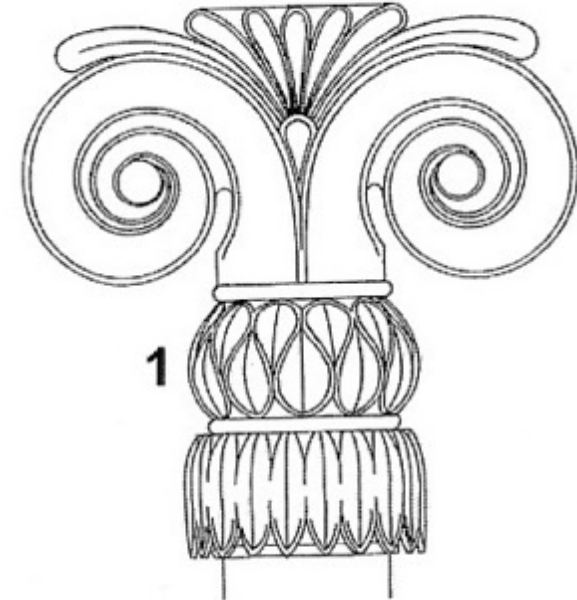

Neandria Athena
Tapınağı Aiol sütün
başlığı

Samos Heraion' u İon Başlığı

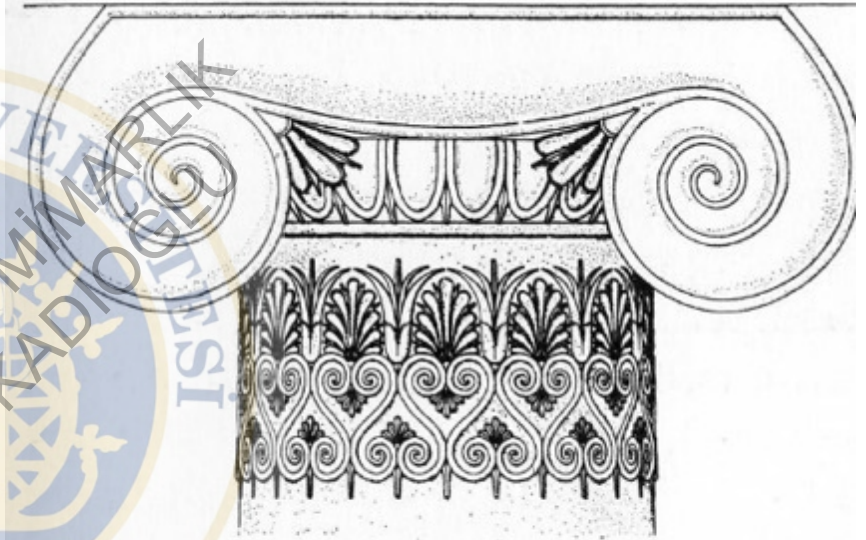
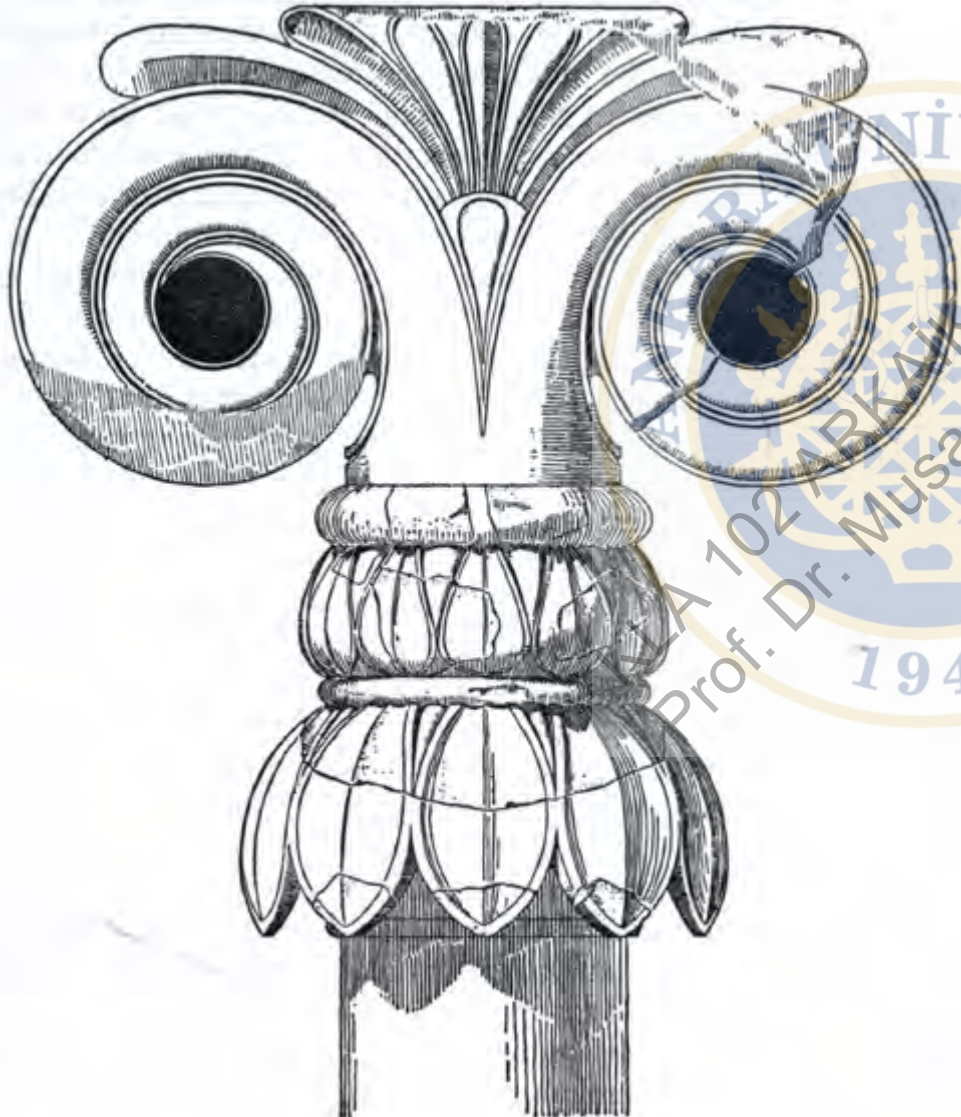

271 Kapitell mit Säulenhals-Anthemion vom p
Samos, um 480 v. Chr., Vorder- und Seitenansich



Figür-70



Figür-71

MKA 102 ARKAIK MUSEUM
Prof. Dr. Musa KADIOĞLU
1946

Neandria, Aeol başlık, MÖ 600-575



Pl. 41. Neandria. Capital from the Archaic temple as restored by R. Koldewey, with three superimposed elements. About 575-550 B.C. By courtesy of the Archaeological Museum, Istanbul, no. 085.

Neandria, Aeol başlık, MÖ 600-575

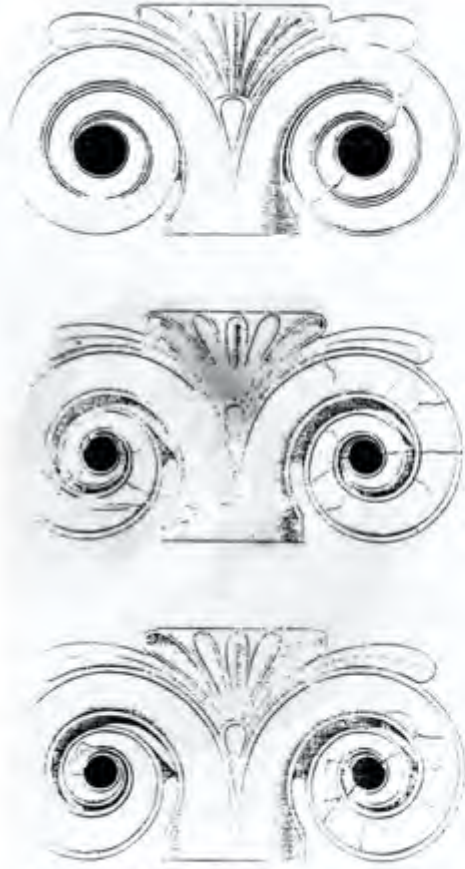

Fig. 25. Volute elements from the temple at Neandria. After Koldewey, *Neandria*, figs. 60-62.



Fig. 26. Smaller volute element from the temple at Neandria. After Koldewey, *Neandria*, fig. 63.



Fig. 27. The smaller leaf drums from the temple at Neandria. After Koldewey, *Neandria*, figs. 60-62.



Fig. 28. The larger leaf drums from Neandria, shown upon shafts as capitals. After Koldewey, *Neandria*, figs. 60-62.

Neandria, Aeol başlık, MÖ 600-575

Lesbos Adası, Klopedi Aeol Başlık

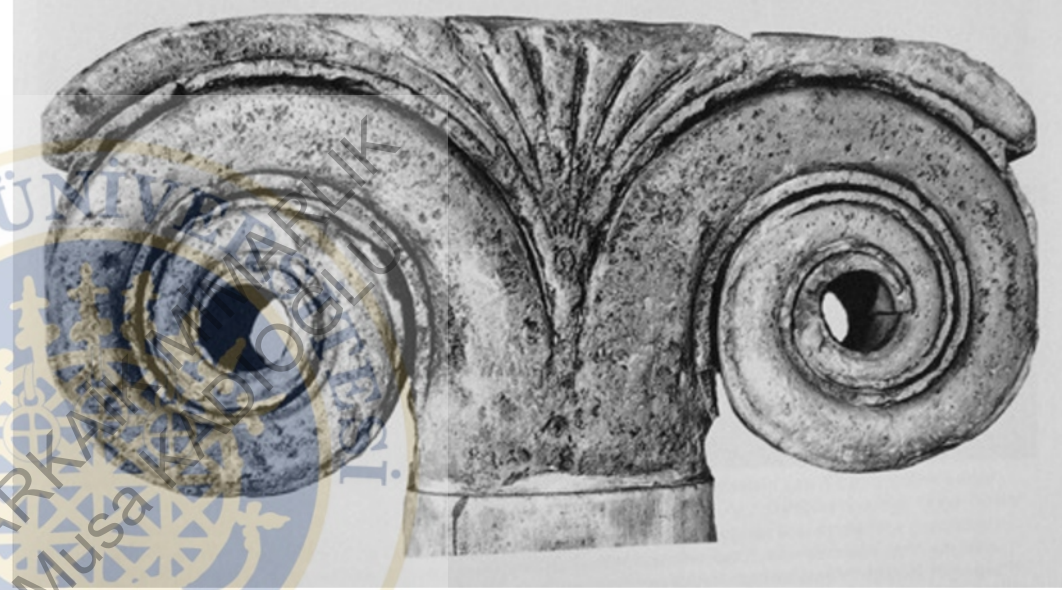

Pl. 41. Neandria. Capital from the Archaic temple as restored by R. Koldewey, with three superimposed elements. About 575-550 B.C. By courtesy of the Archaeological Museum, Istanbul, no. 985.

LESBOS

KLOPEDI, Tapınak Geç 6. yüzyıl



Pl. 49. Klopei. Aeolic capital from the temple. Late sixth century a.c. or slightly later. By courtesy of the Italian School of Archaeology in Athens. After J. D. Condis, "Capitello eolico di Eresso," *ASAA*, new series, 8-10 (1946-1948) fig. 3.

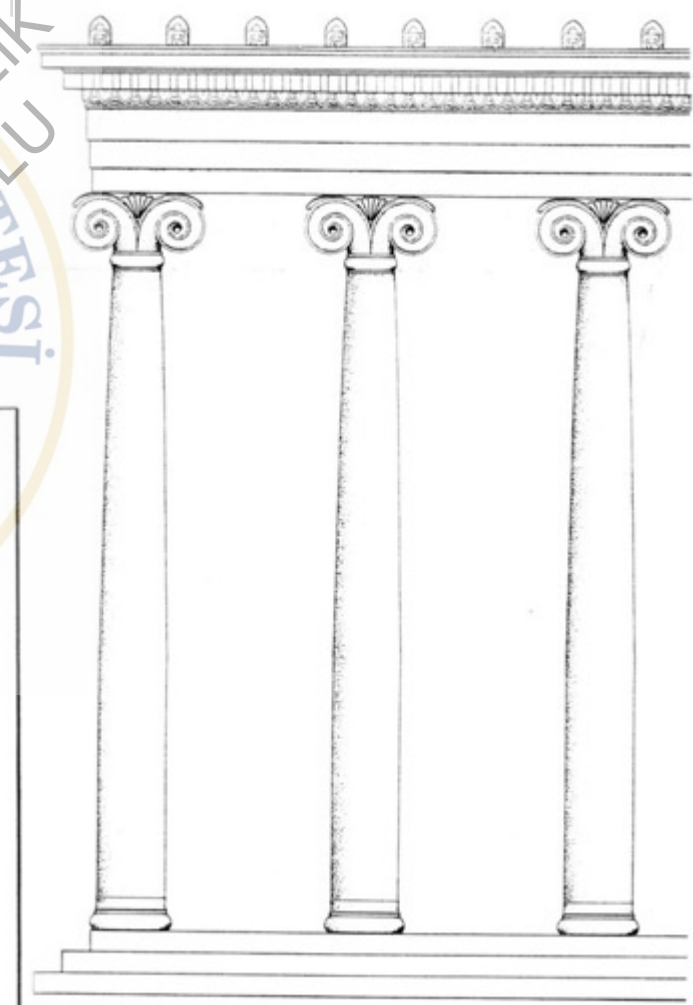

Fig. 42. Elevation of the Aeolic temple at Klopei.

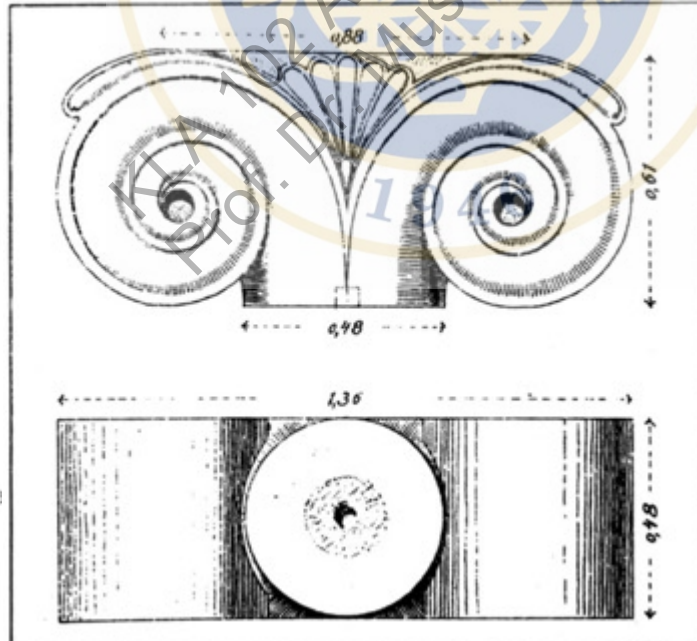
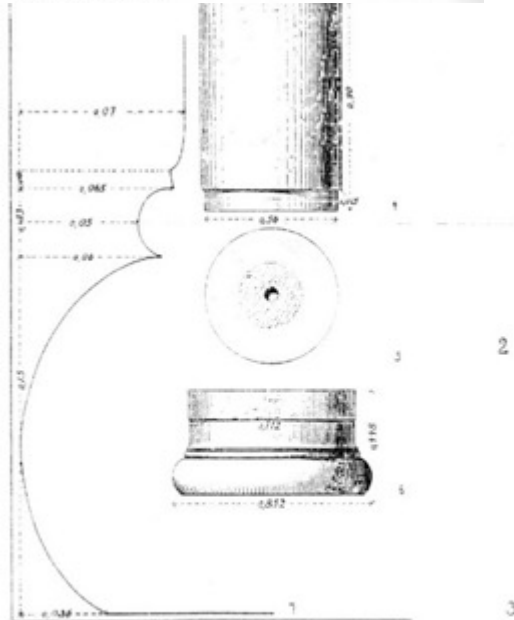

Fig. 41. Elements from the larger temple at Klopei.

No. 1. Column base and drum, nos. 2-3, Aeolic capital. After Koldewey, *Die antiken Baureste der Insel Lesbos* (1890) pl. 16 nos. 2-7.



Smyrna



İsrail, Ramat Rahel



Abb. 46a, b Alt-Smyrna. Athenatempel. Volutenkapitell p. Rekonstruktionsvorschlag des Verfassers (Zeichnung: Murat Erdim)





Res. 7 Smyrna Athena Tapınağı.
Dikey volütlü başlık, tüftaşı.
MÖ 7. yüzyıl son dörtlük.

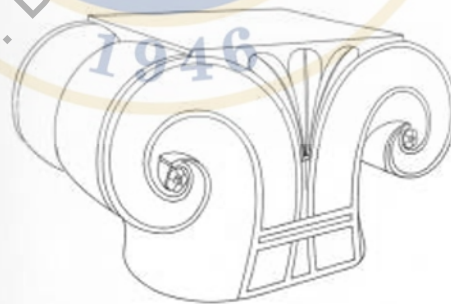
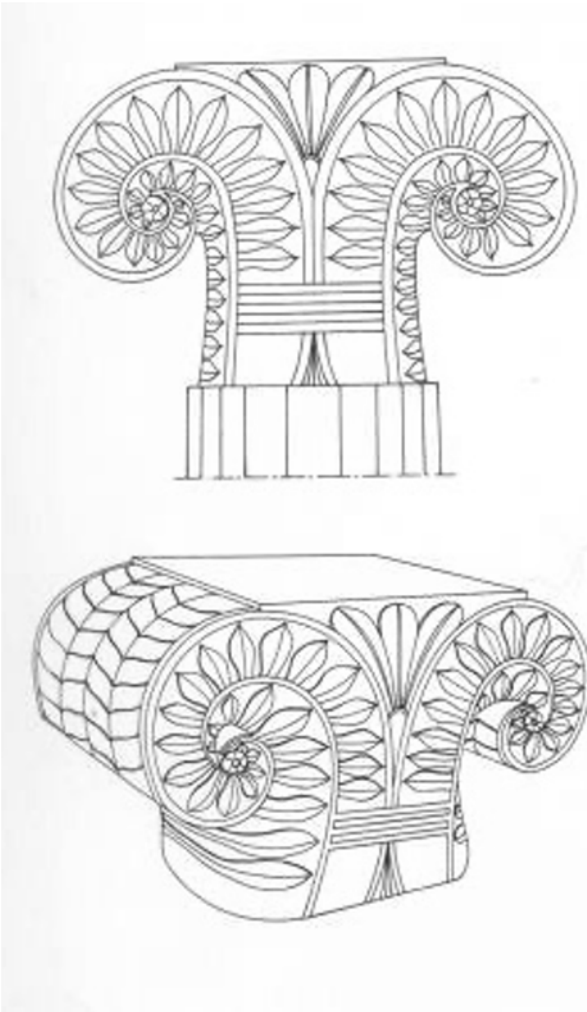
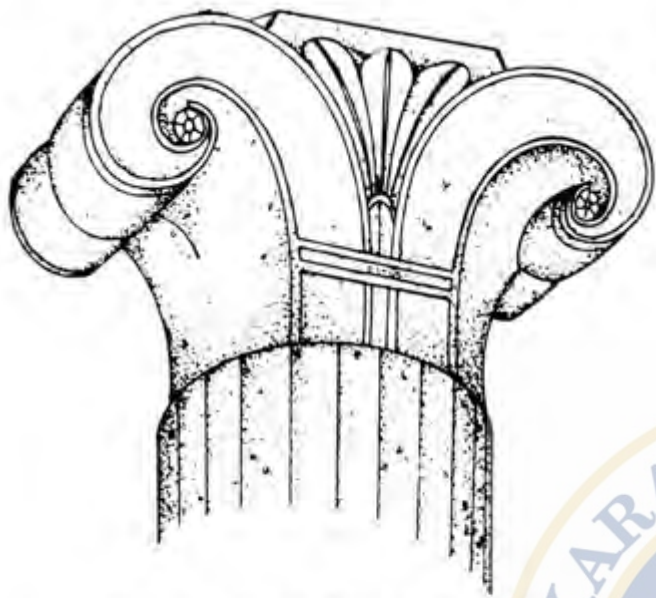
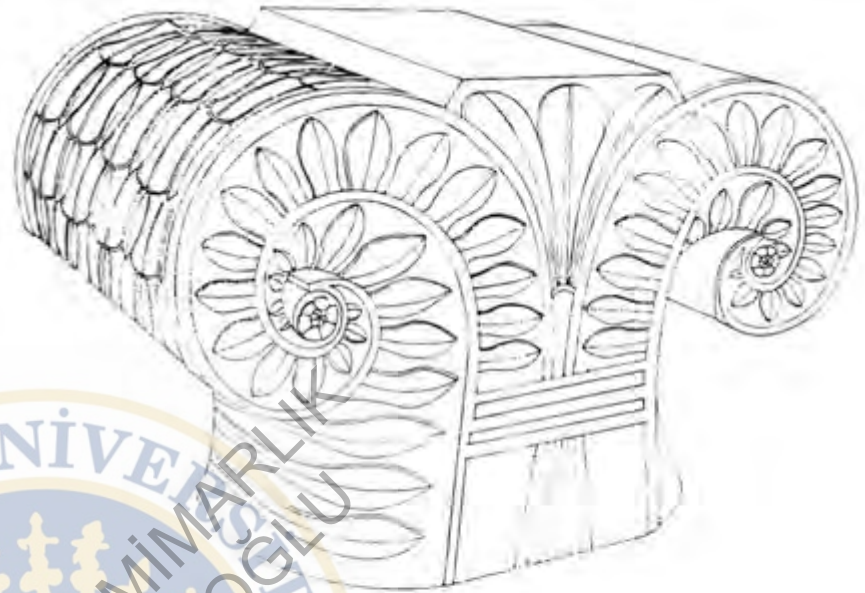

Res. 8 Smyrna Athena Tapınağı.
Dikey volütlü başlık, tüftaşı.
MÖ 7. yüzyıl son dörtlük.

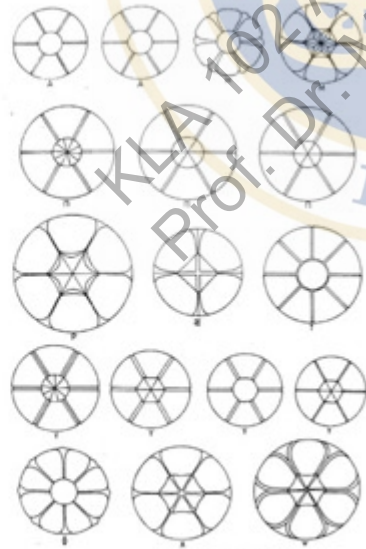

Res. 10 Smyrna Athena Tapınağı.
Dikey volütlü başlık rozetleri.





14 a - Aiol sütun başlıkları. Piççe taş (Tuf). Her iki yönde malzeme çitiliktir. Solundakiler, 7. yüzyılın başlarında; sağdakiler 470. İsmail Arslan'ın Müzesi.

Smyrna Aeol Başlıkları, MÖ 570



Pl. 45. Larisa. Reconstruction of the Old Palace, showing the front facade. About 550 B.C. By courtesy of Walter de Gruyter and Co., Berlin. After Bochlau and Schefold. *Larisa* 1, pl. 30.

LARISA, Eski Saray





LARİSA

Larisa, Aeol Başlık (MÖ 550-525)

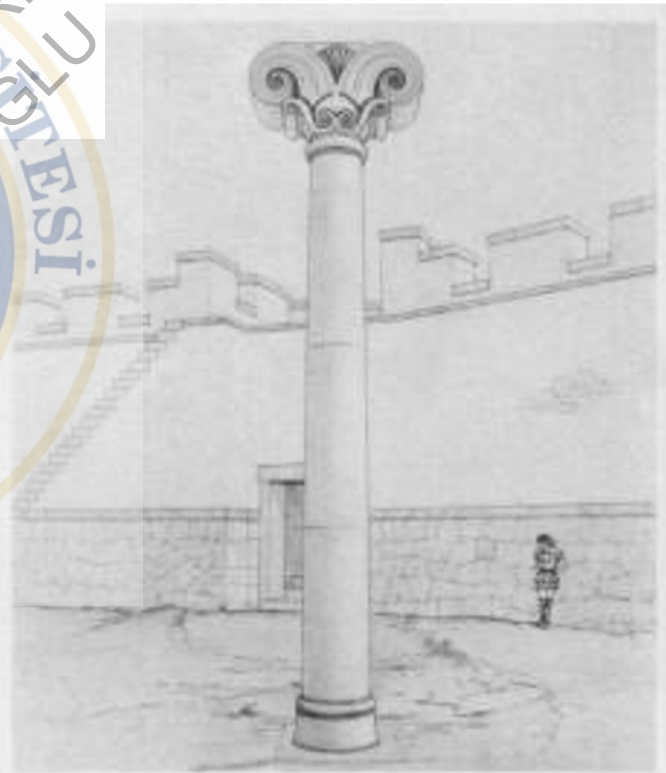

Pl. 44. Larisa. Reconstruction of the large stone capital as the crowning member of an isolated column. By courtesy of Walter de Gruyter and Co., Berlin. After Bochlau and Schefold, *Larisa* 1, pl. 29.



Pl. 47. Larisa. Fragment of the left volute of an Aeolic capital, assigned to the Old Palace. About 550 B.C. By courtesy of the Archaeological Museum, Istanbul, no. 1926.

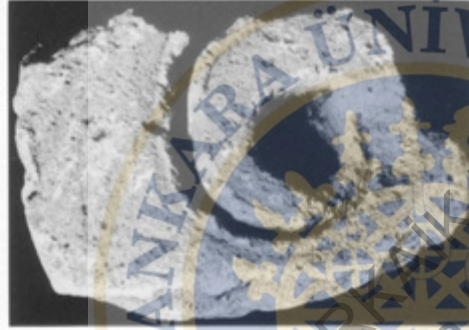

Pl. 48. Larisa. Fragment of a small Aeolic capital, probably from a votive column. Last third of the sixth century B.C. By courtesy of the Archaeological Museum, Istanbul, no. 1926.

Larisa, Aeol başlıklar, MÖ 550-525



ANKARA ÜNİVERSİTESİ
MİMARLIK
KLA 101
Prof. Dr. Musa RADOĞLU
1946

LESBOS, MYTILENE



ENEZ (AINOS)

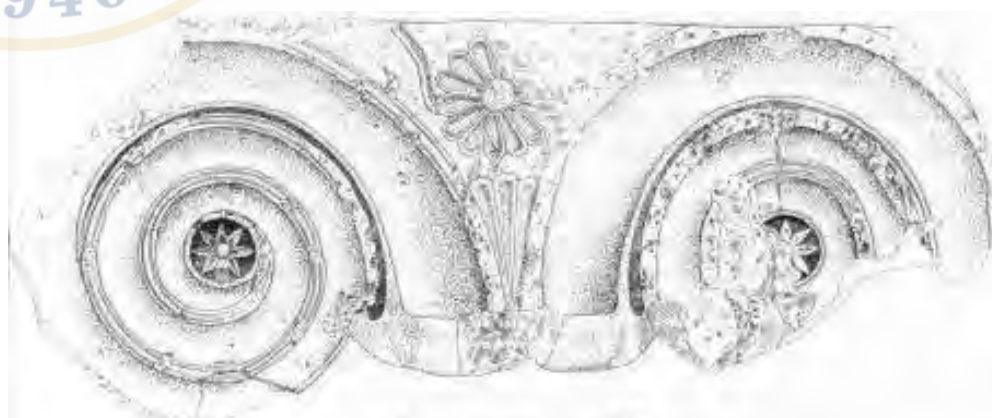
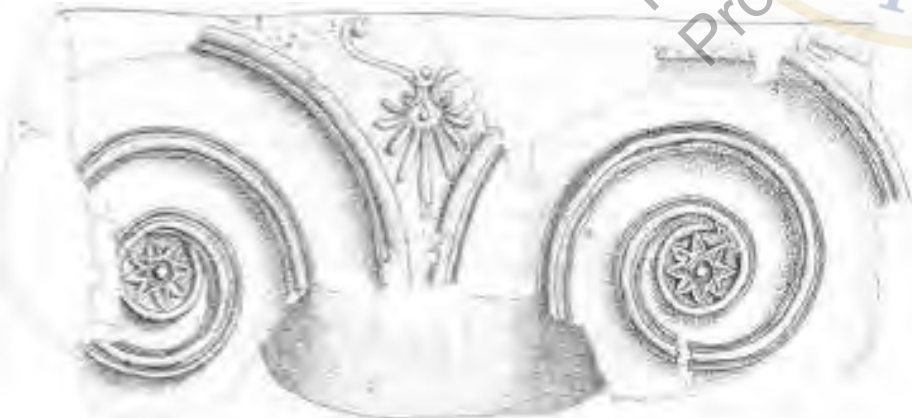

ANKARA ÜNİVERSİTESİ
KLA 102 ARKAITİK MİMARLIK
Prof. Dr. Musa KADIOĞLU
1946

Bodrum Yarımadası, Alazeytin, 30 Numaralı Yapı (Tapınak ?), MÖ 550-525

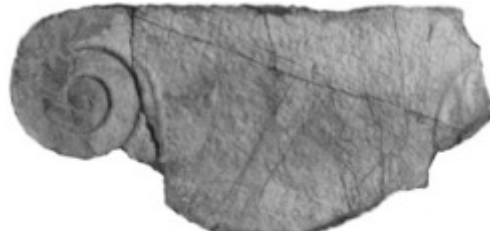
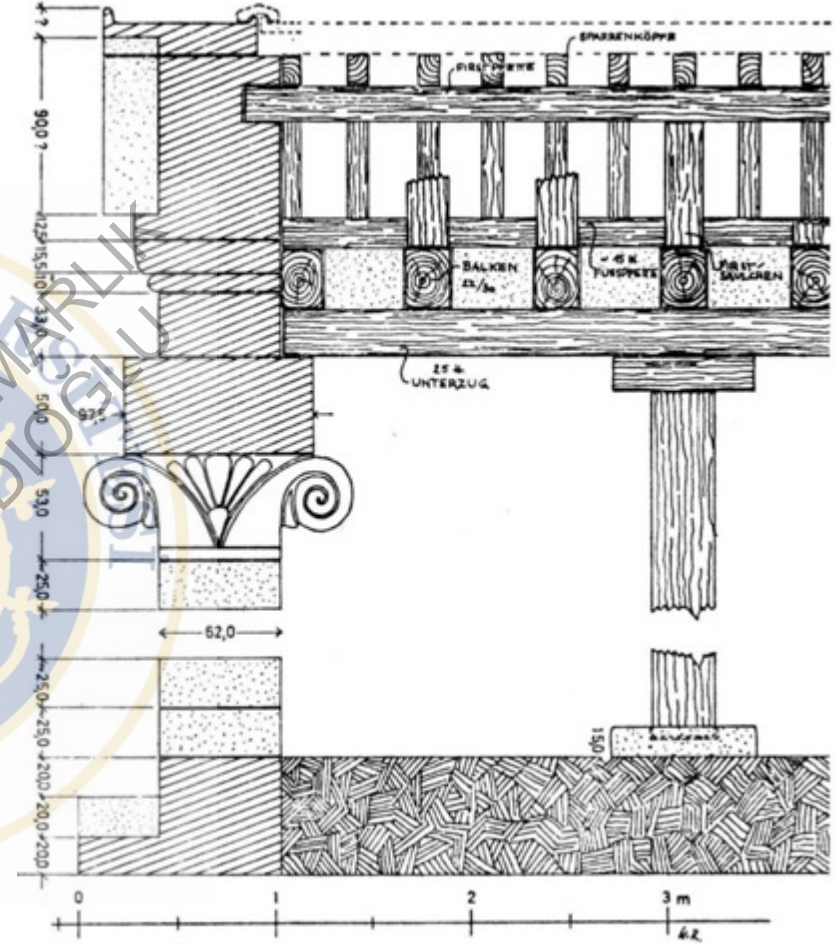
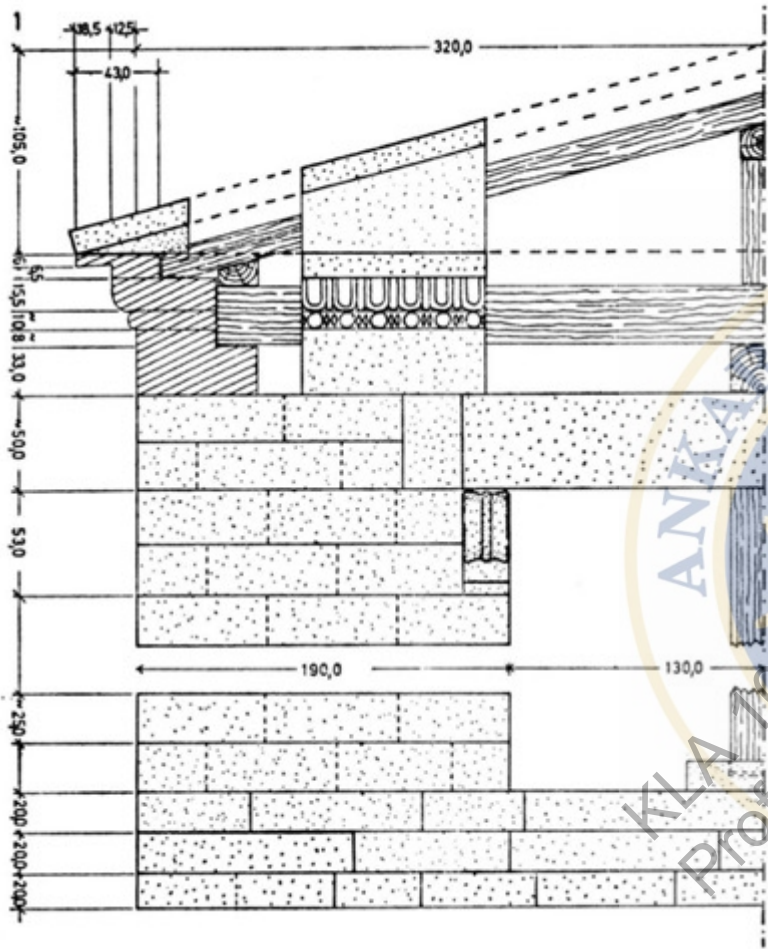



1: AB.1, Alazeytin, ön cephe



1: AB.2, Alazeytin, ön cephe

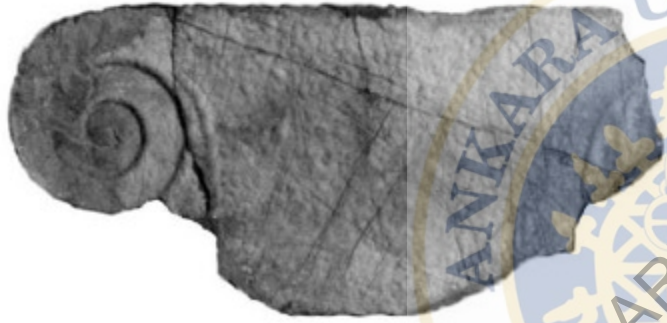

2: AB.1, Alazeytin, arka cephe



2: AB.2, Alazeytin, arka cephe



3: AB.1, Alazeytin, üst cephe



4: AB.1, Alazeytin, arka cephe volüt parçası



3: AB.2, Alazeytin, üst yüzey

Alazeytin, 30 Numaralı Yapı (Tapınak ?), MÖ 550-525

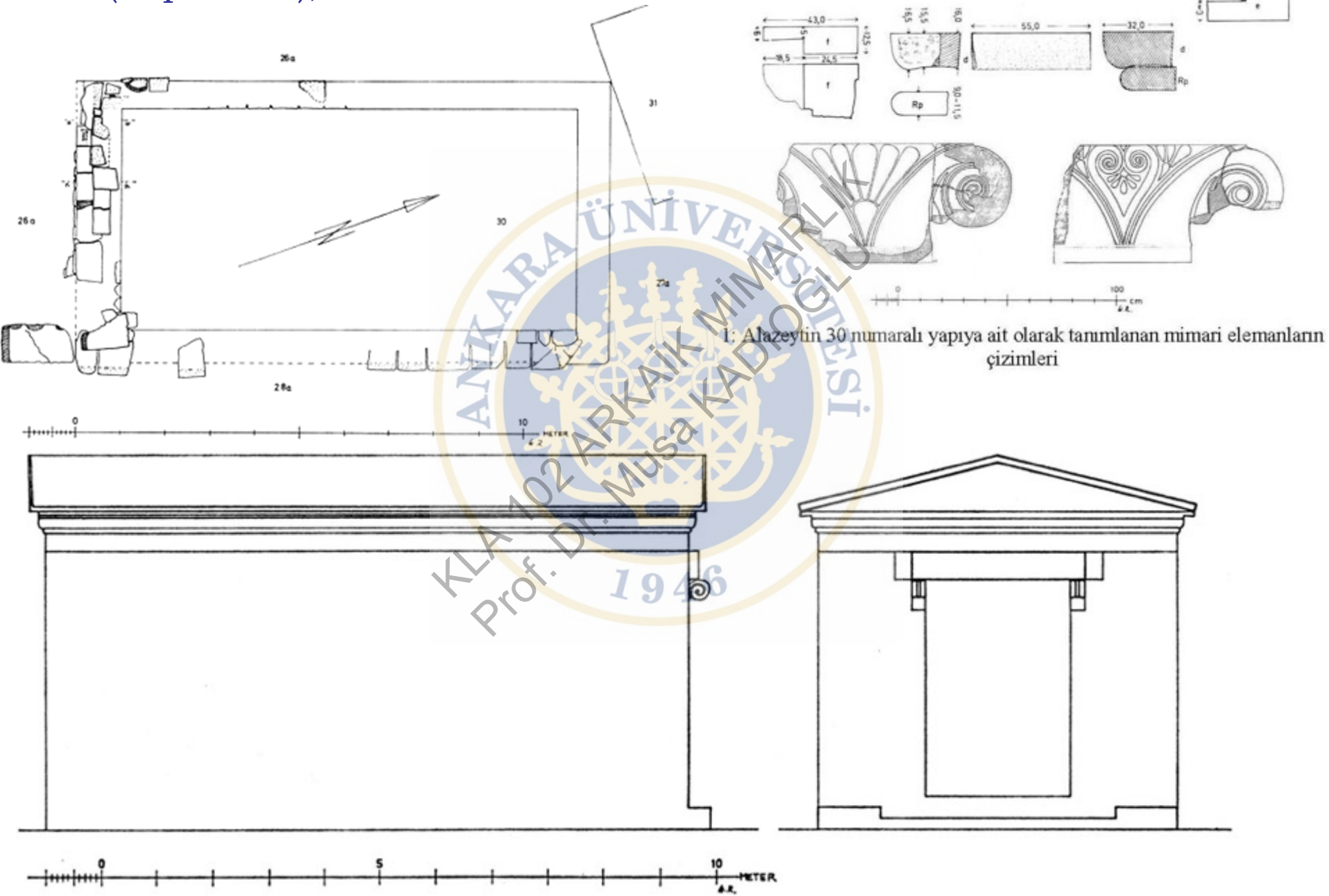

Şekil 1: Alazeytin 30 numaralı yapıya ait olarak tanımlanan mimari elemanların çizimleri

**Alazeytin, 31
Numaralı Yapı
(Altar ?), MÖ
550-525**



1: Alazeytin 31 numaralı yapı, mevcut kalıntılar

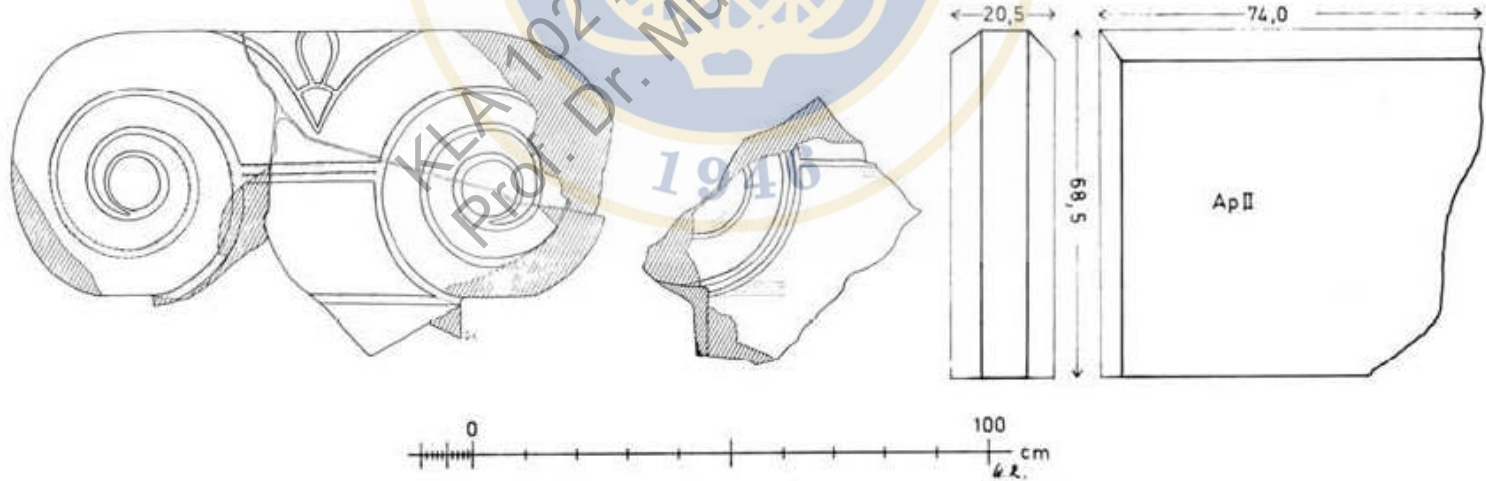

6: Alazeytin 31 numaralı yapıya ait olarak tanımlanan mimari elemanların çizimleri

Alazeytin, 31 Numaralı Yapı (Altar ?),
MÖ 550-525

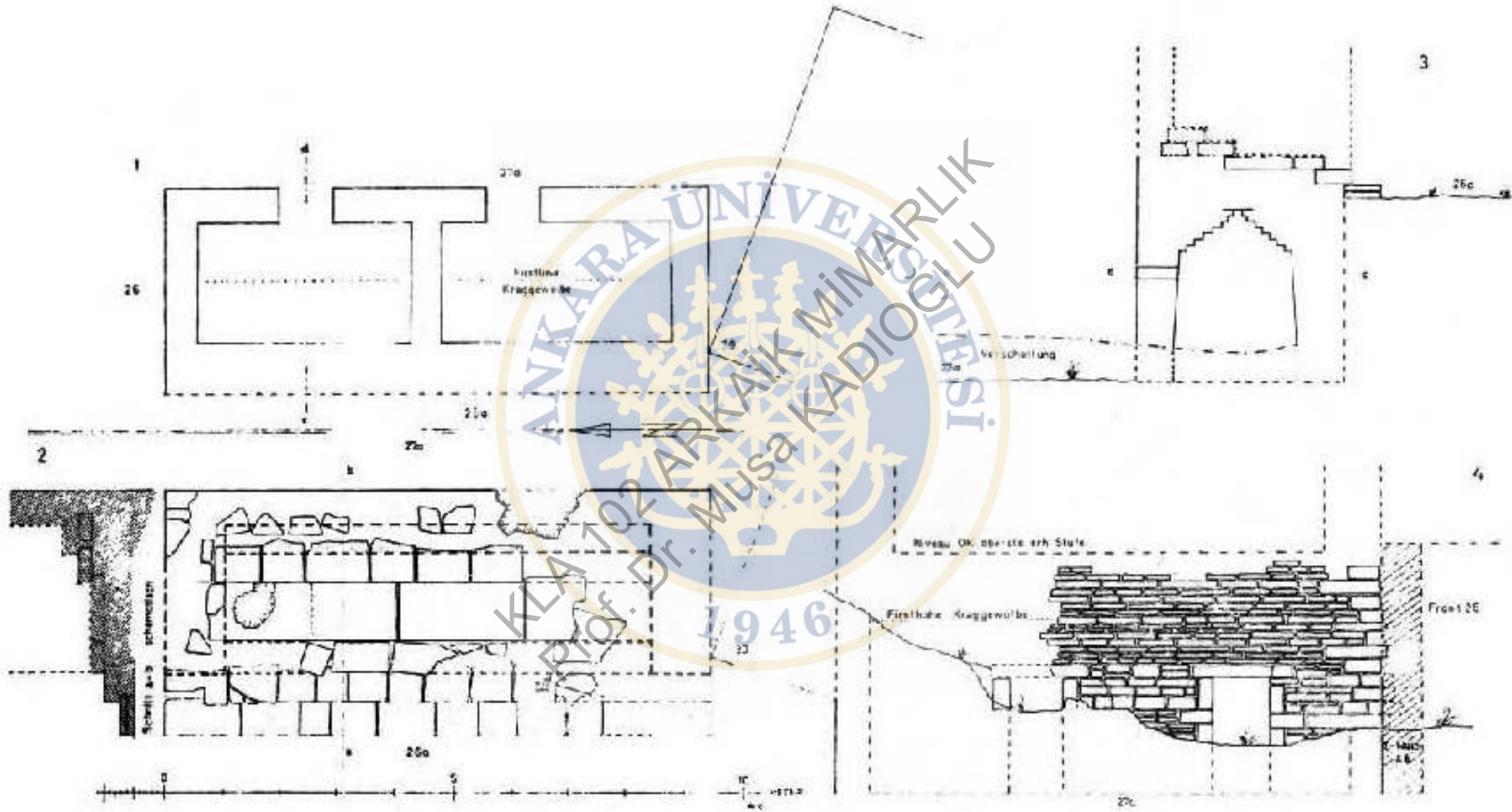

2-5: Alazeytin 31 numaralı yapı, plan ve kesitler

Alazeytin
Syangela

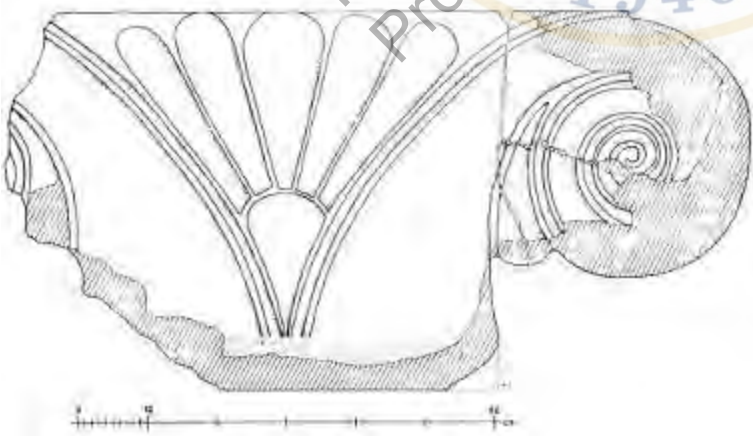
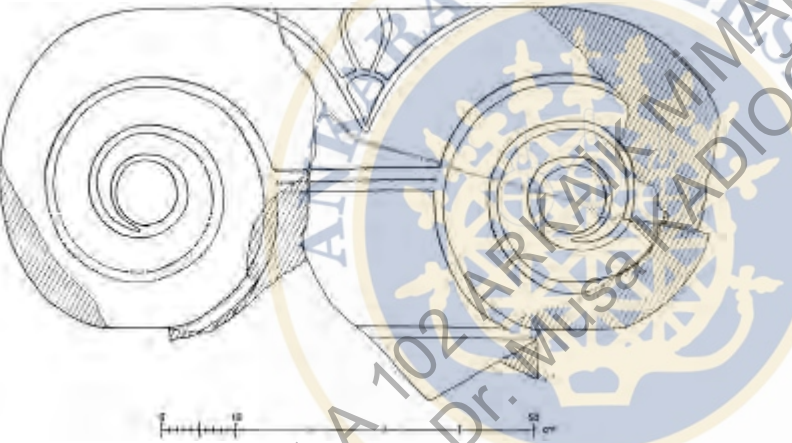

KLA 102 ARK.
Prof. Dr. Musa YADIOĞLU
ALAZEYİN ÜNİVERSİTESİ
1946

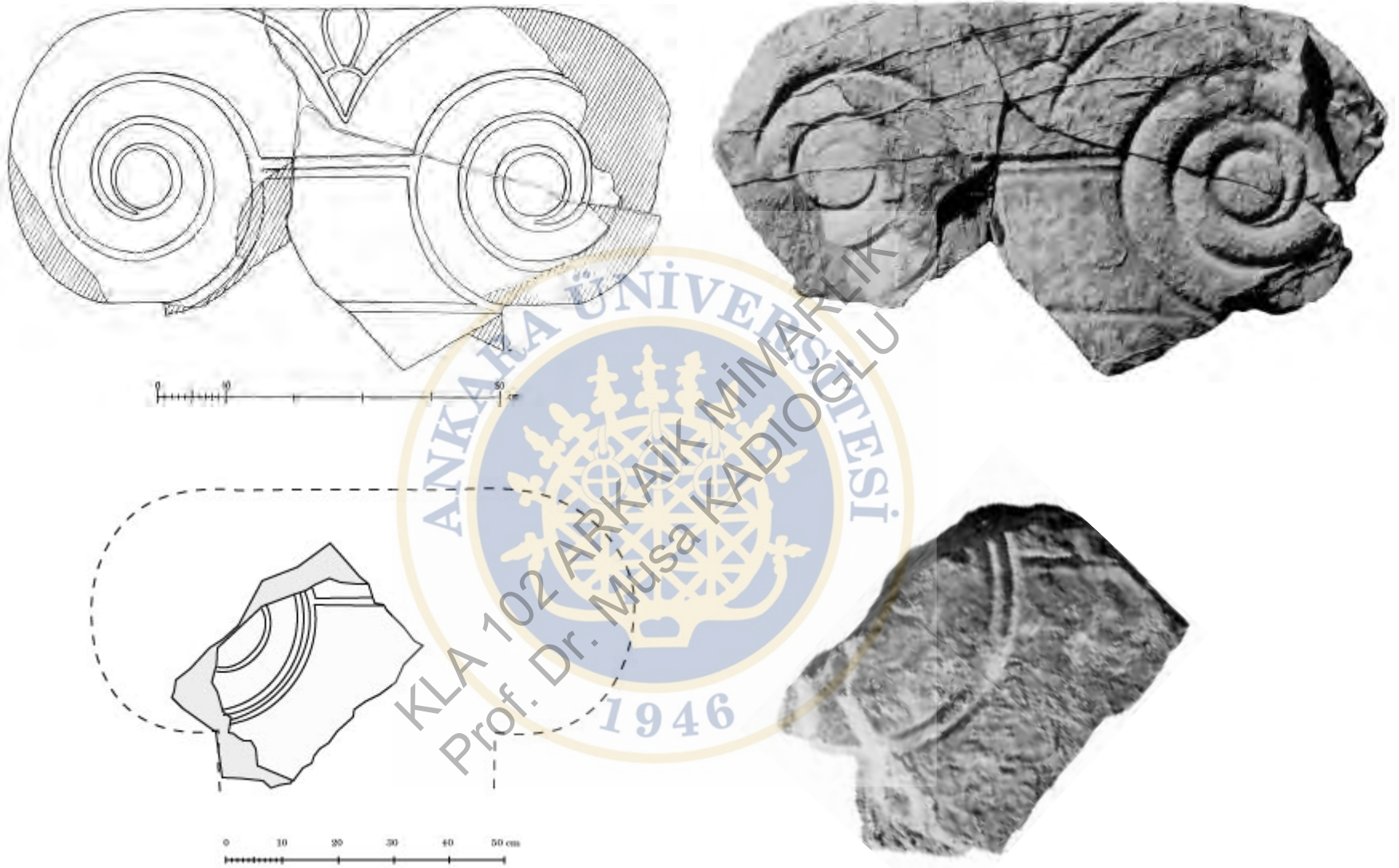

Alazeytin 31 numaralı yapı, MÖ 550-525



Abb. 163, b. Alt-Smyrna. Athenatempel.
Volutenkapitell o. Rekonstruktionsvor-
schlag des Verfassers (Zeichnung: Murat
Erdim)

Bayraklı Athena Tapınağı, Aeol başlıklar ile sütunlar, MÖ 600



Abb. 43 Alt-Smyrna. Athenatempel.
Kapitell A. Tuffstein. Um 600 v. Chr.
(Aufnahme und Zeichnung: Meral Manyas)



Abb. 44 Alt-Smyrna. Athenatempel.
Kapitell B. Tuffstein. Um 600 v. Chr. Aus
Dutzenden Fragmenten zusammengesetzt
von Orhan Bingöl (Aufnahme und Zeich-
nung: Meral Manyas)

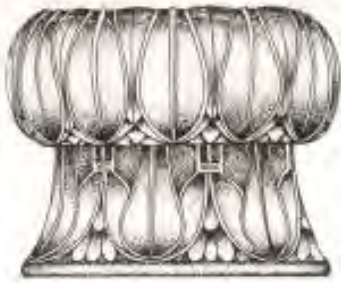

Abb. 45 Alt-Smyrna. Athenatempel.
Kapitell C. Tuffstein. Um 600 v. Chr. Aus
Dutzenden Fragmenten zusammengesetzt
von Meral Manyas (Aufnahme und
Zeichnung: Meral Manyas)



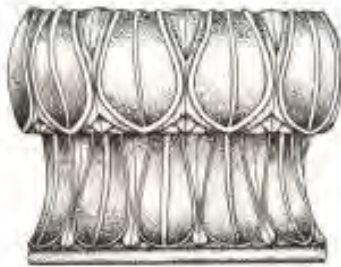

ANKARA ÜNİVERSİTESİ
MİMARLIK BÖLÜMÜ
Prof. Dr. Musa KADIOĞLU
1946

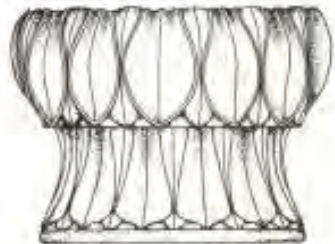
Smyrna Athena Tapınađı Mantar Bařlık



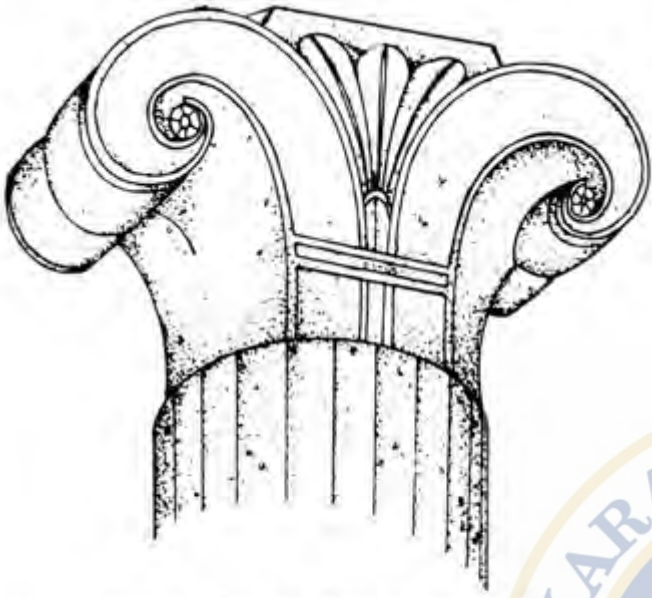

Res. 7 Smyrna Athena Tapınağı.
Dikey volütlü başlık, tüftaşı.
MÖ 7. yüzyıl son dörtlük.

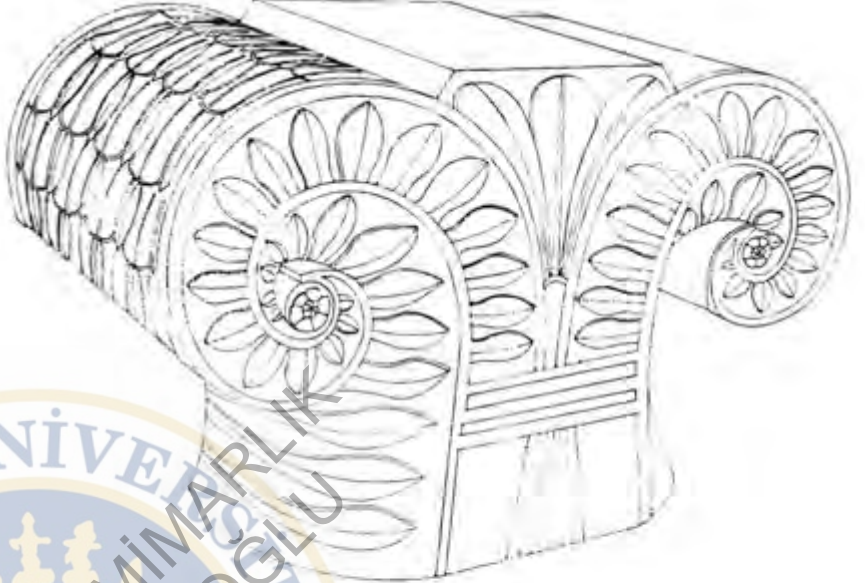

Res. 8 Smyrna Athena Tapınağı.
Dikey volütlü başlık, tüftaşı.
MÖ 7. yüzyıl son dörtlük.

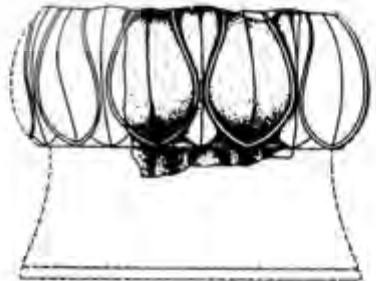
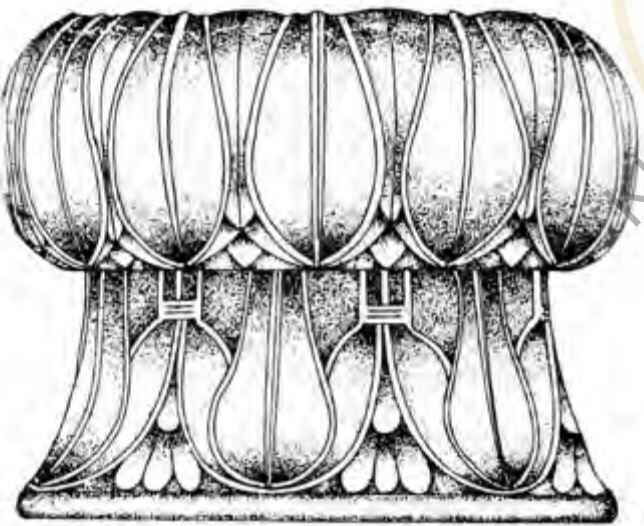

Res. 11-13 Smyrna Athena Tapınağı. Mantar biçimli A-C başlıkları.
MÖ 7. yüzyıl sonu.





Abb. 163, b. Alt-Smyrna. Athenatempel.
Volutenkapitell o. Rekonstruktionsvor-
schlag des Verfassers (Zeichnung: Murat
Erdim)



Bayraklı Athena Tapınağı, Aiol
başlıklar, MÖ 600

ANKARA ÜNİVERSİTESİ
KLA 102 ARKAIK MİMARLIK
Prof. Dr. Musa DİOĞLU
1946

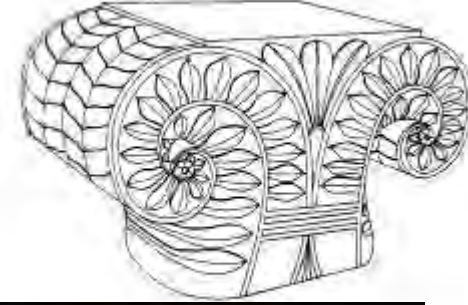
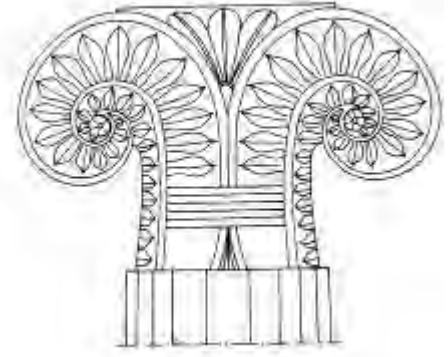
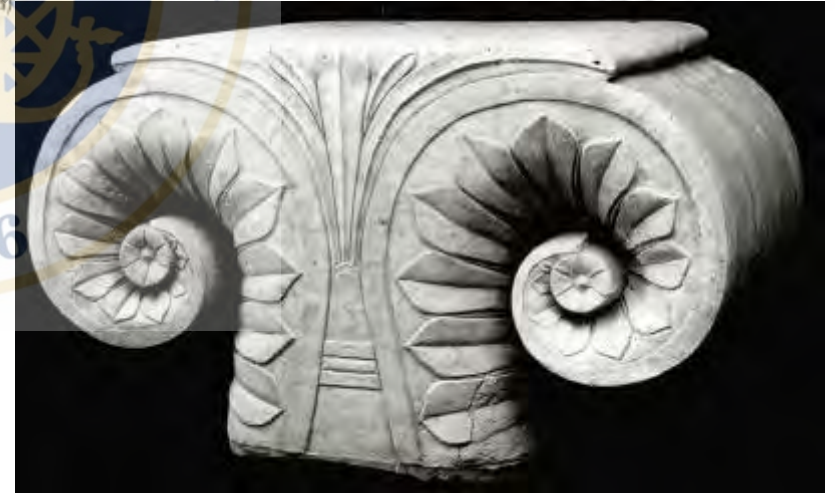

MÖ 600, Aeol-İon tipi sütun başlığı, Oropos

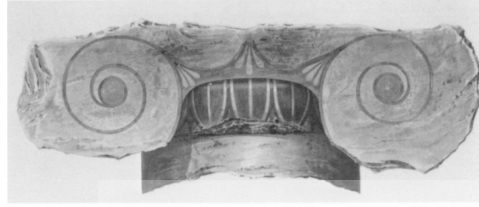
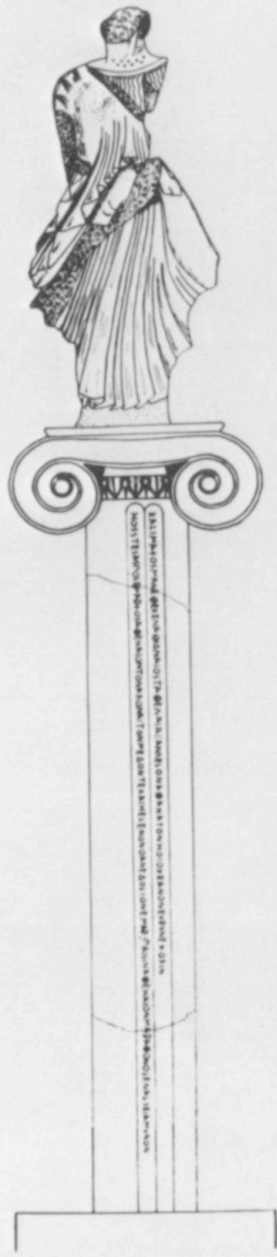

Atina Akropolü



Delphi Apollon Kutsal Alanı

LARİSA, Eski Saray

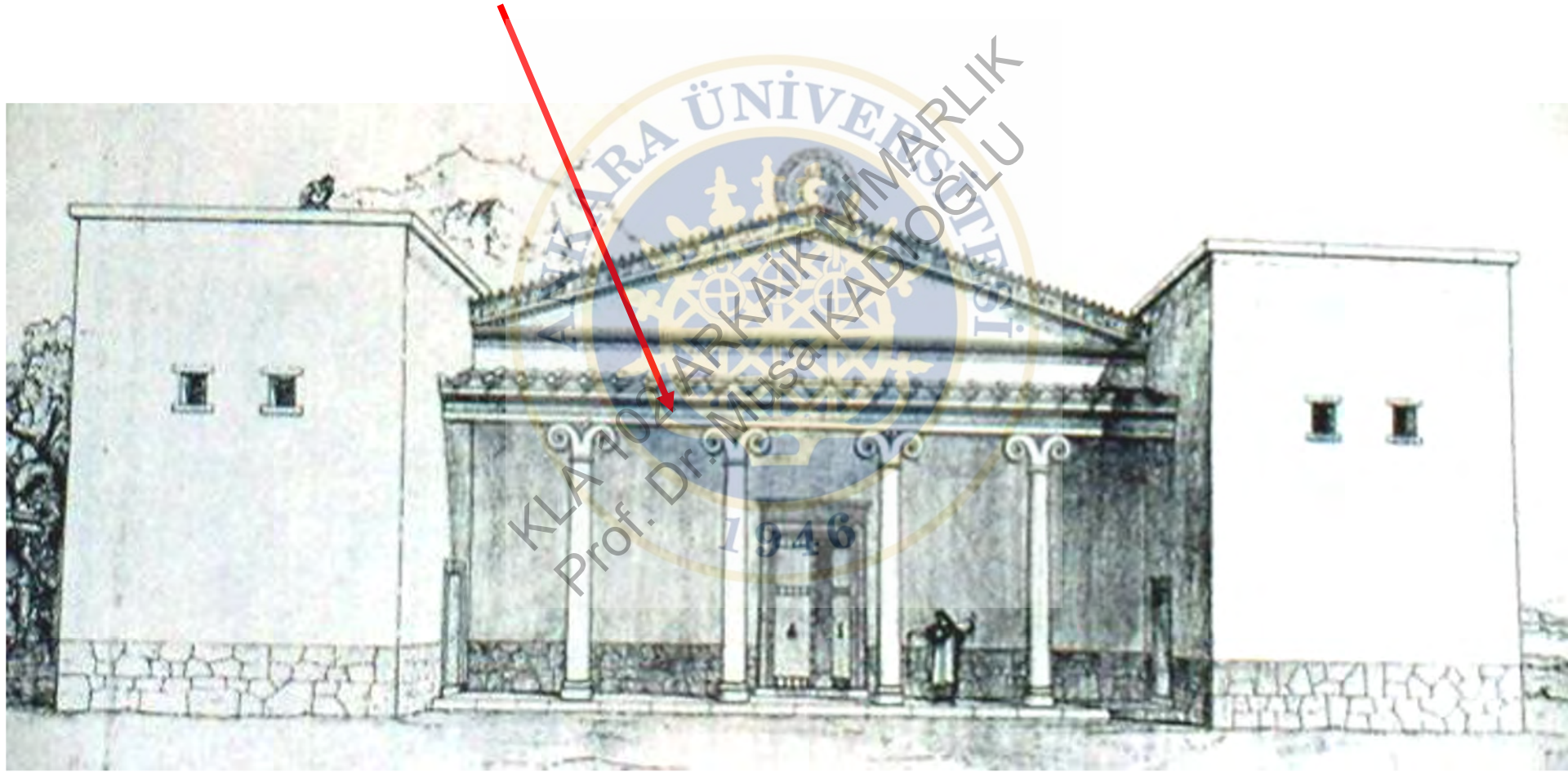



Figür-70



Figür-71

MİLLÎ MUSEYİNİN
ANKARA ÜNİVERSİTESİ
1946
Prof. Dr. Musa KADIOĞLU

Neandria Tapınağı (MÖ 6. yy başları)



Abb. 63 Grundriß des Tempels in Neandria. Ca. 600–575 v. Chr.



Fig. 32. — Sima de Néandria.

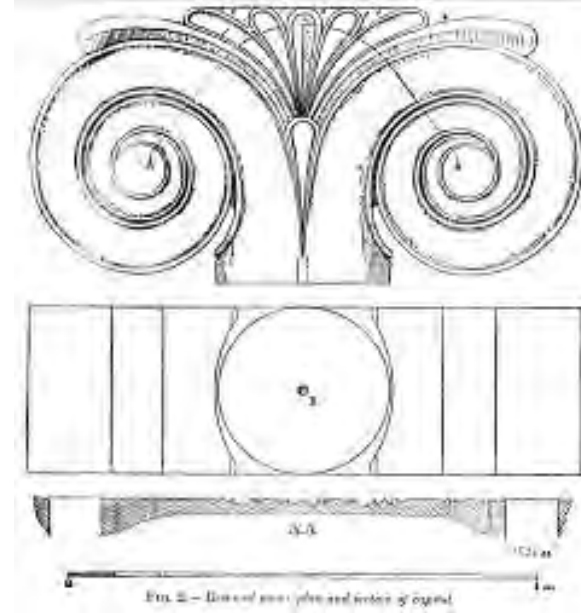

FIG. 2. — Detail of papyrus leaf and section of capital



Neandria Athena Tapınağı (MÖ 6. yy başları)

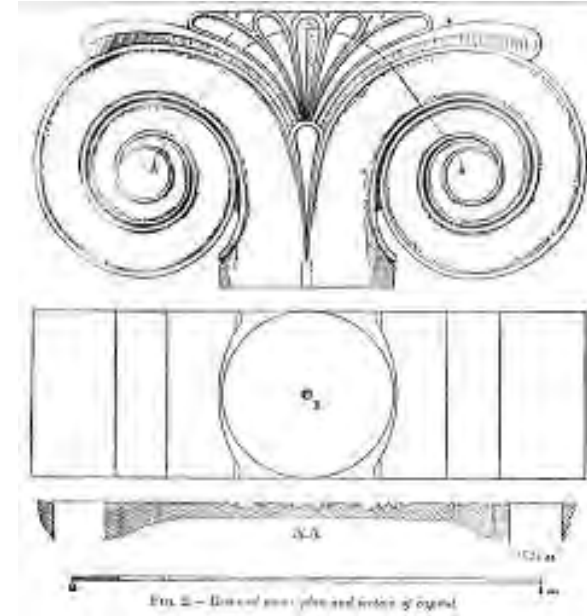

Fig. 2 — Crossed section (plan and section of capital)



Abb. 6 Grundriß des Tempels in Neandria. Ca. 600–575 v. Chr.



Fig. 32. — Sima de Néandria.



Neandria Athena Tapınağı, (MÖ 7. yüzyıl)

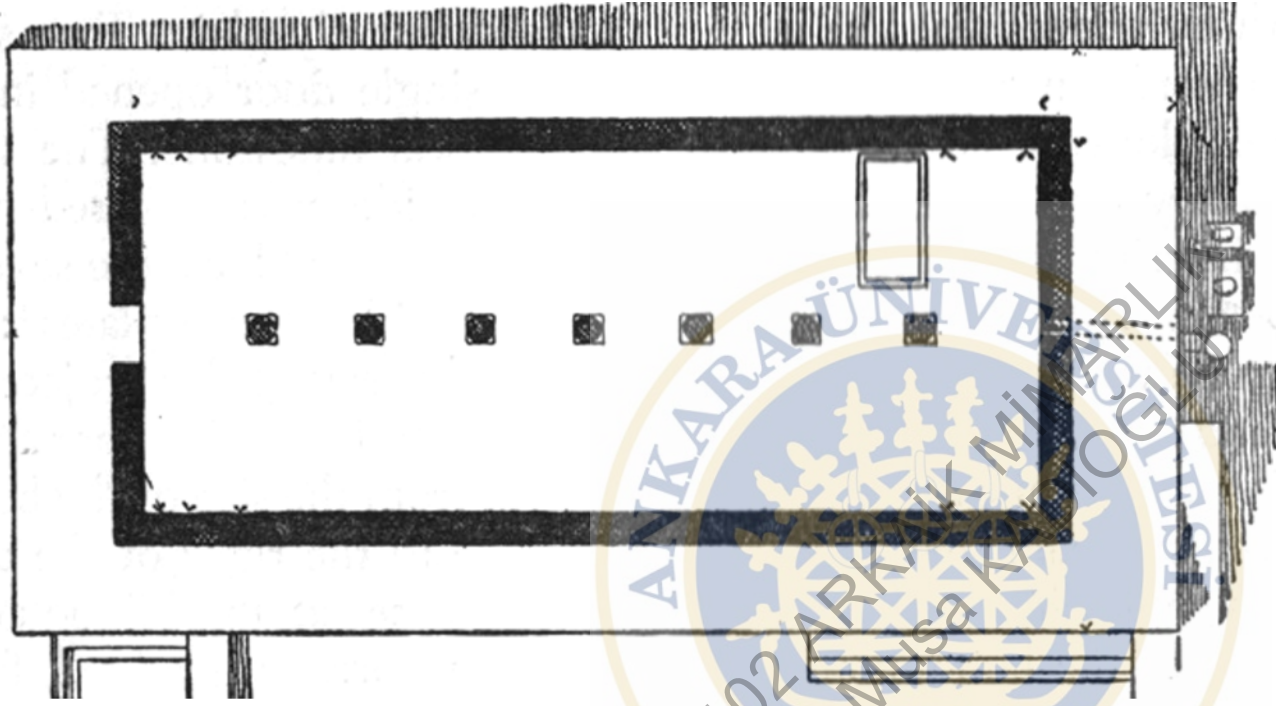

AEOL TAPINAKLARI

- 1.Smyrna Athena Tapınağı, Olgun Arkaik Dönem (MÖ 600-580)
- 2.Neandria Tapınağı (MÖ 6. yüzyıl)
- 3.Troia Arkaik Tapınak (MÖ 550)
- 4.Klopedi Tapınağı, Lesbos Adası, MÖ 6. yüzyılın ikinci yarısı

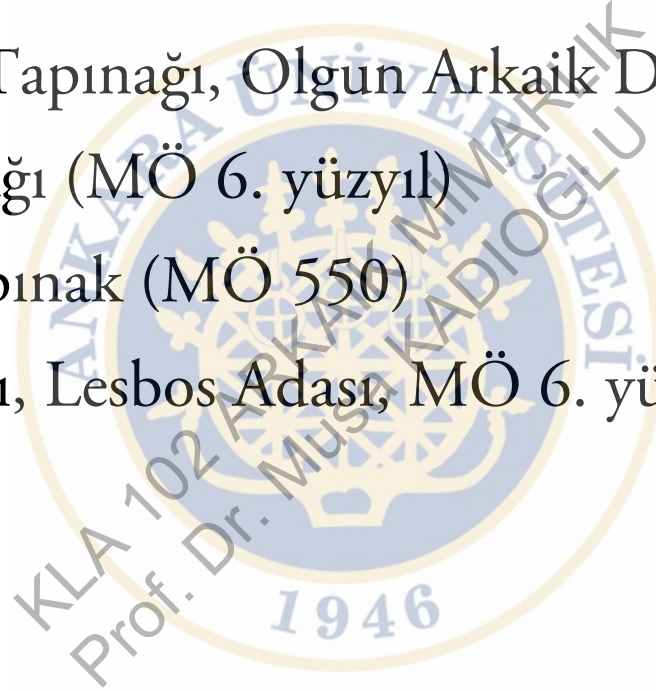

MÖ 7. yüzyılda Smyrna (Bayraklı/İzmir)

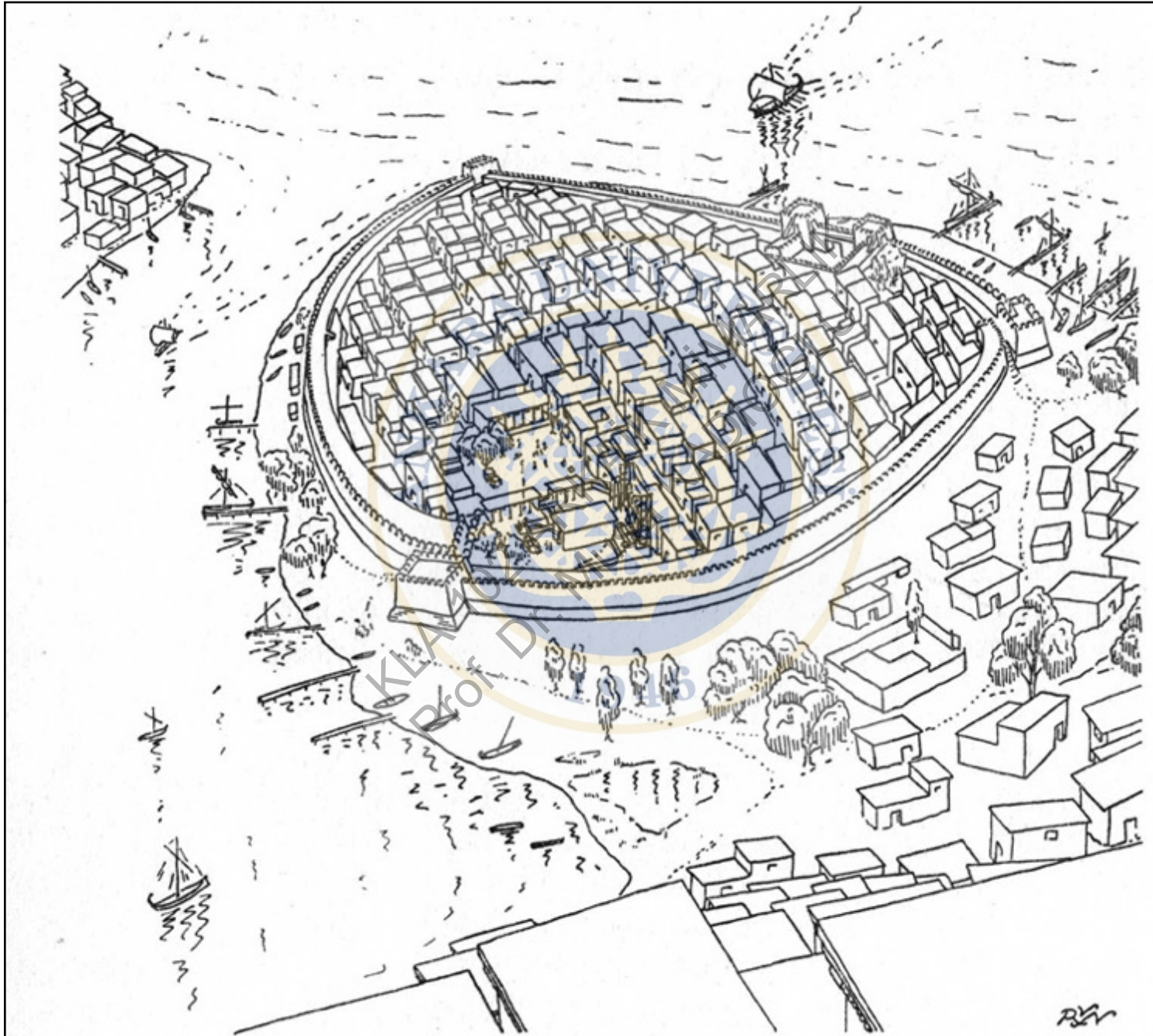

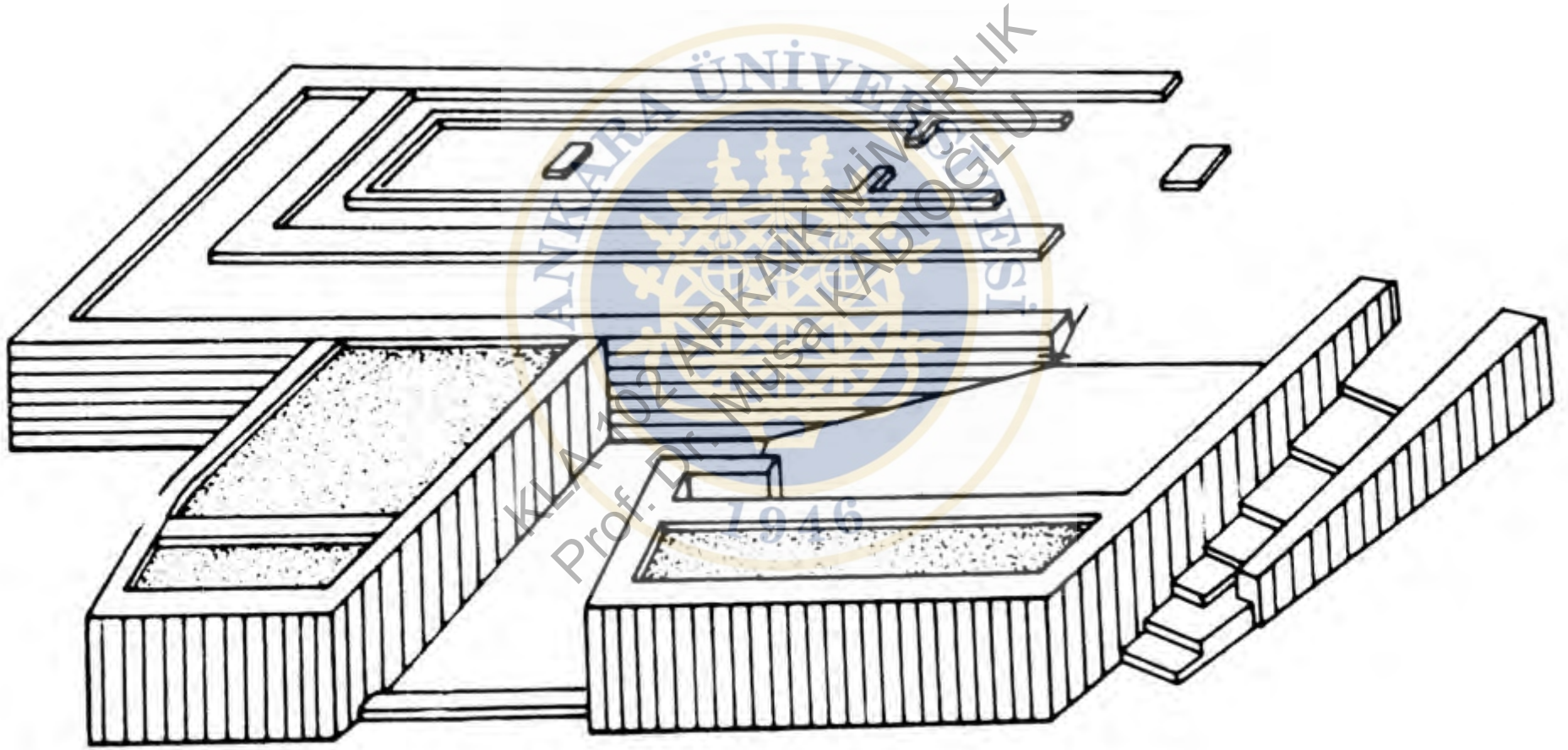

Res. 5 Smyrna Athena Tapınağı. Doğu ve Batı teraslar.
MÖ 7. yüzyıl son dördlük.

Smyrna Athena Kutsal Alanı (MÖ 600-580)

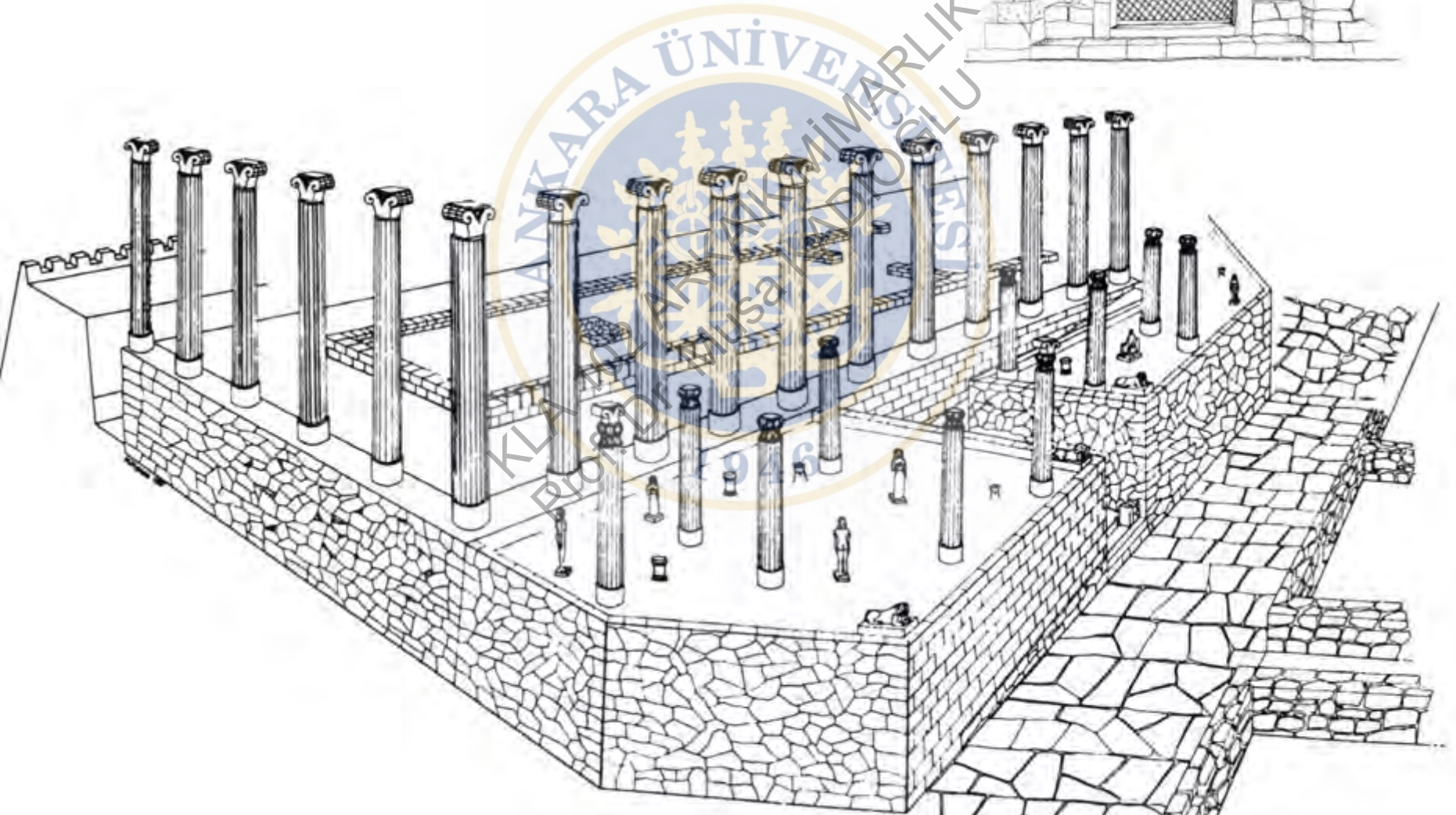
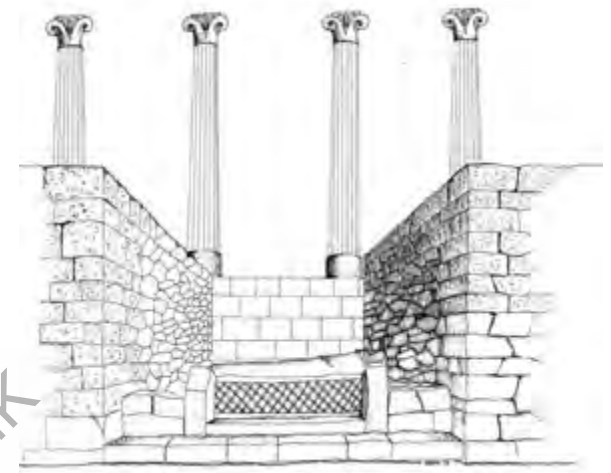

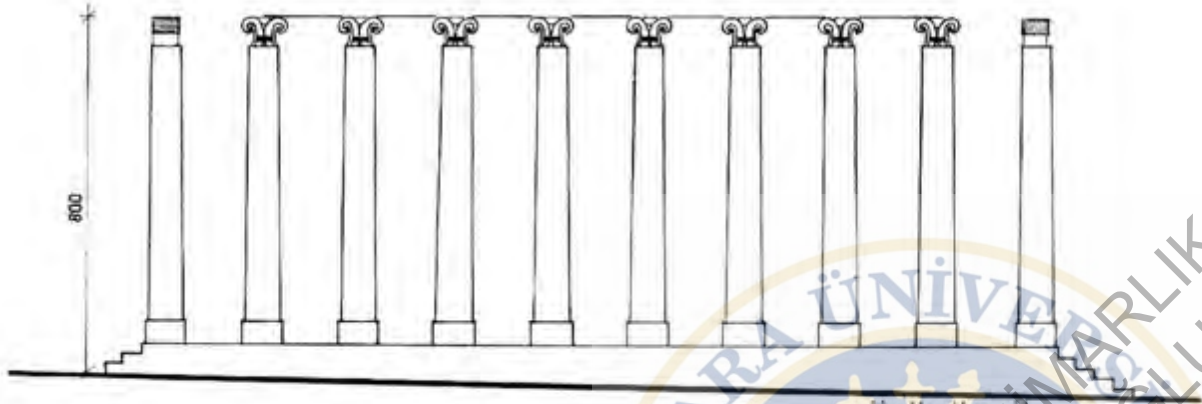

GÖRÜNÜŞ Ö:1/100

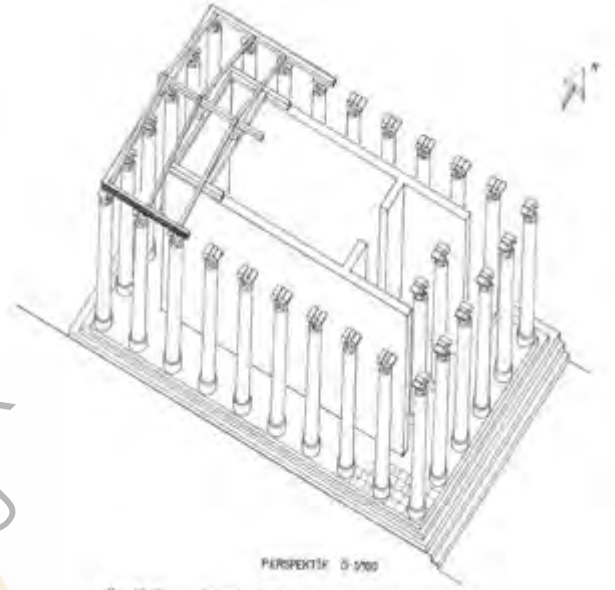

PERSEKTİF Ö:5/100

Res. 11 - Sıra, Erken Asaklı Dönem Tapınığı, II. Evre Öneri görünüşü

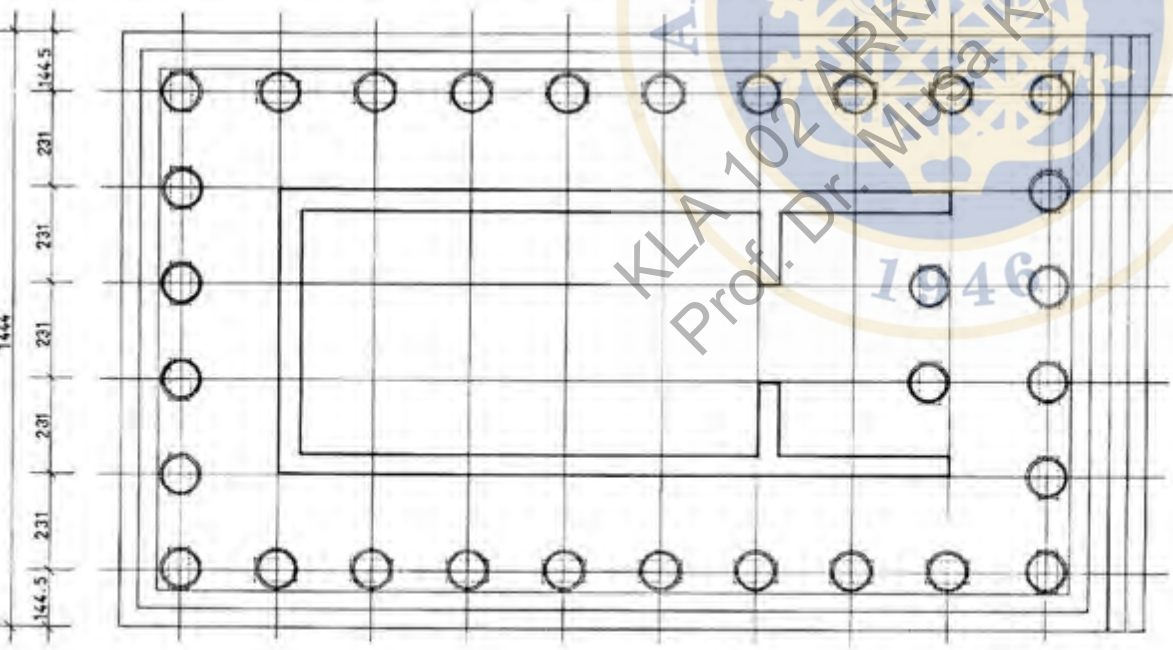

PLAN Ö:1/100

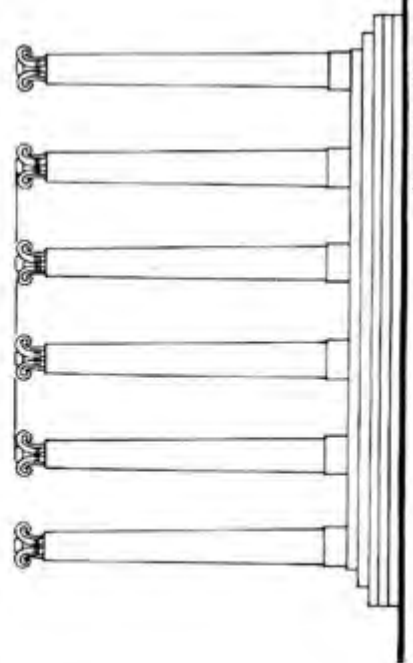

GÖRÜNÜŞ Ö:1/100

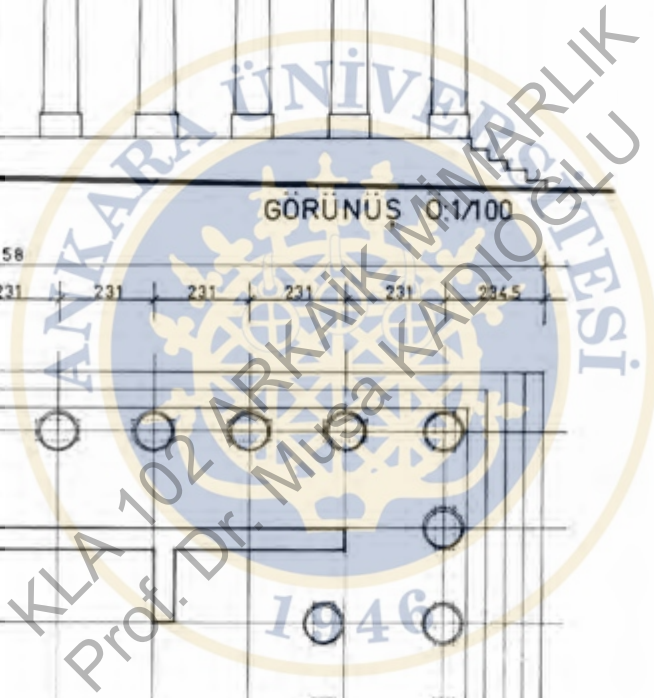



Abb. 163, b. Alt-Smyrna. Athenatempel.
Volutenkapitell o. Rekonstruktionsvor-
schlag des Verfassers (Zeichnung: Murat
Erdim)



Bayraklı Athena Tapınağı, Aiol
başlıklar, MÖ 600

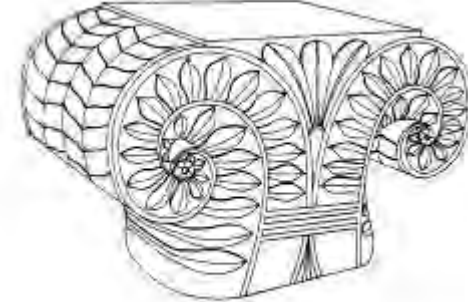
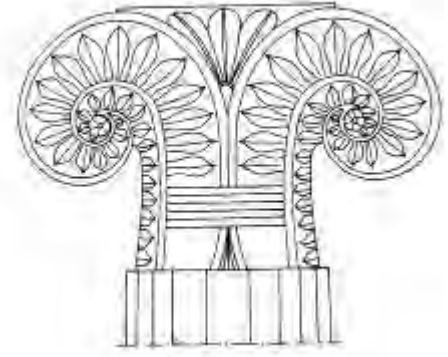
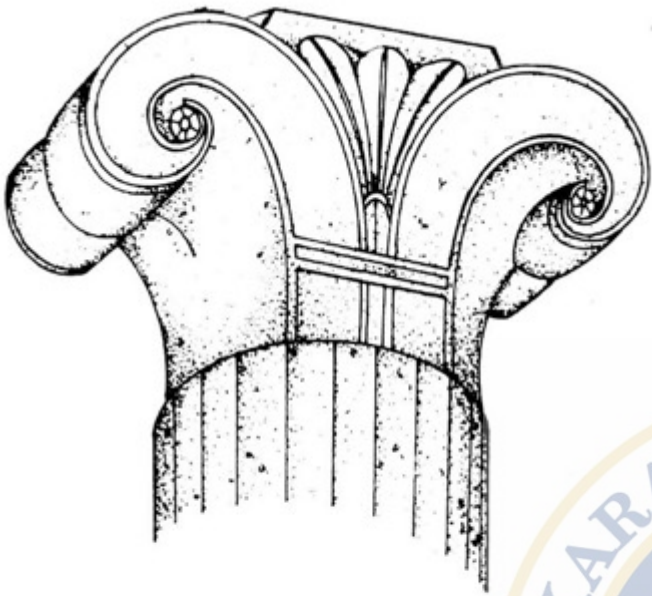

Res. 7 Smyrna Athena Tapınağı.
Dikey volütlü başlık, tüftaşı.
MÖ 7. yüzyıl son dörtlük.

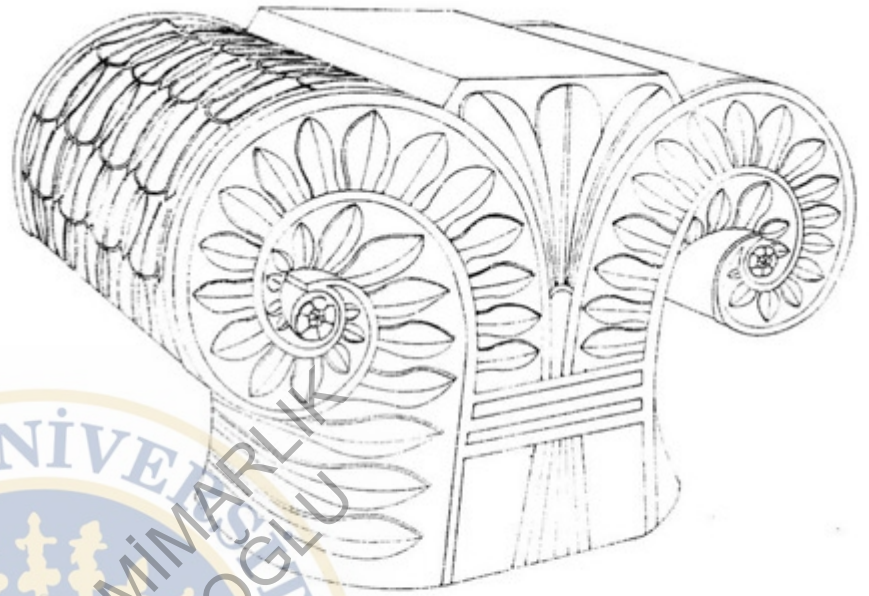

Res. 8 Smyrna Athena Tapınağı.
Dikey volütlü başlık, tüftaşı.
MÖ 7. yüzyıl son dörtlük.

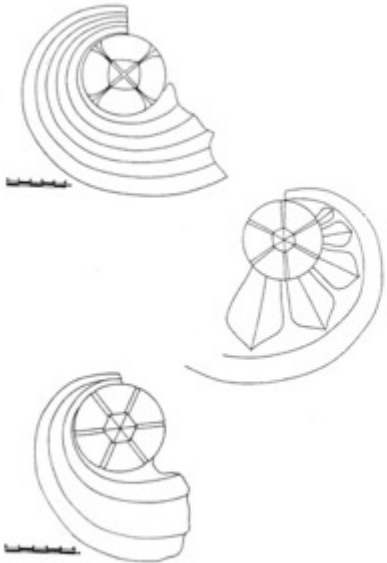

Res. 9 Smyrna Athena Tapınağı.
Dikey volütlü başlık örnekleri.

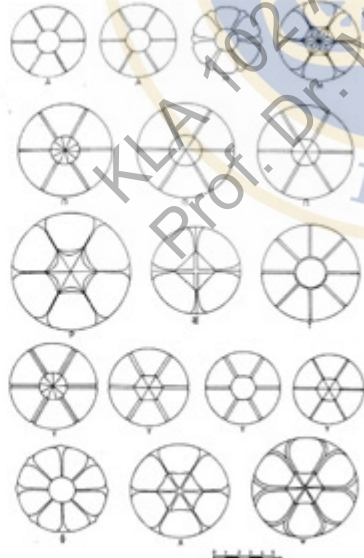

Res. 10 Smyrna Athena Tapınağı.
Dikey volütlü başlık rozetleri.





Fig. 1. Aiol sütun başlıkları. Pıçacılar (1946). Bir diğersinde malzeme çirtilik belirtilmiştir. Fiskel İzmit (Beyoğlu) MÜZ. s. 46/47. İsmail Arslan'ın Müzesi.

Bayraklı Aiol Başlıkları, MÖ 570



SMYRNA ATHENA TAPINAĐI



KAYNAKÇA

- 1- M. Akurgal, "Smyrna Athena Tapınağı", E. Okan– C. Atila (ed.), Ömer Özyiğit'e Armağan/Studies in Honour of Ömer Özyiğit (2015) 1-12.
- 2- E. Akurgal, *Eski İzmir I. Yerleşme Katları ve Athena Tapınağı* (Ankara 1993).
- 3- M. Akurgal, "Hellenic Architecture in Smyrna 650-546 BC", Frühes Ionien. Eine Bestandaufnahme Panionion Symposium Güzelçamlı 26 September - 1 Oktober 1999, Milesische Forschungen 5, 2007.
- 4- M. Akurgal, Smyrna Bayraklı Höyüğü. Bayraklı Belediyesi Kültür Sanat ve Tarih Yayınları I (2010).
- 5- J. K. Anderson, "Old Smyrna: The Corinthian Pottery, BSA 53/54, 1958/1959, 138-151.
- 6- L. Boardman - J. Dörig – W. Fuchs – M. Hirmer, Die griechische Kunst (1984).
- 7- J. M. Cook, "The History of Old Smyrna" BSA 53/54, 1958/1959, 9-27.
- 8- J.M. Cook – R.V. Nichols, "Old Smyrna Excavations. The Temple of Athena", BSA Suppl. 30, 1998.
- Y. Eran, Arkaik Dönem Tapınakları. Anıtsal Hellen Mimarlığına Giriş (İstanbul 2018) 438-447

Bayraklı: Aiol Kymationu. MÖ 570 İzmir Arkeoloji Müzesi

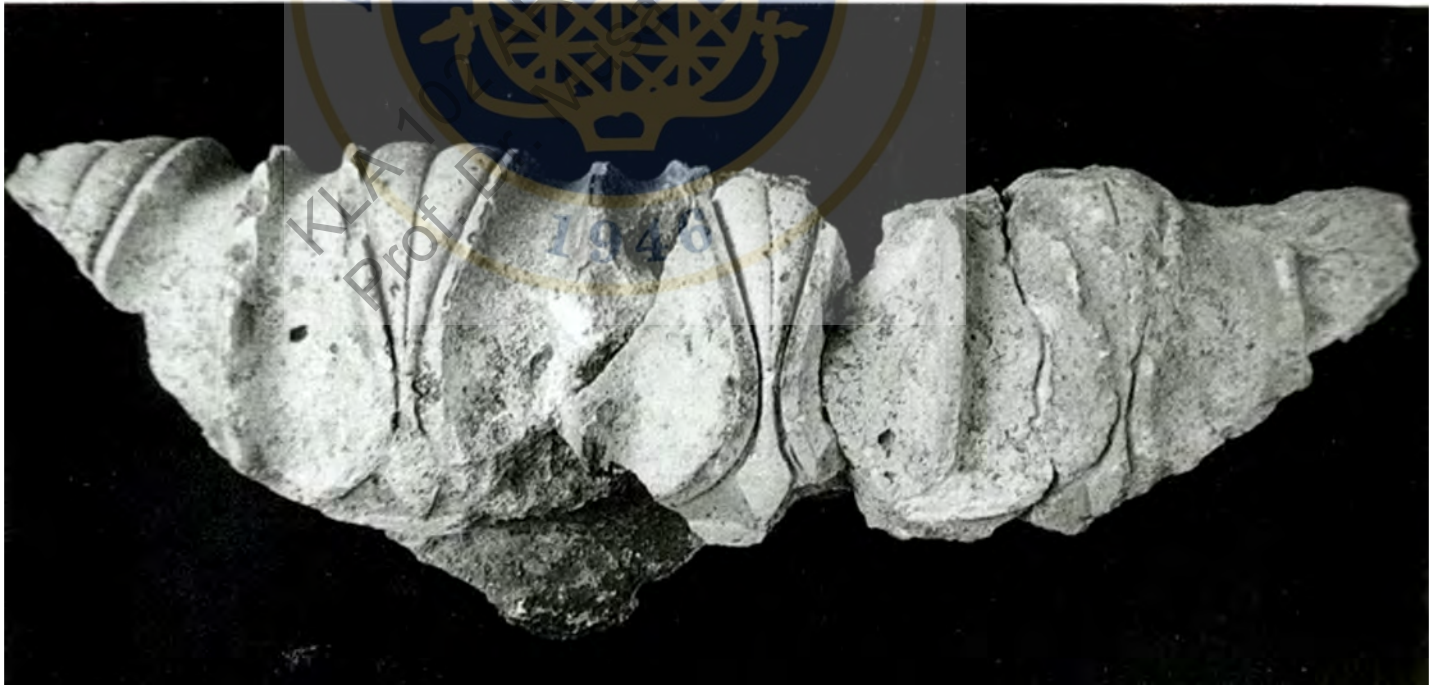

TEOS, Aeol Kymation Tacı (MÖ 550-530)

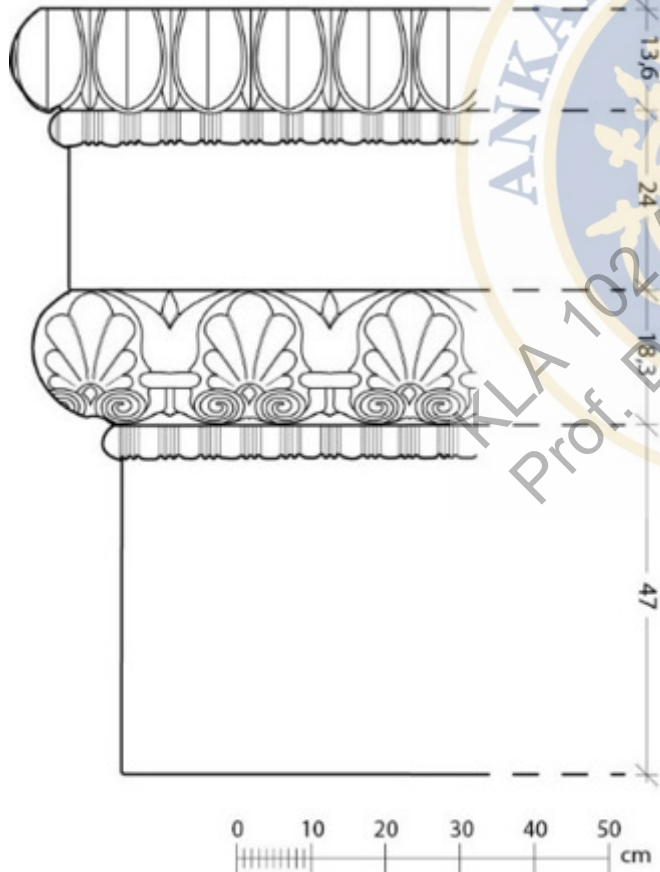

ANKARA ÜNİVERSİTESİ
MUSA ERGİ
1946
Prof. Dr. Musa Ergi

Lesbos, Mytilene



Pl. 50. Mytilene. Capital with double margins and eyes bored completely through the stone. Late sixth century B.C. or slightly later. By courtesy of the Archaeological Museum, Istanbul, no. 985.

Mytilene, Aeol Başlık, çift konturlu ve volüt gözleri boydan boya açılmış (MÖ geç 6. yüzyıl)



Pl. 51. Eressos. Aeolic capital with doubled volutes.
uncertain, no earlier than the late sixth century B.C.
courtesy of the Italian School of Archaeology in Athens.
After J. D. Condis, "Capitello eolico di Eressos," *ASAA*,
new series, 8-10 (1946-1948) fig. 1.

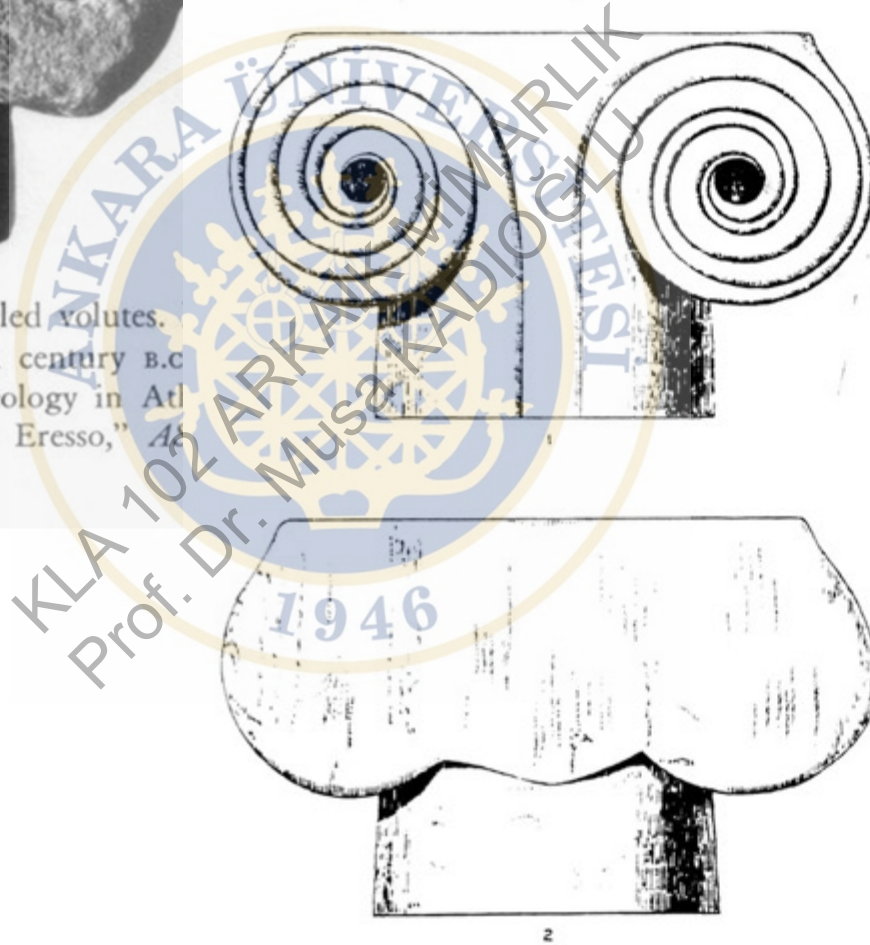

3

Lesbos, Eressos'ta
bulunmuş MÖ 6.yy
sonlarına tarihlendirilen
başlık

Fig. 43. The Aeolic capital from Eressos. By courtesy
of the Italian School of Archaeology in Athens, after
J. D. Condis, "Capitello eolico di Eressos," *ASAA*,
new series, 8-10 (1946-1948) fig. 2.