

Week 10. Fish Hatchery and Design

WHAT IS A HATCHERY?

A fish hatchery is a place for artificial breeding, egg hatching, and rearing across the early life stages of aquatic animals (e.g. finfish and crustaceans). The output of a hatchery is normally fry, fingerlings or juveniles (with the respective name depending on the life stage/age of the fish). These young small fish are then transferred to an on-growing section to reach harvest size.

A fish hatchery is a place for artificial breeding, hatching, and rearing through the early life stages of animals—finfish and shellfish in particular. Hatcheries produce larval and juvenile fish, shellfish, and crustaceans, primarily to support the aquaculture industry where they are transferred to on-growing systems, such as fish farms, to reach harvest size.

Some species that are commonly raised in hatcheries include Pacific oysters, shrimp, Indian prawns, salmon, tilapia and scallops. The value of global aquaculture production is estimated to be US\$98.4 billion in 2008 with China significantly dominating the market; however, the value of aquaculture hatchery and nursery production has yet to be estimated. Additional hatchery production for small-scale domestic uses, which is particularly prevalent in South-East Asia or for conservation programmes, has also yet to be quantified.

There is much interest in supplementing exploited stocks of fish by releasing juveniles that may be wild caught and reared in nurseries before transplanting, or produced solely within a hatchery.^[4] Culture of finfish larvae has been utilised extensively in the United States in stock enhancement efforts to replenish natural populations. The U.S. Fish and Wildlife Service have established a National Fish Hatchery System to support the conservation of native fish species.

Hatcheries produce larval and juvenile fish and shellfish for transferral to aquaculture facilities where they are 'on-grown' to reach harvest size. Hatchery production confers three main benefits to the industry;

1. Out of season production

Consistent supply of fish from aquaculture facilities is an important market

requirement.^[7] Broodstock conditioning can extend the natural spawning season and thus the supply of juveniles to farms.^{[7][8]} Supply can be further guaranteed by sourcing from hatcheries in the opposite hemisphere i.e. with opposite seasons.^[9]

2. Genetic improvement

Genetic modification is conducted in some hatcheries to improve the quality and yield of farmed species. Artificial fertilisation facilitates [selective breeding](#) programs which aim to improve production characteristics such as growth rate, disease resistance, survival, colour, increased fecundity and/or lower age of maturation.^[7] Genetic improvement can be mediated by [selective breeding](#), via [hybridization](#), or other [genetic manipulation](#) techniques.

3. Reduce dependence on wild-caught juveniles

In 2008 aquaculture accounted for 46% of total food fish supply, around 115 million tonnes.^[2] Although wild caught juveniles are still utilised in the industry, concerns over sustainability of extracting juveniles, and the variable timing and magnitude of natural spawning events, make hatchery production an attractive alternative to support the growing demands of aquaculture.^{[2][7][10]}

Hatchery Design

Hatchery designs are highly flexible and are tailored to the requirements of site, species produced, geographic location, funding and personal preferences.^[7] Many hatchery facilities are small and coupled to larger on-growing operations, whilst others may produce juveniles solely for sale. Very small-scale hatcheries are often utilized in subsistence farming to supply families or communities particularly in south-east Asia.^[3] A small-scale hatchery unit consists of larval rearing tanks, filters, live food production tanks and a flow through water supply.^[3] A generalized commercial scale hatchery would contain a broodstock holding and spawning area, feed culture facility, larval culture area, juvenile culture area, pump facilities, laboratory, quarantine area, and offices and bathrooms.^[8]

HATCHERY DESIGN AND CONSTRUCTION

A marine fish breeding centre is a complex facility. Because of its zotechnical characteristics, during the production season proper hatchery management requires uncommon skills and total dedication by

well-trained personnel. Therefore, in designing a fish hatchery only those technical solutions that offer the best guarantees in terms of reliability, ease of use, production capacity, hygienic working conditions and cost effectiveness have to be used.

Gross mistakes in design and/or construction can risk a full production season even before it is started. In addition, temporary solutions always carry the risk of far from optimal rearing conditions, leading to disease outbreaks in fish larvae.

This second part of the manual deals with the principles and guidelines for the design and construction of a commercial hatchery for gilthead seabream and seabass.

This chapter describes how to calculate the size of the hatchery and how to select the appropriate site. It also deals with the design of production facilities. The function and the selection of hatchery systems and technical equipment are also described, focusing on the most widely adopted technical solutions in Mediterranean hatcheries. Special attention is given to the description of the seawater intake, and to water distribution, recirculation and treatment systems, as they are among the most sensitive components of the hatchery.



1.1 CALCULATING THE SIZE OF A HATCHERY

In order to design a marine fish hatchery, the investor has to have a clear idea about its production target. A decision on the size of the hatchery is a fundamental pre-requisite before starting the search for suitable sites, or before starting the technical design or the financial plan.

In particular, the following issues should be addressed:

- main fish species (seabass, gilthead seabream or both),
- secondary species (other fish, clams, shrimps),
- yearly targets as number and size of fry of each species considered,
- origin of eggs (internal production or from other sources),
- whether photoperiod and thermoperiod manipulation to shift reproductive cycles is planned,
- marketing aspects (fish size and season for sales).

Any aspect not properly considered during the planning phase may result in difficult working conditions later on, requiring costly interventions to correct them (if at all possible) and causing production interruptions.

1.2 SITE SELECTION CRITERIA

The Mediterranean region is not uniform. Environmental conditions along its coastline vary considerably. Habits, customs and technical development of the countries bordering it also show large differences. The analysis of these local factors is the initial step in the process of proper design of a hatchery. In fact, the above mentioned aspects play a crucial role in relation to the technical feasibility, but also in keeping the running costs within manageable limits.

It may seem absurd, but the vast majority of Mediterranean hatchery sites were not decided on the basis of a thorough selection process, but were often already set at the beginning of the project. This absence or scarcity of options is common both in private and public projects. In the first case, the investor usually owns the site, whereas in the public hatcheries, local and political reasons may influence the selection of a particular location regardless of technical considerations.

In any case, when looking for a new site or when collecting information on a preselected location, the reconnaissance process should consider several well-defined aspects which fall under two broad categories: the natural environment and the socio-economic environment.

1.3 ENVIRONMENTAL FACTORS

A list of the main environmental parameters to be considered is given below. As a rule, historical series of data collected by national services (meteorology, oceanography, soil, etc.) provide more reliable information than local interviews or spot measurements, which, however, are a useful tool to make a first evaluation of the site.

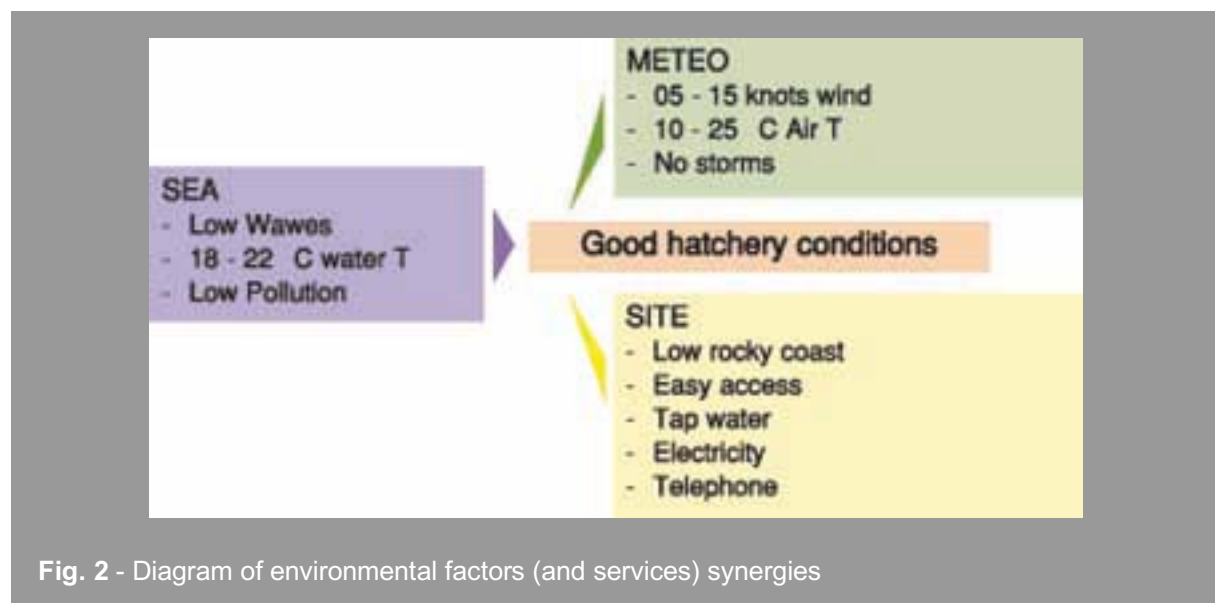

Fig. 2 - Diagram of environmental factors (and services) synergies

Sea conditions

- *Seawater temperature* is one of the most important parameters because it influences critical design components such as a seawater intake system (open or semi-closed circuit) and the heating system. It may also have an influence on operating costs and as a consequence, on the overall economic feasibility of the project. In the Northern Mediterranean, due to the fact that both seabass and gilthead seabream breed during the winter and early spring period, the rather low winter seawater temperatures mean that water heating is necessary to reduce larval rearing time.

- *Waves* (amplitude, length, direction, seasonal and storm conditions) coastal currents (magnitude, direction and seasonal variations) and tides (ranges, seasonal and storm variations, oscillations) are key factors to be considered when designing the sea water intake. They also have importance on seawater quality when pollution sources exist, even if they are located far away. Whenever possible, it is important to collect historical data series on these parameters from public authorities or other relevant sources. Local sources should be considered only when no other information is available, or to confirm collected data.
- *Seawater quality*, despite a common misconception, is usually suitable for hatchery operations in most of the Mediterranean. Sites to be avoided are those affected by severe industrial and domestic pollution. Such areas are found close to large industrial installations, towns, harbours or in river deltas or estuaries. Well-water, though interesting as it tends to have a more uniform temperature throughout the year and far lower investment costs for extraction, is not free from potential danger. It should provide a constant and reliable flow and be free from pollutants such as ammonia, sulphur compounds, heavy metals and pesticides. To a certain extent, specific treatment can improve its quality, but where dangerous heavy metals are present, their elimination is very difficult.

Meteorological factors

- *Winds. Prevailing direction and speed.* The occurrence of strong winds or seasonal storms has a great influence on hatchery design. Apart from building characteristics planned for windy areas, the main problem is the protection of the sea water intake, in particular, if it is located in an open area. Its design and size are directly linked to the occurrence of big waves and strong currents caused by storms. The seawater quality is also severely affected by strong water movements that resuspend sediments. According to the type of sea floor, the amount of suspended solids may increase dramatically under bad weather conditions. A site located in a bay sheltered from the dominant winds has important advantages, such as the absence of strong waves and currents. Under these circumstances, the construction of the water intake is considerably simplified, as is the treatment of seawater (sedimentation and mechanical filtration). On the other hand, protected bays may suffer from low water exchange, which means waste water must be discharged far enough from the water intake to avoid any self-contamination. The cooling effect of wind in relatively shallow sites is something that should not be underestimated.
- *Maximum storm intensity and frequency.* The seawater intake is the most fragile part of the hatchery and the first to be affected by an exceptional storm. Due to its usually considerable cost, the design of intake facilities should take into account sea conditions under the strongest storm recorded in a period of 50 years at the location that is being evaluated.
- *Air temperature.* In many Mediterranean sites, air temperature is an important factor. Low air temperatures in winter do affect operating costs of the hatchery, and efficient thermal insulation will be required to keep internal air temperature around 18 to 20°C. The use of heated air blowers for the hatchery also provides the necessary ventilation. Air extractors should be combined with such blowers to reduce humidity levels inside the hatchery.
- *Solar energy.* Together with air temperature, it contributes to the thermal balance of the hatchery system. If considered at design stage, it may allow relevant savings in terms of investment and running costs. In the case of hatcheries totally or partially built in a greenhouse, shades and ventilation should be provided in late spring, summer and early autumn, according to the location, to prevent overheating.

Site related factors

- *Coast morphology.* It affects hatchery design and construction mainly in three ways: in providing a sufficiently flat area for the buildings, in relation to the design of the seawater intake system and for seawater quality. Low sandy coasts provide plenty of space, but the water intake typically requires expensive protection (breakwaters, long inlet channels, sedimentation tanks) to prevent clogging and to minimise sand and detritus uptake. A rocky coast usually has better water quality (absence of suspended solids, quicker return to normality after a storm) and simpler and cheaper water intake designs are possible, but its hard soil complicates the construction of structures requiring excavation. The height of the coast above sea level should also be considered, since higher sites will mean, for a given flow, larger pumping stations and

higher operational costs. In both cases, locations exposed to high waves and strong currents should be avoided due to the expensive works needed to protect the water intake.

- *Site accessibility.* Places isolated from the road network will require approach roads, which represent an additional cost that has to be carefully evaluated.
- *Availability of facilities such as electricity, telephone and potable water networks.* A connection to the high voltage electricity network is a prerequisite, whereas a link to potable water networks could be replaced by alternative solutions. Nowadays, a permanent telephone connection can be replaced by the use of cellular phones, although operating costs would be higher.
- *Sources of pollution from human activities* (large settlements, industrial activities, intensive agriculture, other fish farms in particular). The selection of the hatchery location should take into account the presence of important urban settlements, industrial harbours and large factories, which are sources of pollutants and could compromise water quality conditions. When intensive agriculture or industries are present in the coastal watershed they will produce pollutants that will be discharged by rivers in the coastal areas.
- *River discharges.* Even in the absence of pollution from human activities, river discharges carry sediments from surface run-off, that may contribute to excessive silting. This can rapidly clog the seawater intake, or worsen the quality of seawater at the pump intake.
- *Availability of freshwater (not potable).* Freshwater is needed in a hatchery, especially if salinity has to be lowered or rearing water has to be cooled.
- *History of site: prior uses and experiences.* Previous uses of the sites may have an impact. Abandoned industrial areas or former warehouses and dumping sites should be carefully checked for contaminants in both soil and on the beach before deciding on a site.

1.4 INTEGRATION OF SOCIAL, ECONOMIC, LEGAL AND TECHNICAL ASPECTS

Site selection is also greatly influenced by social, economic and legal aspects.

At present, a hi-tech approach in the design of a marine fish hatchery can assure a viable economic operation, keeping production costs to a minimum and optimising control procedures for the whole production process. However, a hi-tech approach is not always possible in specific locations, both in terms of the necessary technical support, availability of assistance, services, equipment and consumables, and also in terms of socio-economic characteristics such as available manpower, political acceptance, and local traditions and habits.

Technical service and repair. Even simple equipment such as pumps, air blowers, lights, filters and sterilizers, needs servicing. The local availability of qualified personnel able to provide specialised maintenance and to intervene quickly in case of breakdown of equipment should be evaluated. Proper maintenance also requires the availability of essential spare parts: shops or agents representing the producers of the main equipment should also be easily accessible and their reliability should be carefully checked. If available, and of similar characteristics, locally-produced equipment is best because it is cheaper and easier to service.

Building materials. The materials used to build the hatchery depend strictly on the local level of industrial development and local construction standards. The choice between pre-fabricated or brick buildings should be made only after comparing local construction costs and maintenance costs.

Manpower. Marine fish hatcheries require skilled labour. The local availability of qualified manpower should be evaluated. This is also linked to the relative importance that aquaculture has in the country. That may be reflected in high school or post-graduate specialisation, fish industrial production, or aquaculture research programmes. Previous experience with fish rearing should be essential requirements for the staff. If such experience does not exist in the country, the time and cost necessary to train farm personnel will have to be taken into account.

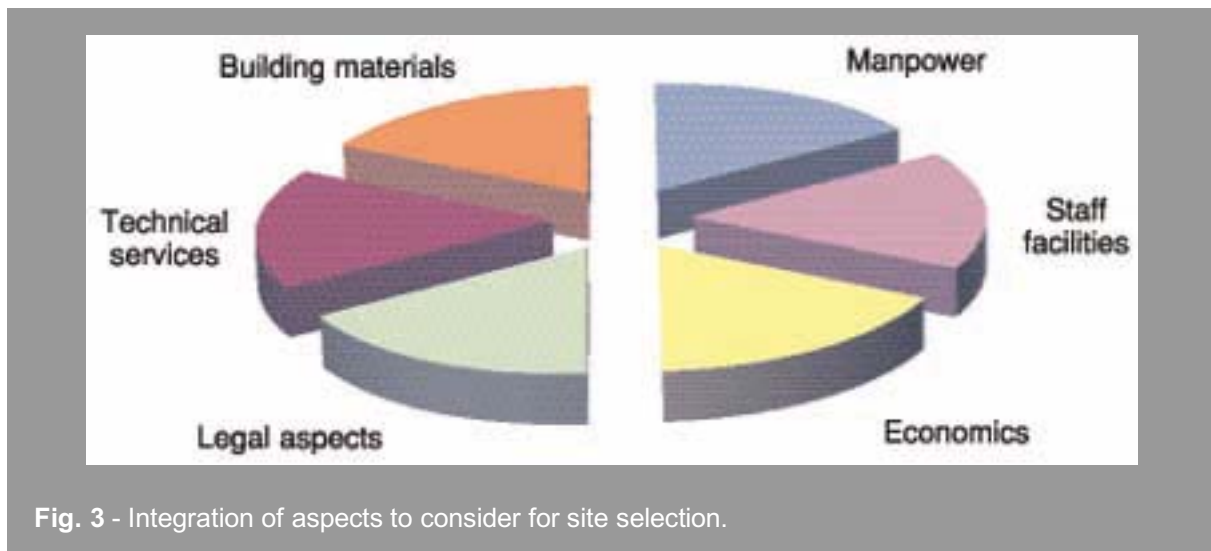

Fig. 3 - Integration of aspects to consider for site selection.

Staff and management facilities. When the hatchery is to be sited far away from inhabited areas, adequate accommodation should be provided for the staff. For sites that are far from important cities, provision of external technical assistance, as well as the supply of consumables (fish feed, chemical products and equipment spare parts) will become more difficult. A well-equipped workshop and adequate storerooms should then be included in the hatchery design.

Legal aspects and permits. All kinds of constraints for the use of the area, either existing or foreseeable, have to be investigated. Military, archaeological and historical areas usually mean hatcheries cannot be built but other land uses, such as wildlife protection and natural parks, may coexist with the fish hatchery. In addition, the hatchery should comply with all local legislation and regulations concerning constructions, such as maximum height/length, total volume allowed, limitations on the use of some materials and so forth.

The existence of local development plans should be verified. The planned use of the coastal area where the hatchery is to be built has to be compatible with fish farming. The existence of limitations to a possible future expansion of the hatchery, such as property boundaries under different ownership, should also be checked.

Economics. The greatest attention should be given to the financial analysis of the project to verify if it is economically sound. Economic factors also influence the general aspects of the hatchery design. A high cost of land will be an incentive to design more compact structures in order to save space. A high labour cost will lead to maximum automation of working processes to reduce manpower. A high market value of the produce will privilege high investments and the development of more technologically advanced production plants. In several Mediterranean countries, grants or loans with lower interest rates than standard loans are available for new enterprises, making more cost-effective production models possible.

1.5 EXISTING FACILITIES

The possibility of making use of existing facilities to set up a hatchery, is often an advantage. Sometimes, especially when existing industrial buildings have to be reconverted, the permission for land use is already awarded and most of the needed services (e.g. energy, freshwater, telephone lines) are already available. This is usually attractive for the investor and it is often the main reason to decide to build a hatchery on an existing facility. But a more accurate evaluation of the advantages offered by the pre-existing facilities should always be carried out, with particular emphasis on the possible presence of pollutants in the building, soil and facing sea area, as described above. The advantages offered by the use of pre-existing facilities should be carefully considered. Adaptation of the production process to the existing site should never compromise the basic technical criteria applied to hatchery design.

1.6 HATCHERY LAYOUT

The hatchery layout (Fig. 5) is presented following its production units. Criteria to be adopted rather strictly for architectural and engineering solutions are:

- overall economic feasibility of the project with cost effective solutions,
- rational exploitation of available space and energy,
- rational choice of materials and equipment,
- maximum technical reliability, achieved through a correct choice of equipment and the organization of its maintenance,
- reliability of production methods, obtained through adoption of standard working methodologies based on proven production techniques, efficient use of resources at disposal and ergonomics,
- easy servicing and maintenance,
- adopt flexible solutions to enable future technical upgrading,
- ensure optimal hygienic conditions.

The description of hatchery production systems is divided into two main components:

- the production units, where true production activities take place;
- the service units, which provide the necessary support to production units.

1.7 BROODSTOCK UNIT

The function of this unit is the proper maintenance of adequate stocks of parent fish to assure a timely supply of fertilized eggs of the best quality to the larval rearing sector.

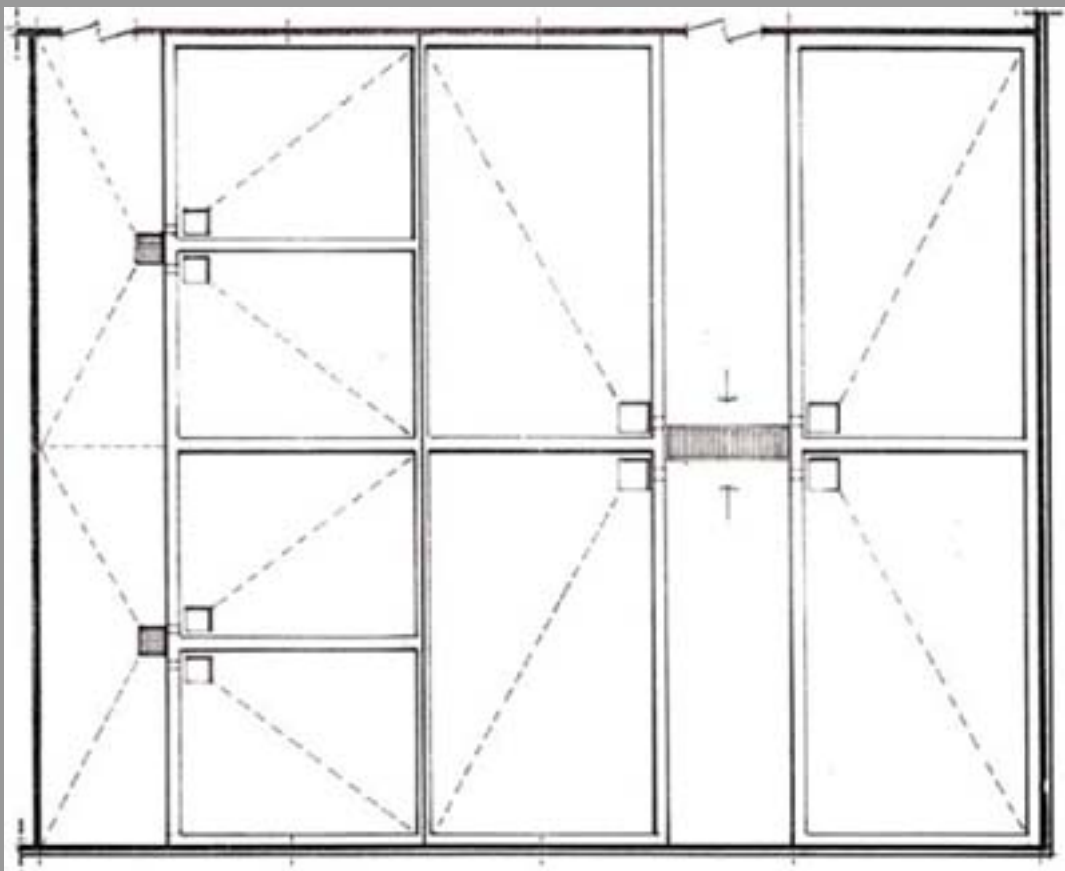

Fig. 4 - Plan of broodstock stocking and spawning section

Broodstock units have facilities placed both outdoors and indoors. Outdoors facilities are mainly used for long term stocking purposes, but also for quarantine treatments and to recover spent or newly captured breeders. Indoor facilities are mainly used for:

- overwintering, where severe winter conditions could affect fish survival,
- shifting reproduction periods by manipulation of temperature and photoperiod,
- spawning.

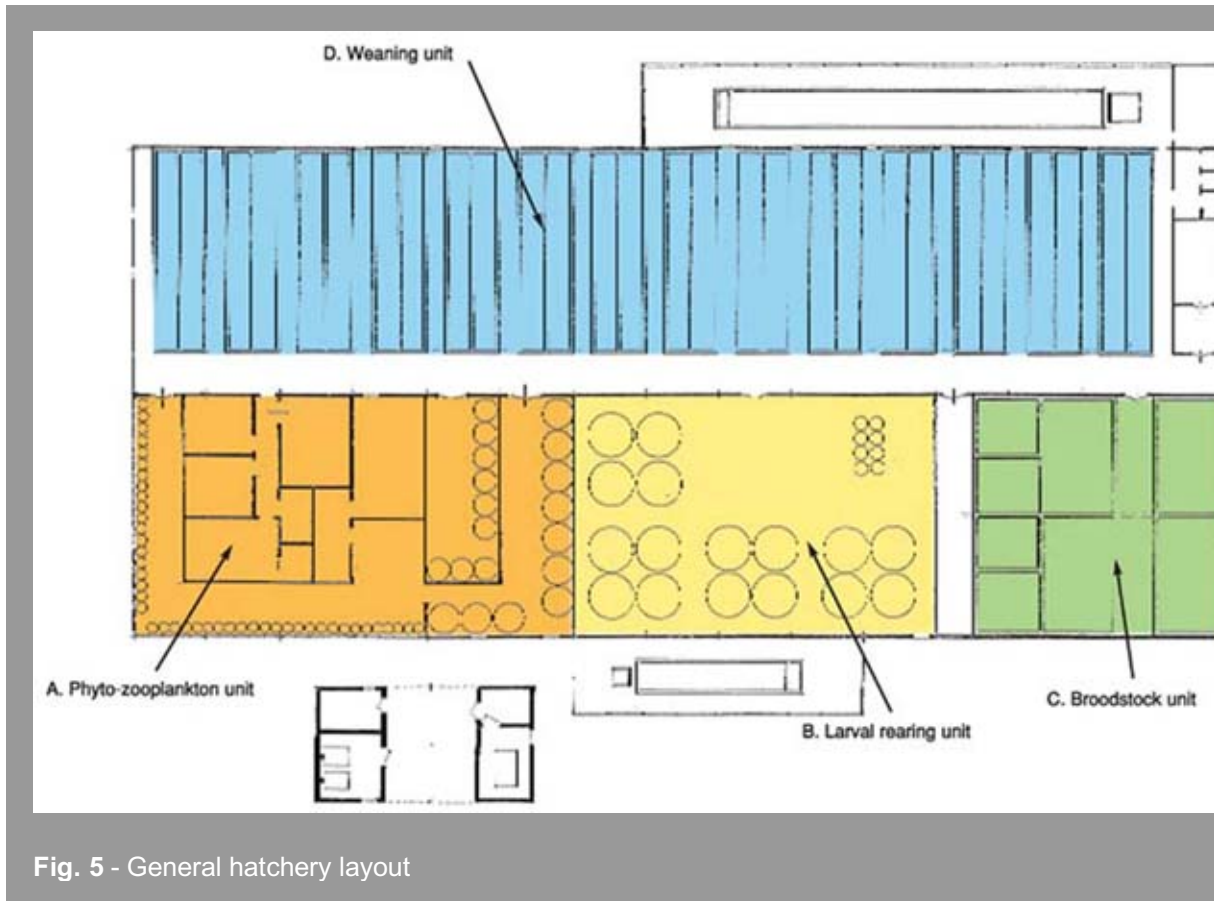

Fig. 5 - General hatchery layout

Different tank designs are used for different purposes. Before going into their description, it is necessary to know how to calculate the size of the facilities on the basis of the planned production.

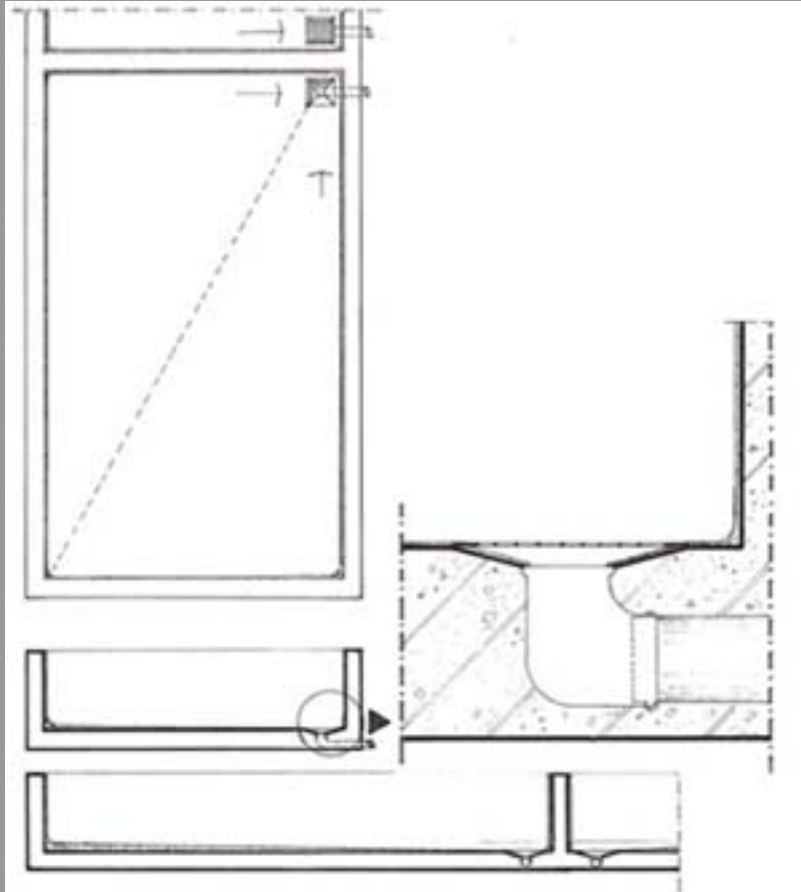

Fig. 6 - Concrete tank and PVC outlet

Calculating the size of the stocking facilities

The broodstock unit requires enough space to keep breeders in healthy conditions so that they can spawn viable eggs and can be used for more than one breeding season.

The total water volume **V** required for long term rearing of broodstock can be calculated by taking into account the following points:

- the total female body weight **fbw**, which in turn depends on the quantity of eggs needed (this figure can be calculated using the already described average female fecundity, that is 120 000 two-days old larvae per kg b.w. in case of seabass and 350 000 for gilthead seabream);
- the total male body weight **mbw**, which depends on the sex ratio (number of males, normally two per female) and the average individual size of the males;
- the larval survival rates for the different species to be reproduced;
- the stocking density **D** (expressed in kg/m³);
- the reproductive pattern (gonochoric or hermaphrodite);
- the number of spawns per year **S**, plus eventually a safety margin for the stock of 50%.

D should be 1 kg per m³ in large earthen ponds, and up to 5 kg per m³ in smaller plastic or concrete tanks.

The required water volume for species 1 (**V₁**) expressed in m³ is calculated as:

$$V_1 = [(fbw_1 + mbw_1) : D_1] \times S_1$$

The required total water volume **V** is calculated as the sum of **V₁ + V₂ + V₃...**, which depends on the number of reared species and adding the 50% safety factor.

This formula refers to the final standing stock of breeders, where all the required biomass is represented at its peak. When the volume includes also the out-of-season reproduction, it must be considered that it refers to the additional tanks placed indoors for control of temperature and photoperiod.

Example: calculation of the outdoor tank volume for a small multispecific hatchery with an annual requirement (one natural spawning season) of 4 million two-day old larvae of both seabass and gilthead seabream.

In seabass, considering the average female fecundity conservatively estimated above, we obtain:

$$4\,000\,000 : 120\,000 = 33 \text{ kg of females,}$$

which with an average individual weight of 1.25 kg corresponds to 27 females. With a sex ratio of 2:1 (males per female), the 54 males required with average weight of 0.8 kg per male add about 43 kg. Thus, the total biomass ($fbw_1 + mbw_1$) would be 76 kg (33+43) and it represents the minimal requirement of seabass spawners for one production season.

For gilthead seabream we have:

$$4\,000\,000 : 350\,000 = 11 \text{ kg of females,}$$

which with an average individual weight of 1 kg corresponds to 11 individuals. With the same sex ratio, the 22 males required, with average weight of 0.4 kg per male, add about 9 kg. Thus the total biomass ($fbw_1 + mbw_1$) would be 20 kg (11+9) and it represents the minimal requirement of gilthead seabream spawners for one production season.

To cover possible accidents, diseases and stock renewal, an extra 50% should be considered for safety reasons. Therefore, the total biomass of seabass would be around 114 kg, to which 30 kg of gilthead seabream breeders should be added.

With a long term stocking density of 1 kg per m³ in earthen ponds, 114 m³ would be required for seabass broodstock and 30 m³, for gilthead seabream, hence a total volume requirement of 144 m³.

Outdoor facilities

They are usually located close to the hatchery. The most common design being rectangular earthen ponds or round concrete tanks between 50 and 200 m³, but which can go up to 500 m³. This capacity is sufficient to hold a good number of fish, but at the same time allows an easy visual control of the captive broodstock and a proper water flow.



Fig. 7 - Outdoor tanks

The choice between earthen ponds and concrete tanks is often based on physical and chemical characteristics of the soil, as well as on local costs of construction, materials and labour.

When excavating earthen ponds, the following points should be considered:

- The water supply canal should fill the pond by gravity through a screened wooden or concrete-made inlet gate.
- The dyke slope (ratio of horizontal to vertical) of both ponds and canals depends on the type of soil used and the dyke elevation. With clay soils, dykes higher than 4 m should have a slope of 2:1, whereas for dykes lower than 4 m it should be 1:1. The internal side of the dyke that is moist all the time should have a gentler slope than the outer side, usually dry.
- Pond water depth should be 1.5 m on average, with a 2 to 5% bottom slope towards the drain to allow for an easy and complete drainage. The pond bottom should be properly levelled to prevent the formation of puddles when drained. Before starting the excavation, the possible presence of a high water table (fresh or sea water during high tide) should be checked, as a complete drainage of the pond may not be possible.
- The deeper area of the pond, on the side of the drain/outlet, should be lined with concrete or plastic liner to facilitate harvesting and cleaning operations.

- The external drainage canal should be deep enough to allow a complete drainage by gravity. A sufficient difference in level should exist between the bottom of the pond and that of the final water discharging point of the farm.

If concrete tanks are preferred, the same criteria concerning depth, water supply and drainage should be applied. The tank walls should be vertical to save space and material. The bottom slope should not exceed 1%. The construction of reinforced concrete structures in seawater requires a thicker cement layer around the steel bars to prevent corrosion.

When surface area is not a constraint, the separation between two adjacent tanks or ponds should be at least 4m to be used as road and to facilitate fishing and broodstock selection operations. If on a dyke, the road should have 0.6 m wide shoulders on both sides to prevent erosion. Canal crossings should be covered by steel grids, or by wooden or concrete slabs. Pipelines should be better placed in pre-fabricated concrete trenches, covered by a grid or concrete slabs required for periodic inspection.

A group of smaller tanks should be considered for quarantine of fish collected from the wild or bought for temporary stocking and for prophylactic or curative treatments. These tanks should be much smaller (4 to 6 m³) to reduce the use of drugs and chemicals during bath treatments. Fibreglass is frequently the preferred material due to its cost and manageability. The drainage design should allow treatment of the effluent prior to its final disposal to avoid the risk of contamination of the surrounding environment with pathogens and dangerous products.

During the hottest months, at least 10% of the pond area should be covered to give the fish some shaded areas and a place to rest. If necessary, protection against fish-eating birds should also be given.

Indoor facilities

The tanks where fish are temporarily stocked to obtain fertilised eggs are usually placed in a dedicated sector. They should be located in the quietest corner of the building to reduce disturbance to broodstock. An adjacent area should be reserved to clean, disinfect and store the equipment of the spawning unit.



Fig. 8 - Indoor tanks

Windows for this indoor section are not strictly necessary as spawning requires controlled light conditions, but they can be installed to renew the air and reduce humidity inside the spawning unit. Air extractors could be used in place of windows.

The floor of this unit should be tiled or painted with epoxy coatings to facilitate cleaning, and to maintain hygienic conditions. In order to drain the tanks an adequate drainage system made of screened channels under the floor is required. It should have a slope of at least 2%.

Thermal insulation of walls and roof is advisable in locations with cold winters to save on heating costs. A framework of zinc-coated steel beams suspended over the tanks should be considered to allow the installation of the main support systems such as heating, water supply and recirculation, light and electric systems, air and emergency oxygen supplies.

When considering a water recirculation system, enough floor space close to the tanks should be planned in the design stages to house its various components such as mechanical filters, biological filters, pumps, sterilizers, and heating devices. If the drains can be placed under the floor, the gutters going to the biological filters should be built well above the floor level to prevent dirt or toxic chemicals, such as disinfectants used to wash floors, from entering the recirculation system.

Spawning tanks

The spawning tanks are usually round or square (with rounded corners) tanks of 4-20 m³ capacity. They are made of concrete, FRP, or are PVC-lined. The complete control of environmental conditions allows a fish stocking density of up to 15 kg/m³, considerably higher than that used for long term stocking facilities. Spawning tanks are also utilised to obtain out-of-season spawnings.

Tank depth should be limited to 1.5 m as a maximum to facilitate the work of technicians. Even if automatic egg collectors are used, enough space should be left around the spawning tanks to allow for manual collection of eggs and broodstock manipulation.

In regions with low winter temperatures, the spawning tanks are filled with heated seawater, kept at temperatures between 14 and 18°C. To reduce fuel consumption, a semi-closed recirculation system is often adopted

Regardless of shape and size, the spawning tanks should fulfil the following conditions:

- easy control of the fish population;
- easy accessibility to the tank bottom for daily cleaning;
- simple and quick cleaning routine;
- easy replacement of the screened outlet;
- simple outlet construction for accessibility and service;
- minimum stress for fish at harvest;
- optimal swimming behaviour of fish;
- absence of transport problems in case of prefabricated tanks;
- optimal use of available covered area inside the building, which calls for square or rectangular, rather than round tanks;
- simple design of support systems (water supply/drainage, air supply, power supply, lights).

According to their shape, number and available space, tanks can be arranged in groups or in rows. In any case, staff should have easy access to at least 75% of their perimeter. The space between rows or groups should be wide enough (0.8 to 1.5 m) to permit the use of trolleys for working routines.

Water circuit

Spawners require ocean-quality seawater at a fairly constant temperature. In the absence of a reliable natural source of seawater at the right temperature, seawater has to be heated or cooled. When the breeding cycle is to be manipulated, a water recirculation system is introduced to reduce heating and cooling costs. This is also used in the coldest regions where the water temperature stays below 10°C for more than 3 or 4 months. Recycling systems require a biofilter where the toxic ammonia (the main harmful product of fish metabolism) is biologically oxidised into safer nitrites and nitrates.

PVC pipes are used to supply and drain water. The water circuit design should be planned as simply as possible with the minimum number of corners to avoid pressure losses and the appearance of dead circulation points where sediments and bacteria could accumulate. Its components should be assembled by means of fast joints and bolted flanges to facilitate dismantling for cleaning and service operations. According to the water supply system, i.e. by gravity or by pumping, PVC pipes should be NP6 or NP10 respectively to stand different water pressure levels. Each tank should be equipped with an independent inlet placed on the tank rim; a ball valve should be provided to adjust its flow according to requirements. Tap water should be easily at hand with a few delivery points and a washbasin for cleaning routines.

Lights

Light intensity should be maintained in the range of 500-1 000 lux at the water surface by means of a halogen lamp placed over each tank. Lamps should be controlled by a timer/dimmer switch giving a twilight effect when lights are turned on and off. Emergency lights that do not disturb fish could also be installed. Large windows should be avoided to prevent direct sunlight falling on the tanks.

Aeration system

Air supply is assured by a few coarse diffusers placed on the tank bottom and should be regulated to keep eggs suspended in the water mass. Plastic needle valves for aquarium or metal clamps (much more expensive) can be used to regulate air flow.

Overwintering facilities

In locations with mild winter conditions, breeders can remain in their long term stocking facilities all year round except at spawning time. Where climatic conditions are particularly severe, some precautions have to be adopted. In these cases fish holding facilities can be:

- protected by a light cover (a greenhouse for example),
- deepened (3 to 4 m),
- sheltered from the prevailing winds by means of windscreens,
- supplied with heated water.

These precautions, sometime expensive and difficult to put in practice, do not guarantee a completely safe situation in the colder locations. In that case, the whole broodstock must be moved into indoor facilities where the temperature can be kept at 10 to 12°C. At these temperatures fish have a reduced metabolism and therefore low feeding requirements resulting in limited production of organic wastes. Compared to outdoor facilities, a higher stocking density can be maintained (up to 15 kg/m³), thus reducing the space occupied by tanks.

Conditioning facilities

In many hatcheries indoor facilities are also used for conditioning breeders to delay or advance their natural sexual maturation cycle and spawning season. In that case, the conditioning/spawning areas become permanent facilities that occupy a dedicated part of the hatchery because of the long residence period needed. For practical purposes, such conditioning tanks are usually of the same design and material of the spawning tanks. Breeders are usually kept at a density of up to 15 kg/m³.

The area is also subdivided into several zones, isolated from each other, where different light/temperature regimes can be adopted. This requires independent systems for light and water temperature regulation. The heating system is often coupled with a cooling system, usually a heat pump, to provide out of season winter conditions.

1.8 LIVE FOOD UNIT

This unit is dedicated to the production of microalgae, rotifers and brine shrimp nauplii (*Artemia* sp.) in large quantities, to be used as live feed for fish larvae.

The unit has separate sub-units for:

- phytoplankton and rotifer pure strains and small volume cultures,
- phytoplankton and rotifer bag cultures,
- rotifer mass culture and enrichment,
- *Artemia* nauplii mass production and enrichment,
- laboratory tests.

Each sub-unit is housed in a room of variable size with tiled floor and walls and is provided with air conditioning, treated seawater supply, freshwater supply, air distribution system, working lights, safe plugs, and a drain system. Adaptations to the needs of each sub-unit are specified below.

The first three sub-units should be contiguous to simplify working routines, since they represent three different steps of the same production process. They should be placed close to the larval rearing unit to reduce transport distance. The laboratory services the entire unit, plus the other hatchery compartments. There should be, however, a pathology laboratory in a separate room, to prevent possible spread of diseases.

1.9 PURE STRAIN AND UP-SCALE CULTURE ROOM

Algae and rotifer pure strains, as well as up-scale cultures (from small vessels up to 5-10 litre flasks/carboys), should be kept in an air-conditioned room under sterile conditions to avoid possible contamination. Floor and walls in this room should be tiled for easy washing and disinfection. A small drain system is all that is required since all culture vessels are kept sealed or are drained through the washbasin outlet. An adjacent room of smaller size, with the same hygienic precautions, is reserved for culture duplication and storage of consumables.

The cultures, whether in test tubes or glass or plastic vessels, are placed on shelves with lights and are kept at a temperature range of 14-16°C. A CO₂-enriched air supply system connected to the culture vessels provides an additional source of carbon and ensures the necessary turbulence. An ideal solution for pure strains is a lighted incubator where all test tubes are stocked under optimal conditions.

As all culture volumes are sterilized and prepared in advance, this room is the only part of the live food unit without a supply of treated seawater. All glassware, water medium and nutrient solutions are sterilized before use, following the procedures explained in Volume 1 of this manual. The equipment for sterilization varies according to the system chosen (see part 3 for details), and is typically housed in the laboratory or in an adjacent service room. A germicidal lamp (UV light) should be installed to control the residual bacterial contamination in the air. Note that this UV lamp must be switched on only when no staff are inside the rooms, and therefore, security switches should be installed on the door.

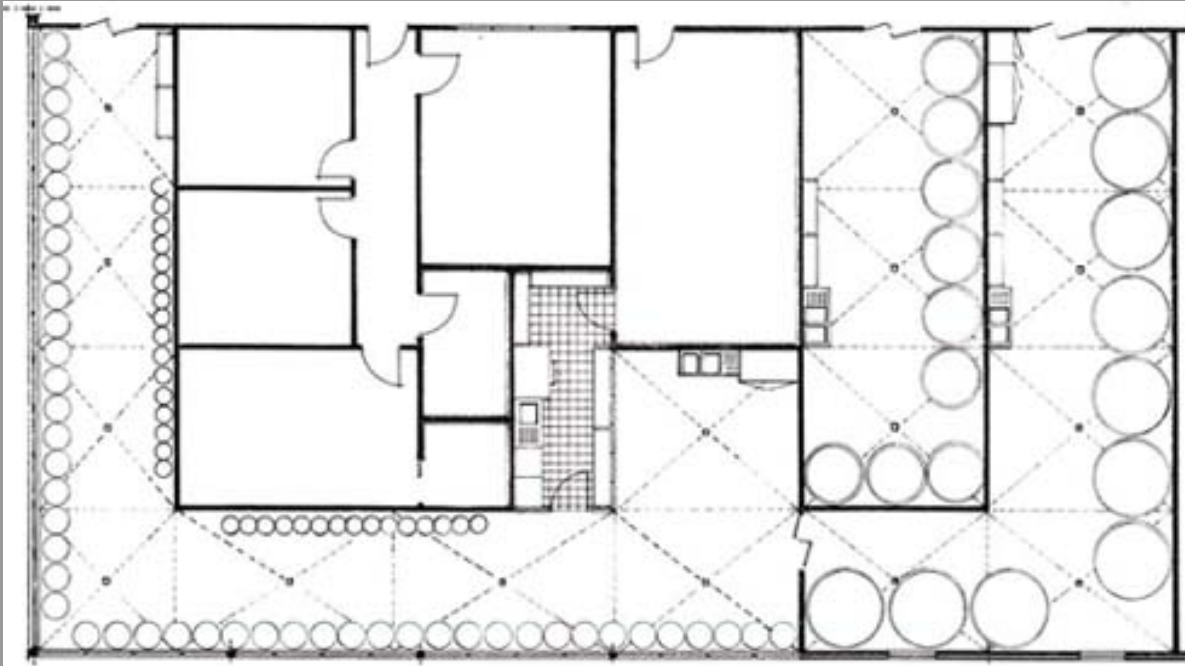

Fig. 9 - Plan of phyto and zooplankton unit and pure strain room



Fig. 10 - Plan of offices and services in phyto/zooplankton section

Support systems

Light is extremely important in algal culture. The right-size fluorescent tubes are conveniently placed to provide a light intensity of up to 1 000 lux for pure strains and up to 6 000 lux for larger vessels. They are placed horizontally under the glass shelves as well as on the sides of the shelves and are protected from water splashes by means of waterproof plugs.

Aeration is required to create turbulence and to provide oxygen for both algae and rotifer cultures. Each vessel, with the exception of test tubes, is equipped with one glass tube connected to the air pipe by a flexible plastic hose. The air is distributed through a central PVC pipe with branches going to each shelf.

To accelerate algal growth, carbon dioxide is added to the air blown into the vessels at a volume rate of 2%. Commercial grade CO₂ bottles are connected to the main pipe through a gauge and flowmeter. To monitor its flow, a bubbling flask is installed before the connection to the main air pipe. As carbon dioxide is heavier than air, some U-shaped joints are installed along this pipe to prevent stratification.

Due to the heating effect of the lights installed in the room, air conditioning is usually necessary to keep the temperature within an optimal range. The air conditioning should also work inside the replication room due to the prolonged use of Bunsen burners while preparing glassware for culture replication.

Tap water should be available and a washbasin for cleaning routines. Only the personnel in charge of this sub-unit should enter this room and they should dip their boots in a tray filled with disinfectant solution.

Equipment

The equipment in this sub-unit is mainly glassware for culture duplication and monitoring of algal cultures. Sterilized vessels of different capacity, filled with seawater, should always be available for duplication and up scaling. A cupboard is useful to store all sterilized material before use. Consumable equipment (chemicals to prepare nutrient solutions, glass tubes, etc.) should also be stored in this subunit. One plastic basin filled with 10% hydrochloric acid solution is required to disinfect pipettes after use. Used glassware is washed, filled and sterilized in the laboratory or in another dedicated room.

1.10 INTERMEDIATE ALGAE AND ROTIFER BAG CULTURE ROOM

In this sub-unit, algae and rotifers are cultured in large quantities in polyethylene (PE) bags. They are used directly to feed fish tanks (algae), or as inoculum for duplication and for larger volumes (algae and rotifers). The bags are housed in a dedicated room adjacent to the sub-unit described above. The floor of this room should be tiled to facilitate cleaning procedures and should have a slope of at least 2% towards drains.

Bags and stands

Two basic designs of PE bags of different capacities are utilised: a smaller single or double suspended bag (capacity 50 to 150l), and a larger one standing inside a wire mesh cylinder (up to 400l). In both cases, hot extruded tubular PE of 0.2 to 0.3 mm thickness is employed. This is a cheap, disposable material that can be shaped according to production needs. The bottom of the bag is sealed either by hot welding, or in the case of the U-shaped double bags just by knotting. The largest bags are placed inside a wire mesh cylinder placed on a fibreglass or wooden base that has a V-shaped central cut. This V-shaped cut allows proper placement of the bottom of the bag.

Suspended bags hang from stands located either in the centre of the room or along the walls. The second solution is preferred when transparent walls are used, to take advantage of sunlight. Stands are preferably made of zinc-coated steel to prevent corrosion. For the same reason, wire mesh should be plastic-coated.

Whenever possible, the design should include large windows or glass walls.



Fig. 11 - Stands for large PE bags

Support systems

This sub-unit is connected to the heated seawater distribution system through some taps. Bags are filled using flexible hoses which can be disconnected, emptied and placed in a basin with hypochlorite solution for disinfection.

Due to the heat produced by the artificial lighting system, air conditioning may sometimes be necessary to keep temperatures within optimal ranges (18-22°C). Air temperature control is required for the hatcheries working with gilthead seabream in order to supply the large amounts of algae required for this species. In addition, it may be necessary to cool the air in the hottest months in order to maintain the algal growth within its optimal conditions.

Fluorescent tubes provide the necessary illumination. They should be placed to provide an intensity of 6 000 lux (range: 4 000 - 8 000) over the entire bag surface. They can be arranged either horizontally or vertically, but in both cases, they must be protected from water splashes by means of sealed plastic cases or waterproof plugs. Allow at least one 36 W tube per small bag, and two for larger ones. To save energy, between four and ten tubes should be grouped and connected to a single switch. Glass walls can save energy during the day. A light sensor (photocell) can turn the lights on and off. Then large windows should be installed as this will turn this room into a greenhouse, reaching very high temperatures during spring and summer.

Aeration is required to assure proper turbulence in the bags and each bag is equipped with two air hoses (best to use tubing of 6 mm inner diameter) placed near, but not on the bottom, to avoid stirring the sediment. As the water weight keeps the PE film well stretched, air hoses can be put in place by simply forcing them through a very small hole in the desired place. The air distribution system is built with a central PVC pipe with branches going to each bag row.

Tap water should be easily available with a few delivery points and a wash-basin should be provided for cleaning routines.

Besides illumination, the electric system should be designed with a few waterproof sockets, which could be used to connect plastic pumps for harvesting, transfer and inoculum operations. All material such as switches, plugs or sockets used in the electricity network should be waterproof, with each socket controlled by a safety switch on the sub-unit control panel.



Fig. 12 - Aeration tube in PE bag

Equipment

The equipment in this sub-unit includes plastic containers to produce algae and rotifers (buckets, funnels, graduated cylinders, containers with a cap for chemicals and nutrients, etc.) and the glassware to monitor the algal and rotifer cultures (pipettes, Petri dishes, microscope slides, etc.). Bags are filled by means of flexible hoses connected to the seawater supply points.

Whereas all rotifer cultures are filtered before their re-utilization, mature algal cultures are directly transferred by means of self-priming submersible plastic pumps, whose hoses have to be carefully washed and disinfected after use.

A couple of large, flat tanks (with a capacity of about 1 000l) filled with disinfecting solution (500 ppm hypochlorite or 10% hydrochloric acid) is used to disinfect all tools after use.

Space requirement calculations

The space occupied by bags can be calculated by assessing the planned daily peak consumption of algae and rotifer cultures for up-scaling. Such calculations should therefore take into account:

- the peak daily amount of rotifers to be used as inoculum for new mass culture tanks;
- the peak daily amount of rotifers to be re-used to inoculate new bags;
- the peak daily amount of algae requirements for rotifer duplication;
- the peak daily amount of algae requirements for green water in the larval rearing unit;
- the peak daily amount of algae to be re-utilized as inoculum for new bags;
- the average number of days required to obtain a mature culture of phyto or zooplankton.

1.11 ROTIFER CULTURE AND ENRICHMENT

In this sub-unit rotifers are cultured in large quantities in tanks of larger capacity than the bags previously described, and are then enriched before being fed to fish larvae. This production is carried out in a specific room, usually adjacent to the bag culture sub-unit to facilitate the transfer of cultures from one room to the other. Floor and walls should be covered with tiles for hygienic reasons. As harvesting takes place in the same room, involving large quantities of culture water, an efficient drainage system is required.

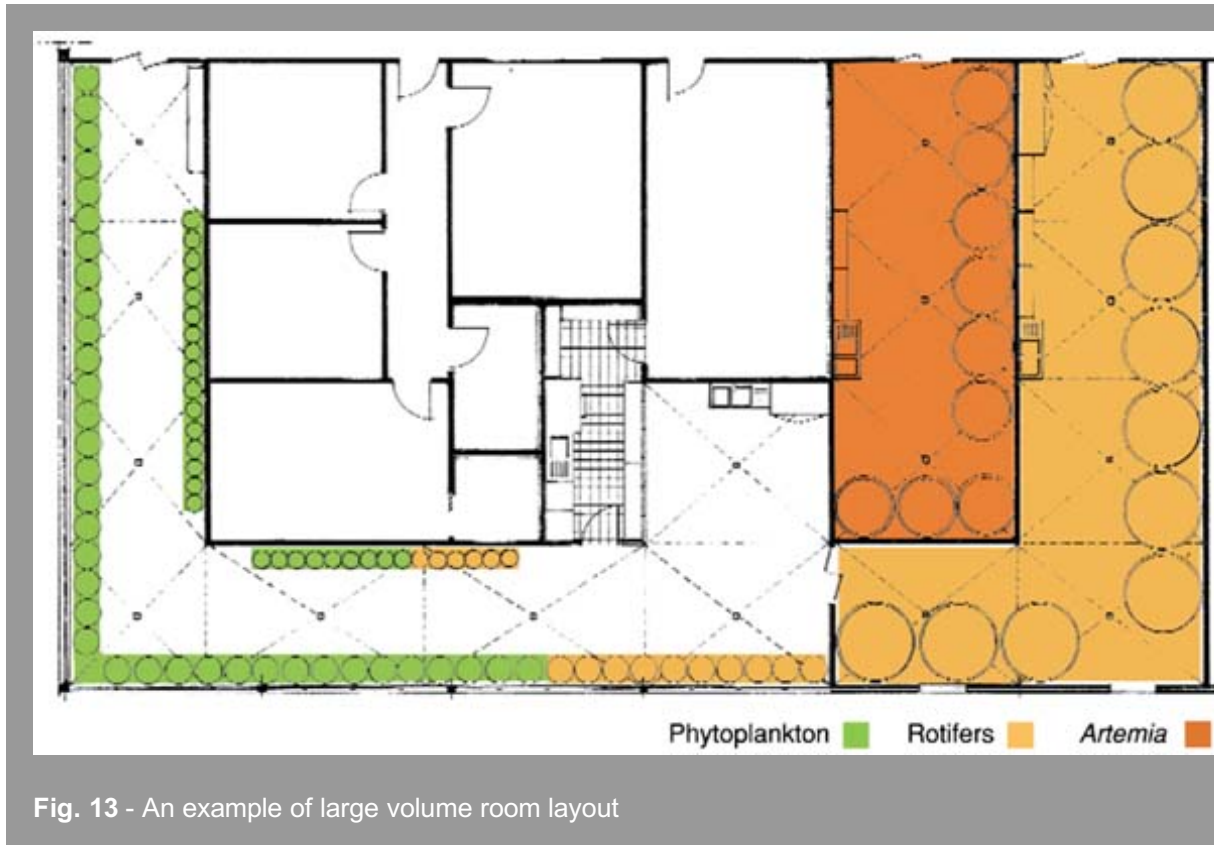

Fig. 13 - An example of large volume room layout

Production facilities

Optimal rearing tanks are round tanks with a conical bottom with a capacity ranging between 1 and 4 m³. Their inner surface can be white gel-coated to improve cleaning. An adequate drain with a valve at the cone tip is needed for harvesting operations.

As their management requires frequent observations (water quality monitoring, feeding, enrichment and cleaning), these tanks are usually placed in double rows separated by a wooden or metal walkway.

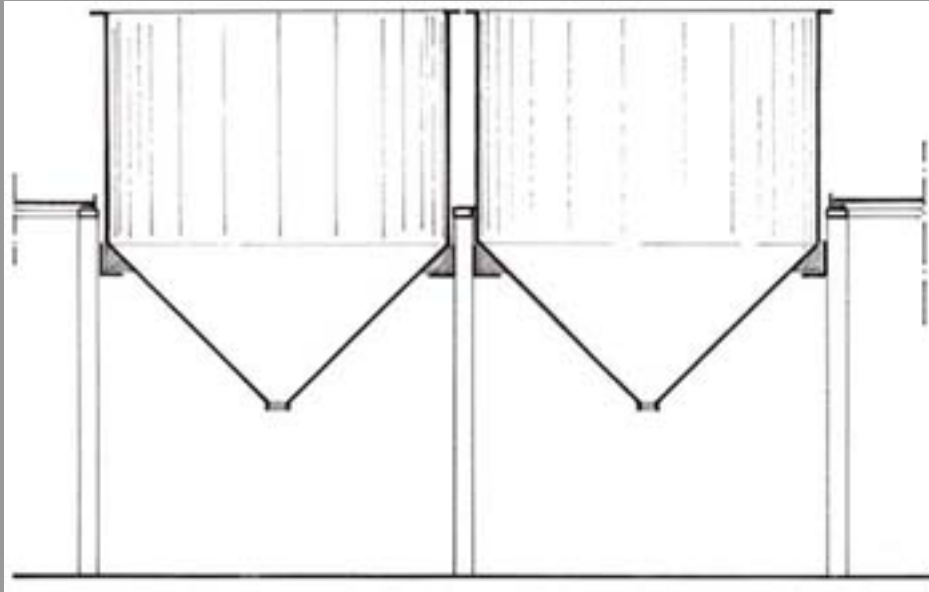

Fig. 14 - Rotifer tanks

Support systems

The mass production of rotifers takes place at higher temperatures than that of algae (typical temperature is $>25^{\circ}\text{C}$). A heated seawater circuit is therefore necessary. This circuit must be provided with a control to adjust the temperature in a very short time (see below for technical details). Because these cultures are static, the temperature in the tanks is maintained with electrical heaters made of titanium or with coiled tubing all around the tank. Due to the water masses involved, an air heater is usually not necessary.

As algae are being replaced by artificial diets, only service lights are required.

Aeration is required to maintain adequate levels of turbulence in the tanks, and each tank is fitted with air stones placed at about 15 cm from the bottom to avoid stirring the sediment. At least 5 air diffusers are used in a 2 m^3 tank: one at the centre, and the other four placed along the wall. Around $2\text{-}3\text{ m}^3/\text{h}$ of air flow per m^3 of culture volume is required.

Tap water should be at hand with a few delivery points and a wash basin.

The electricity system should be designed with a few waterproof sockets to connect plastic pumps for harvesting, transfer and inoculation operations. As in the other sub-units, all the material used in the electricity system should be waterproof, with each socket controlled by a safety switch on the sub-unit control panel.

Equipment

The equipment in this sub-unit should include an array of plastic containers for routine works (buckets, funnels, graduated cylinders, beakers, etc.), as well as large containers to keep the chemicals, the glassware for culture monitoring (pipettes, Petri dishes, microscope slides, etc.) and thermometers for routine checks. Flexible hoses with fast PVC joints connect the bottom valves to the filter used during harvesting. Trolleys with a flat platform are useful to transport the various containers and other equipment used in this sub-unit. Large plastic filters with a 60 mm mesh are used to harvest rotifers.

Space requirement calculation

The space occupied by this sub-unit is determined by the expected maximum daily consumption of rotifers by the larval fish unit. The calculation should therefore take into account:

- the peak daily amount of rotifers to be fed to fish larvae,
- the peak daily amount of rotifers to be re-used to inoculate new tanks,
- the individual volume and number of the rotifer mass culture tanks,
- the average density of enriched rotifer at harvest,
- the average number of days to get a mature rotifer culture.

The first point depends on the total number and age of fish larvae being reared in the larval unit and their feeding requirements, whose estimation is included in Volume 1, annexes 17 and 18, for both seabass and gilthead seabream.

The second point is a function of the mass culture system adopted: to speed up production, enriched rotifers in their log phase can be successfully utilized as inocula to start new tank cultures.

The third point is a function of the average daily consumption, adjusted to cover reduced needs during the initial and final rearing periods and adding a safety margin to take into account possible losses and culture crashes.

The fourth point depends on the rearing conditions, rotifer batches and management. A conservative output of 600 - 900 million enriched rotifers per m³ should be considered.

1.12 BRINE SHRIMP PRODUCTION AND ENRICHMENT

The production of brine shrimp (*Artemia*) larval stages (nauplii and metanauplii) is carried out in a separate room, usually adjacent to the rotifer sub-unit for practical reasons (same treated seawater supply, air conditioning system and staff). The design should not include windows or transparent walls, as harvest of *Artemia* nauplii requires conditions of total darkness. As in the other units, the floor and walls should be tiled to help maintain good hygienic conditions. As harvesting takes place in the same room with tons of culture water being filtered daily, an adequate drainage system is necessary (a central manhole or screened channel drains).

Production facilities

Different tank designs have been adopted for brine shrimp incubation and enrichment. However, the basic round tank with conical bottom offers near ideal conditions in respect of water circulation, aeration and harvesting. Tank capacity can be usually lower (1 to 2 m³) than that of tanks for mass culture of rotifers, to give greater production flexibility.

The tank inner surface can be painted in white (gel-coated) to ensure a better light diffusion (important in the first hours of cyst incubation) and proper cleaning. The tanks must have a transparent window near the cone tip to attract nauplii at harvest time by means of a light source. A drain with a valve at the cone tip is used for harvesting.

Due to the limited routine work (what is required is mainly DO monitoring and enrichment diet supply every 12 hours), these tanks should be positioned along the walls to leave enough free space at the centre of the room for harvesting operations.

Support systems

The production of *Artemia* nauplii requires high temperatures (27-30°C) for optimal hatching rate and high hatching efficiency. Therefore, only heated seawater from the same circuit that serves the rotifer and algal sub-units is utilised. The heating system should be able to heat water to the optimal

temperature in a very short time (see below for technical details). To prevent heat dispersion in the room and cooling of the tanks, an air heater should be installed to maintain room temperature at a nearly constant level.

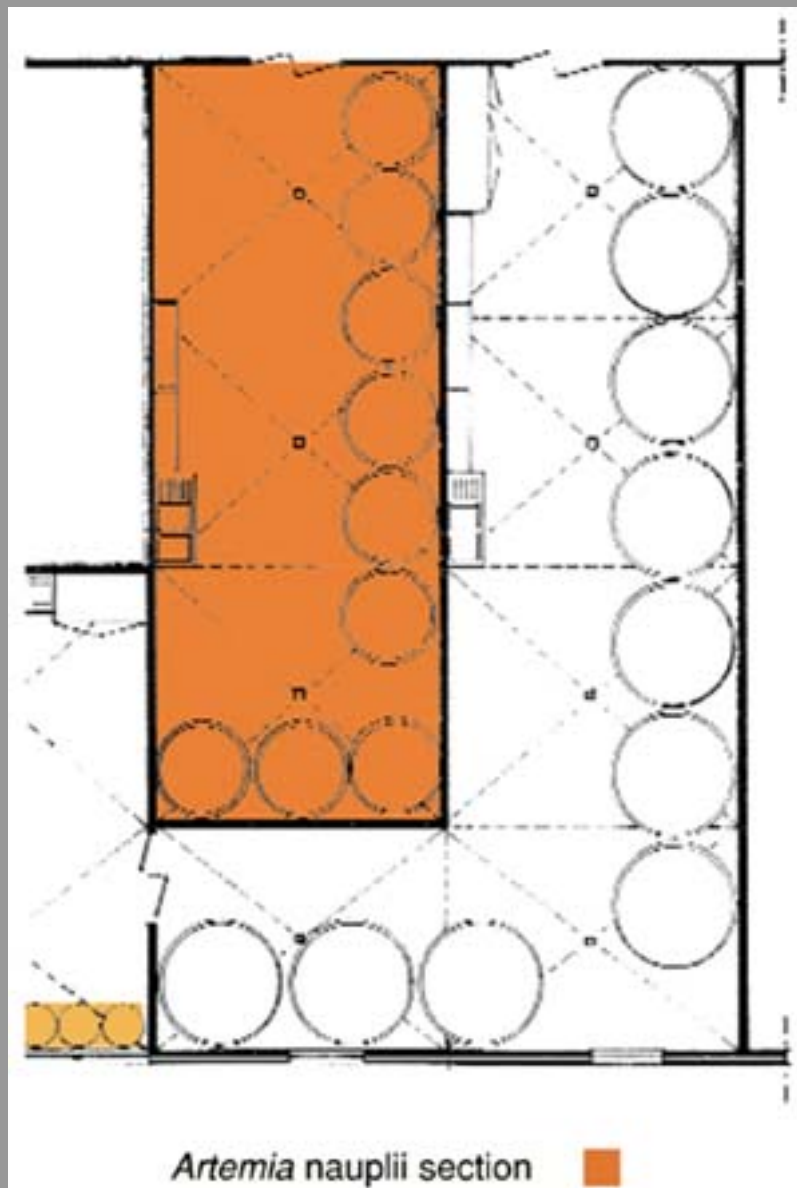

Fig. 15 - *Artemia nauplii* section

The best output is obtained under strong light and aeration conditions. A lamp should therefore be installed in each tank. It should be made with 1 or 2 fluorescent tubes delivering 2 000 lux at the water surface. A sealed plastic container or waterproof plugs are recommended since the strong air bubbling in the tanks produces a vaporized salt water spray.

To provide the strong aeration needed, an open-ended PVC pipe ($\frac{3}{4}$ " \varnothing) is placed in each tank near the bottom. A ball valve allows regulation of the air flow, which should be about 6-8 m³/h per m³ of incubation volume.

Tap water should be at hand with a few delivery points and a wash-basin for cleaning implements. The electricity system should be designed with a waterproof plug near each tank to install either a

submersible electric heater or the harvesting light. As usual, the electricity system should be waterproof, with each socket controlled by a safety switch on the sub-unit control panel.

Equipment

When large amount of cysts have to be handled, it may be practical to add a separate area equipped with several smaller round-conical tanks (50 to 100l) for cyst disinfection or decapsulation. This area differs from the main *Artemia* room in that an efficient system for air renewal/extraction is needed. This is because toxic reagents that produce gases are used in the process of decapsulation.

The equipment in this sub-unit should also include plastic containers of different sizes for routine work (buckets, funnels, graduated cylinders, beakers, etc.), as well as large containers for the chemicals used in the disinfection/decapsulation process, the glassware used for culture monitoring (pipettes, Petri dishes, microscope slides, etc.) and thermometers. Flexible hoses with fast PVC joints are used to connect the bottom valves to the filter utilized for harvesting. Trolleys with a flat platform are useful to transport equipment.

The design of the filters to harvest brine shrimp nauplii and metanauplii is similar to that used to harvest rotifers although a larger mesh size of 125 mm for nauplii and 200 mm for enriched metanauplii is used.

In addition, this sub-unit requires enough space in the cold storeroom of the hatchery to keep *Artemia* cysts and enrichment diets in proper conditions before their utilisation.

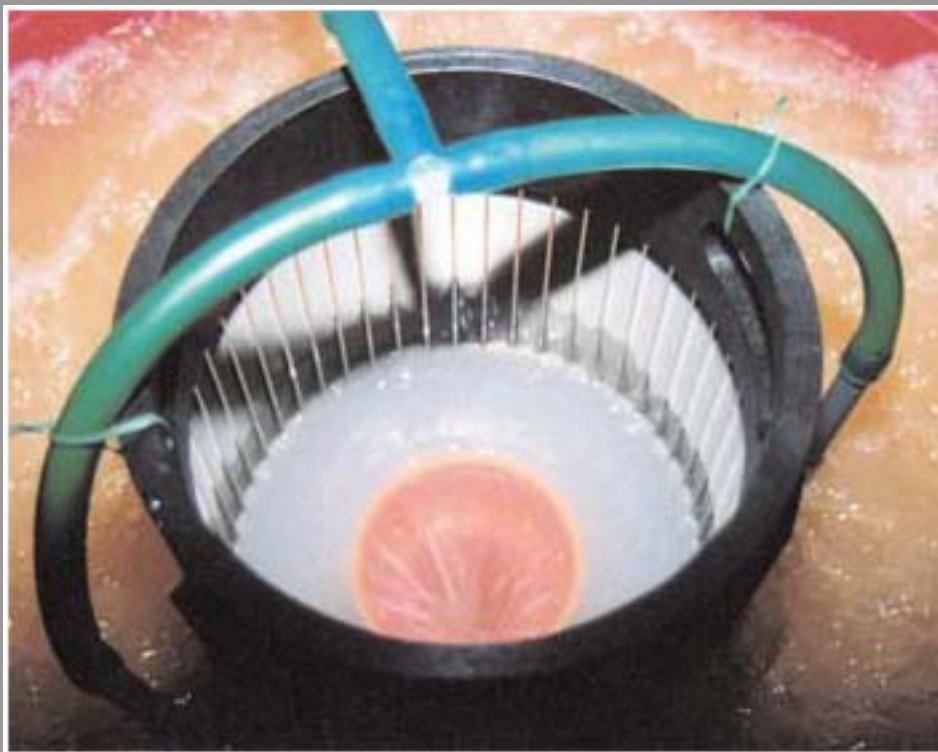

Fig. 16 - Filter for *Artemia* decapsulation, or for rinsing and enrichment after harvesting

Space requirement calculation

The space occupied by the *Artemia* culture tanks is determined by the expected daily maximum consumption of brine shrimps nauplii (first larval fish feeding) and enriched metanauplii. Calculations should therefore consider:

- the peak daily amount of nauplii and enriched metanauplii consumed by fish,

- the volume of the *Artemia* tanks,
- the average output density of nauplii and enriched metanauplii,
- the number of tanks for incubation (T_i),
- the number of tanks for enrichment process (T_e),
- the timing of both operations (24 hours incubation, 12 or 24 hours for enrichment).

The first point depends on the total number and age of fish larvae being reared in the larval unit and their feeding requirements.

The second point is a function of the average daily consumption and the necessary flexibility to cover reduced needs during the initial and final rearing periods.

The third point depends on the quality of *Artemia* batches: with an incubation density of 2.5 g/l, a conservative estimate would be an output of 450 000 nauplii/l for low quality cysts (to be enriched as metanauplii) and 650 000 nauplii/l for high quality cysts. The stocking density for nauplii enrichment is 300 000 nauplii/l, and the minimum survival expected after 24 hours is 90%.

Warning: batches may vary widely in terms of efficiency, hatching time and hatching rate.

Example: If the peak demand per day is one billion enriched metanauplii, we need to stock 1.1 billion nauplii (with an estimated survival rate of 90%). If we use cysts with an average output of 220 000 nauplii per g of cyst incubated, the amount of cysts to be incubated would be 5 kg. Using an incubation rate of 2.5 g per litre a volume of 2 000 litres is required, that may be provided by a single 2 000l tank, or two 1 000l tanks. Twenty four hours later, a further 3 700 litres of tank volume would be required to enrich the nauplii (at an initial density of 300 000 nauplii/l), which means 2 tanks with a capacity of 2 000l each.

1.13 LARVAL REARING UNIT

The rearing of the fish larval stages takes place in a large room, usually located not far from the live feed production unit to facilitate the transport of algae, rotifers and brine shrimp nauplii. The same room should have enough space to house the following ancillary facilities:

- the tanks where eggs are incubated,
- an area where all the equipment required in this room could be routinely cleaned, disinfected and stored,
- the insulated tanks for the cold storage of live feed (enriched rotifers, brine shrimp nauplii and enriched metanauplii).

Windows are not necessary as larval rearing requires controlled light conditions, but they can be installed to renew the air inside the room and to reduce humidity. Fan extractors can be used as well. Floor and walls should be tiled to secure proper hygienic conditions and to facilitate frequent cleaning. Since at harvest the tanks are emptied, an adequate drainage system is required. It should be made with screened channels under the floor, which should have a slope of at least 2%.



Fig. 17 - Larval rearing unit

Thermal insulation of walls and roof is advisable in locations with cold winter conditions to save on heating costs.

A framework of zinc-coated steel beams suspended over the tanks is the cheapest solution to support all service systems (heating, water supply and recirculation, light and electric system, air and oxygen supply).

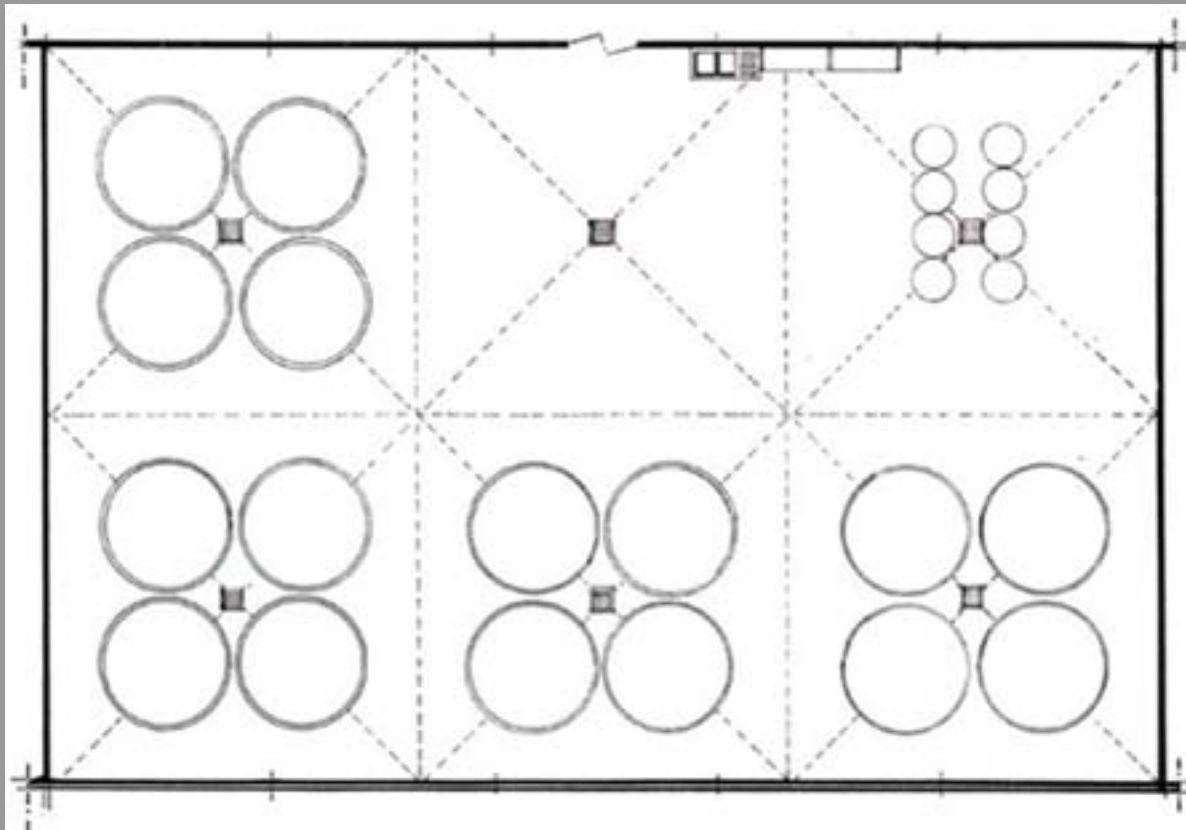

Fig. 18 An example of larval rearing room layout

When a water recirculation system is used, enough floor space close to the larval rearing tanks should be planned to place components such as mechanical and biological filters, pumps, sterilizers and heating/cooling devices. If normal drains can be placed under the floor, it should be borne in mind that this cannot be done for the gutters conveying water to the biological filter. These gutters should be placed above floor level to prevent dirt or toxic chemicals, such as disinfectants used to wash the floor, from entering into the recirculation system.

Production facilities

Egg incubation can take place either in the larval rearing tanks or in tanks designed for this purpose, usually round tanks with conical bottom due to of their near optimal water circulation. Their capacity ranges between 100 and 500l since a small volume allows for a higher water exchange rate and makes the harvest of newly hatched larvae easier. As egg incubation lasts a few days only, the tanks can be used for several hatching cycles. Materials used are fibreglass or plastic ensuring a smooth inner side to avoid damage to eggs and larvae. Due to the relatively small amounts of water required, the water supply system for these tanks is preferably of the flow-through type, i.e. new water is added continuously and not recirculated.

For the larval rearing of Mediterranean fish, different tank designs have been adopted: high round tanks with conical bottom, low circular tanks with a slightly concave bottom or flat-bottomed square tanks. On average their capacity ranges from 2 to 12 m³. They are most commonly made of fibreglass, but reinforced concrete, PE and PVC are also used.

The shape and size of larval tanks are decided on the basis of a number of considerations:

1. *management efficiency:*

- the larval population should be easily visible throughout the whole water volume;
- the tank bottom should be easily accessible for daily cleaning; a white colour facilitates a better detection of dirt;
- cleaning should be a simple and not time-consuming routine;
- the feed should be evenly distributed;
- the round tank walls can be painted in black to facilitate food particles detection by fish larvae;
- easy replacement of screened outlets;
- simple outlet construction for access and service;
- minimum stress to fish at harvest;

2. *water circulation:*

- absence of dead zones and related negative consequences (anoxia, ammonia build-up, etc.);
- optimization of the aeration pattern;
- concentration of settled wastes in a few areas of the tank bottom to allow for a faster and more efficient cleaning;
- optimal swimming behaviour of fish;
- optimal distribution of food particles;

3. *economics:*

- low cost and local availability of building material;
- transport problems in case of prefabricated tanks;
- optimal use of space;
- simplified design of support systems (water circulation, air supply, power supply, illumination);
- manpower requirements for their management;

4. *risk prevention:*

- a large number of smaller tanks offers a better protection against disease outbreaks than just a few large tanks.

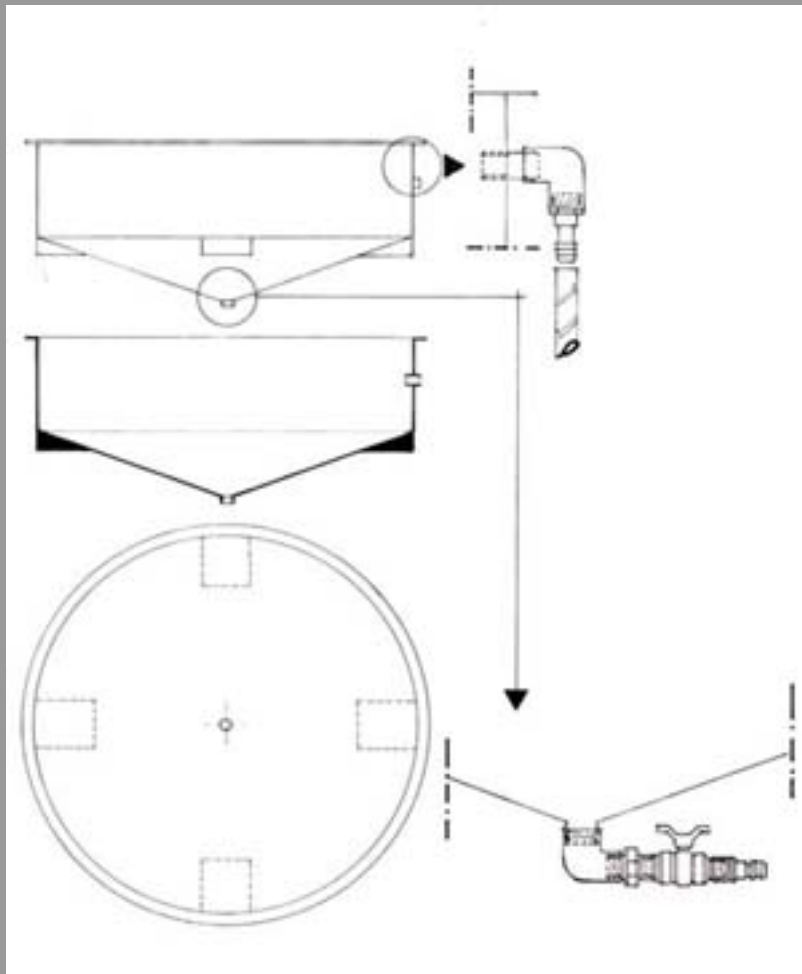

Fig. 19 - Fibreglass tank

Among Mediterranean hatcheries, small tanks with a conical bottom are being progressively replaced by larger flat tanks (5 to 10 m³) as they simplify considerably the overall design of the larval unit and reduce staff labour. On the other hand, the use of large tanks may imply a higher risk in case of disease outbreaks.

According to their shape, number and available space, tanks are arranged either in groups or in single or double rows. In either case, staff should have access to at least 75% of their perimeter. The space between rows or groups should be wide enough (0.8 to 1.5 m) to permit the use of trolleys for live feed distribution.

Support systems

As a rule, the larval rearing unit requires ocean-quality seawater at a fairly constant temperature, in the range of 16 to 20°C. In the wild, reproduction of seabass and gilthead seabream takes place during the cold season, with lower seawater temperatures but larval growth is also slower. If a reliable natural source of warm seawater is available or when the difference in temperature with the external environment is acceptable, the larval sector is equipped with a flow-through circuit, i.e. the water that enters the tanks is not recycled at the outlet, but discharged.

Seabass and gilthead seabream water parameters	
Temperature	18 - 22 °C
Salinity	25 - 35 ppt
Oxygen	100% sat.
pH	7,8 - 8,1
Unionised Ammonia	< 0,020 mg/l
Copper	< 0,0010 mg/l
Lead	< 0,004 mg/l
Iron	< 1 mg/l
Nickel	< 0,010 mg/l
Zinc	< 0,050 mg/l
Cadmium	< 0,003 mg/l
Chlorine	< 0,020 mg/l
Chromium	< 0,050 mg/l

Fig. 20 - Water quality. Rearing parameters

In the other cases, cold raw seawater has to be heated. To reduce the heating costs, recirculation systems are included, in which most of the rearing water is recycled instead of being replaced by new water. Recycling systems require a biofilter where toxic ammonia (product of fish metabolism) is biologically oxidised into the safer nitrites and nitrates. PVC pipes are utilised for water supply and drainage. The circuit design should avoid sharp bends and be as simple as possible to avoid large pressure losses and the establishment of dead zones where sediments and bacteria could accumulate. Components should be assembled by means of fast joints and bolted flanges to allow easy dismantling for cleaning and service operations. According to the water supply system, i.e. by gravity or by pumping, PVC pipes should be NP6 or NP10 respectively to stand different pressure levels.

Each tank should be equipped with an independent inlet placed on the tank rim; a ball valve should be used to adjust its flow according the larval rearing requirements. The angle at which water enters the tank will depend on tank design and on the age of the fish population.

Light intensity should be maintained in the range of 800-3 000 lux at the water surface when both gilthead seabream and seabass are reared. A halogen lamp placed over each tank works well and has a low electricity consumption. As a general rule, 20W for every 1.5 m² of water surface should be sufficient. Lamps should be controlled by a timer/dimmer switch to produce a twilight effect and to reduce stress when lights are turned on and off.

A service light that would not disturb fish may also be useful in case of emergencies. Large windows should be avoided to prevent direct sunlight from reaching the larval rearing tanks, as it is a source of great stress for fish larvae.

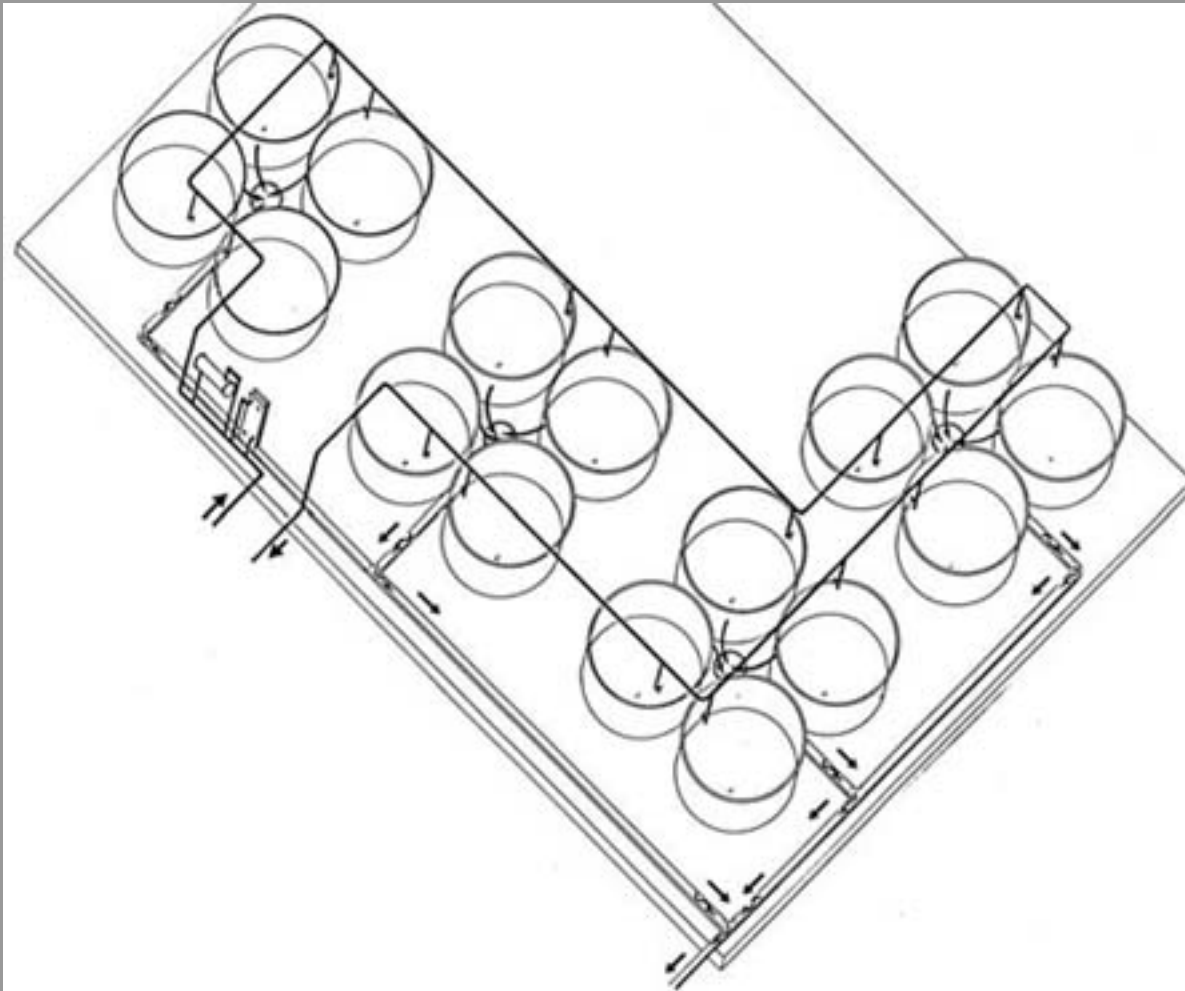

Fig. 21 - Three-dimensional sketch of a larval rearing unit with open flow circuits

To prevent excessive turbulence, the aeration in fish larval rearing tanks should be very gentle, with an air flow of up to 60l/minute. Aeration is assured by means of one or more fine diffusers placed on the tank bottom. The aeration, in synergy with water circulation and tank shape, should provide an even distribution of oxygen and food particles as well as gentle currents to allow fish larvae to develop their swimming behaviour. Aquarium plastic needle valves, or metal clamps (much more expensive), can be used for air flow regulation. Tap water should be at hand with a few delivery points and a wash-basin for cleaning purposes.

Space requirements

Incubation tanks

The water volume required to incubate eggs is based on the following criteria, which are valid for both fish species:

- maximum density of fish eggs: 15 000/l,
- minimum acceptable rate of viable larvae: 75%,
- number of viable larvae at the start of each larval cycle (see below),
- unit volume of incubation tanks.

Larval rearing tanks

The water volume necessary for larval rearing is determined on the basis of the following criteria:

- number of fish species to be reared,
- amount of fingerlings required per species and production cycle,
- final larval density and average survival in the larval rearing sector,
- final larval density and average survival in the weaning sector.

The last two points also depend on a number of variables such as: tank shape, rearing method, staff experience, availability of viable eggs and so on.

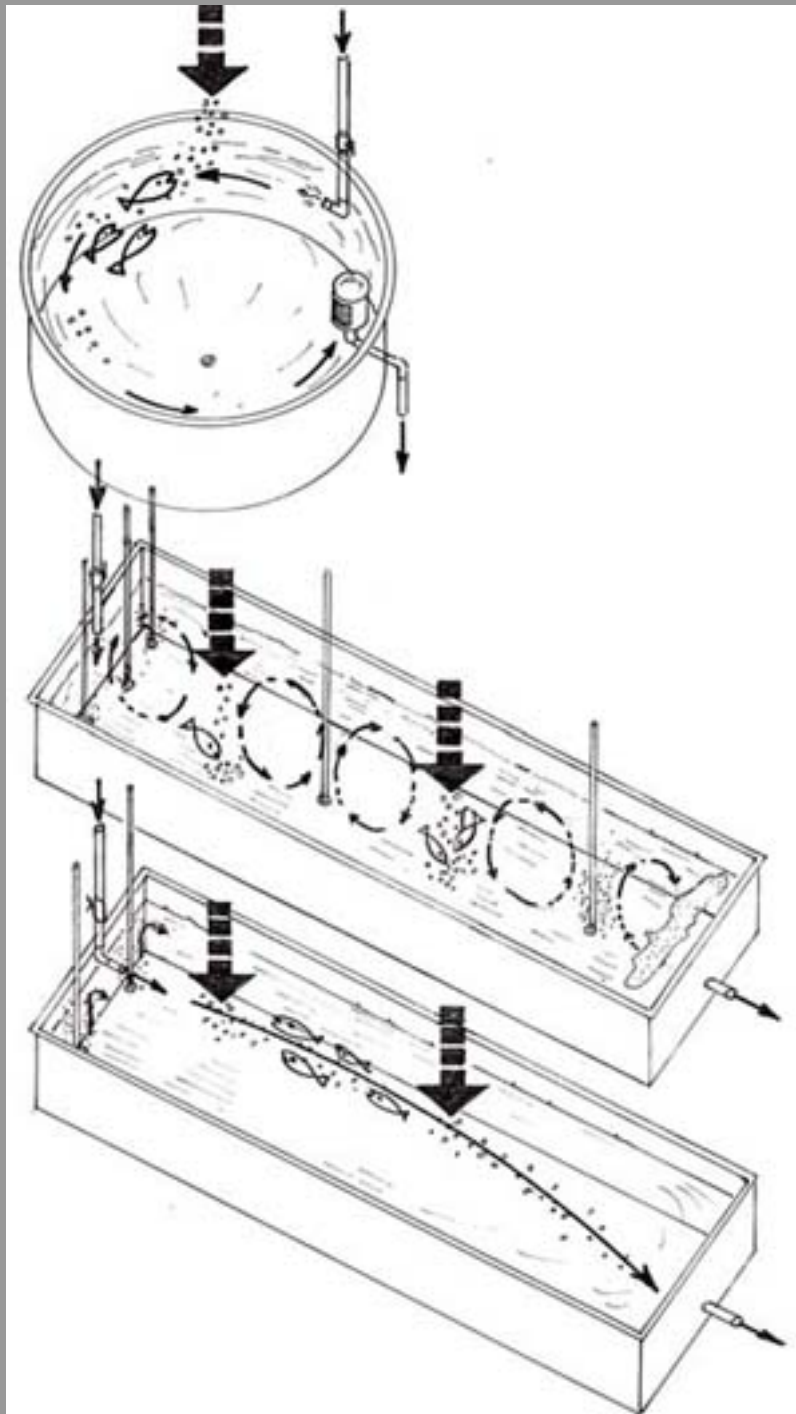

Fig. 22 - Three different solutions of tank shape and water management

The following indications on stocking densities for the two species can be used for the initial trials in a hatchery and will have to be adjusted after the first production cycles.

Gilthead seabream:

- initial stocking density in the larval unit: 200 newly hatched larvae per litre,
- final stocking density in the larval unit: 60 fry per litre (survival rate 30%),
- initial stocking density in the weaning unit: 20 fry per litre,
- final stocking density in the weaning unit: 6 fry per litre (survival rate 90% - density is different because in this sector fish are graded several times).

Seabass:

- initial stocking density in the larval unit: 200 hatched larvae per litre,
- final stocking density in the larval unit: 100 fry per litre (survival rate 50%),
- initial stocking density in the weaning unit: 20 fry per litre,
- final stocking density in the weaning unit: 8 fry per litre (survival rate 80% - density is different because in this sector fish are graded several times).

1.14 WEANING UNIT

The weaning unit is essentially organised as the larval rearing unit. Only the differences between the two units are indicated below.

Due to the larger size of the rearing tanks and to the lower initial stocking densities, the weaning sector requires much more space. It is usually adjacent to the larval rearing unit to facilitate the transfer of fish.

Windows can be installed to reduce the high degree of humidity and to renew the air. As fish grow, they should be gradually adapted to the natural light, although avoiding direct sunlight on the tanks.

The drainage system is also larger than in the larval rearing unit. Large doors are recommended to move equipment as well as large containers on wheels carrying fingerlings at the end of the weaning cycle. Preferably a tarmac road should run along one side of the building to give easy access to lorries used for the delivery of equipment and for transport of fingerlings.

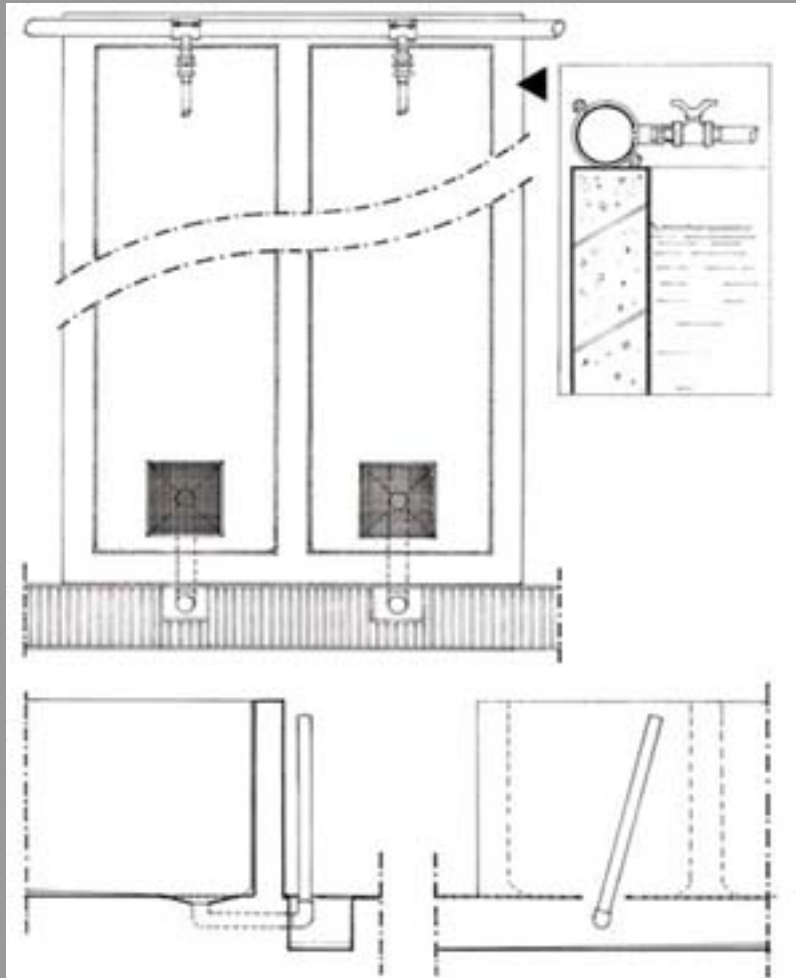

Fig. 23 - Concrete tanks

Production facilities

The weaning tanks are characterised by a larger size than the larval tanks and can be of different shapes. The models most widely adopted by Mediterranean hatcheries are round tanks with flat or slightly concave bottom and the raceway tank. On average, their capacity ranges from 10 to 30 m³, as larger volumes may limit the flexibility required for frequent fish grading, which is a routine practice in weaning. They are usually made of fibreglass and reinforced concrete, but masonry, plastic sheets and rigid PVC are also utilized.

The raceway design is a rectangular tank through which the water current flows from the inlet, placed at one end, to the outlet that is placed at the opposite end. Its hydraulic efficiency is satisfactory, provided that dead zones and stratification are avoided by adjusting the water inflow and aeration. To prevent circular eddies which could accumulate waste and debris in the centre, the length (l) / width (w) ratio should not be lower than 6. For easy management, water depth is usually kept at one metre, whereas the bottom slope is 1-2%.

Often a PVC pipe is used as tank outlet because of the easiness in installation and use. Another very good solution is also a monk with three sets of grooves to:

- prevent fish from escaping (inner screen),
- evacuate the bottom water and sediments by adjusting slabs (central set of grooves),
- keep the desired water level (outer set of slabs).

As the outlet covers the entire section of the tank, this type of outlet is more efficient (due to a reduced clogging risk, and its easy replacement) than a central or terminal drain with a screened pipe. Waste removal is a function of the water speed (linked to renewal rate), and of the fish biomass, since a high number of fish will stir up more sediments. The shape of the raceway is also ideal to harvest and grade fish, and at the same time makes good use of the available floor space, whereas circular tanks waste about 30% of the available room area.

Support systems

The water supply system is similar to the larval rearing unit but bigger. When a recycling system is present, an independent water circuit supplying treated, but not heated, seawater is advisable to increase management flexibility.

The light intensity should be about 1 000 lux and the weaning unit does not require the twilight effect described in the larval rearing unit. Fluorescent tubes are placed over each tank and a power of 20W every 5 m² of water surface is usually sufficient.

This unit requires a few additional power sockets to connect the vacuum cleaner used daily for the removal of the waste accumulated on the tank bottom. A low voltage line is also required to drive the automatic feeders used for the first time in this unit.

Space requirement calculations

The final shift from live to artificial food is achieved in the weaning unit. Combining an increased water renewal and injection of pure oxygen in the tanks, this section may reach a final fish biomass as high as 20 kg/m³. At an individual size of 2-3 grams, this means a final density of 6 to 10 000 fingerlings/m³, which should be used as a general indication for space requirement calculation.

1.15 SUPPORT UNITS

Pumping station

The size of the pumping station depends on the quantity of water needed and on the type, dimensions, and number of pumps installed, including stand-by units. The description of the size calculations for the pumping station can be found in the engineering section of this volume (Part 2).

The site where the pumping station is to be located should be easily accessible, to simplify transport of pumps and other equipment. Moreover, the pumping station should be located as close as possible to the hatchery to facilitate constant surveillance.

The pumping station, even when submersible pumps are used, should be protected at least by a shed and should have good lighting, to facilitate maintenance and eventual repairs. Auxiliary electrical sockets should be provided and, if at all possible, freshwater should be available to facilitate routine maintenance work. If the pumping station is located near the seashore, it should be protected, not only against wave action, but also against salty sea spray.

Horizontal pumps are normally placed inside a small room, together with the electrical control and alarm panels, to ensure a degree of protection against atmospheric agents. This room usually also includes a small workshop where the most commonly used tools for pump maintenance and repair are permanently stored.

The need for a possible urgent intervention should be contemplated in the design stage. When large submersible or vertical pumps are used, the space where they are housed should be large enough to allow technical staff to work safely on the pumps without having to remove them from their seat. Whenever the weight of a pump prevents direct handling, the pumping station should be equipped with an arm and a winch to lift the pumps and to place them on a concrete platform. This platform should be built near the pump seat, for routine maintenance or repairs in case of serious damage.



Fig. 24 - Pumping station

Seawater wells

Along sandy shores, wells dug in the beach are frequently used. On the positive side these wells supply filtered water, often at a constant temperature. However, serious problems can arise if they are over-exploited because they tend to clog the sand bed easily by sucking small particles when pumping. Such wells are suitable when water demand in the hatchery is relatively low. Even in that case, and depending on the size of the sand particle, they will have to be abandoned sooner or later and new wells will have to be dug.

Wells in rocky shores or deep enough to reach a stable but permeable rocky ground are usually very efficient and represent a permanent solution, even if their water may not be of such a good quality as that obtained from sandy wells. Well water often needs treatment before use, because of low oxygen content or because of organic or inorganic pollution. Facilities for this purpose should be considered.

Pumping station to hatchery connection and wastewater treatment

This section refers to the pipes supplying seawater to the hatchery. Pipe length and diameter depends on the location of the pumping station with respect to the hatchery buildings and also depends on the size of its components (pipelines and treatment systems). It has to be designed in relation to the quantity of water to be supplied.

A pipeline is normally used when water is distributed under pressure. It is better to place it under ground level, to cross farm roads without hampering vehicle or trolley circulation. Since pipelines require periodical maintenance and cleaning to remove sand and fouling, they cannot be completely buried. It is best to place them in a trench, well-protected by grids or concrete slabs.

Water distributed under pressure can be filtered through pressure sand filters on arrival at the hatchery. These filters should include an automatic backwash system to increase filtration efficiency and to reduce maintenance.

The seawater effluents of the hatchery should be drained by gravity. The bottom level of the waste water discharge channel must be the lowest level of the whole hatchery/farm hydraulic system. It should also be higher than the final water discharging point, outside the farm.

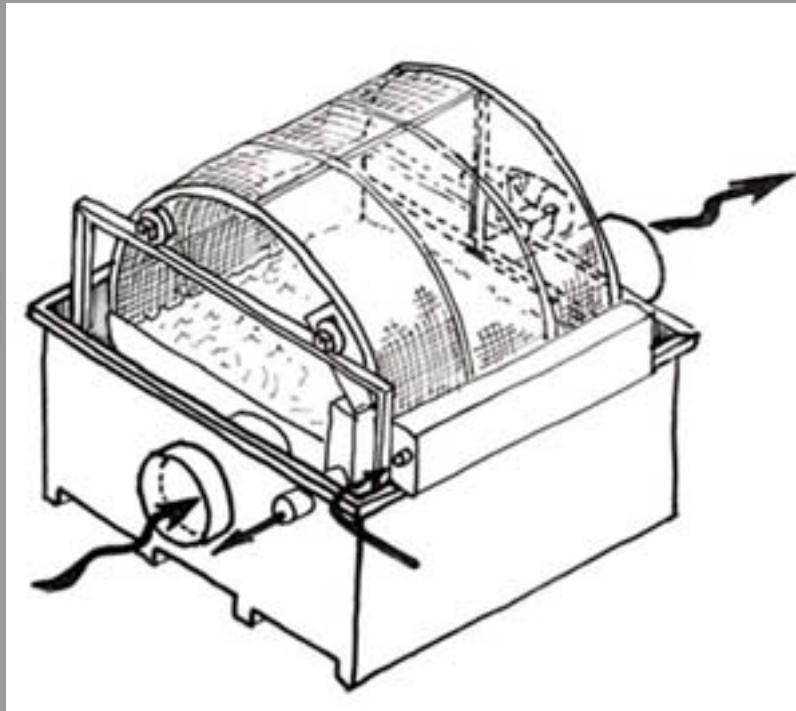

Fig. 25 - Waste treatment

The waste water treatment should be carried out along the discharge channel. It should be based on filtration systems using gravity to move the water rather than pressurized systems. The most suitable system is the drum filter, which is able to retain a large amount of the insoluble organic load (suspended solids) normally present in fish farm effluent. Where space is not a problem, the wastewater produced by the hatchery can be circulated through a settlement tank. In the case of a high organic load, the water passed through a drum filter or sedimentation tank can be directed into one or more earthen ponds where the remaining organic wastes are biologically degraded (lagooning system). This system, however, may require large surfaces depending on the quantity of wastewater produced and to the quantity/type of waste to be treated.

Boiler room

This unit houses the air and water heating system. The capacity of the systems and therefore the size of the room depends on the local climatic conditions. Daily requirements are determined by the difference between external temperatures (air/water) and those to be maintained in the working areas, and by the water/air volumes of the various rearing units.

The room should contain two boilers working in rotation, with each of them having sufficient capacity to provide the calories required during the peak period of the hatchery operations. The double system prevents interruptions in heated water and air supply in case of failure of one boiler. Heating systems are usually based on fuel oil or natural gas burners. From the boiler room, two separate steel pipelines feed the heat exchangers for seawater heating and the air heaters. Each pipeline should be properly insulated to avoid heat losses.

The boiler room should be built according to national/local safety rules, which may establish its minimum size, the aeration requirements and, due to the presence of fuel reservoirs, the minimum distance

between boilers and surrounding buildings. Auxiliary electrical outlets should be provided for maintenance and eventually should be placed outside the boiler room for safety reasons.

While planning the location of this unit, it is important to remember that fuel oil or gas tanks should be next to a road large enough to allow trucks to manoeuvre.

Electricity generator room

As a general rule it would be best to locate hatcheries in sites that could be easily connected to the electricity network. However, one generator (two in case of large hatcheries) should always be ready to supply energy in case of electricity blackouts.

The generator should be installed with its control panel so that, as soon as the necessity arises, it can be automatically (or manually) started to reduce to the minimum the blackout period.

When designing the power network, it is important to bear in mind the peak electrical demand generated when all engines start, which could be four to six times higher than their normal consumption. Delay switches should be installed to stop all the electrical engines and appliances starting simultaneously. Priority should be given to essential equipment, such as pumps and aerators. In order to estimate the size of the emergency generator, it will be necessary to identify the equipment that plays a vital role.

The room housing the generator(s) should be located outside the hatchery. It should be sound-proof, to reduce the noise caused by the diesel engine of the generator. Construction standards should respect the same national/local safety rules as in the case of the boiler room, since fuel is also used in this room.

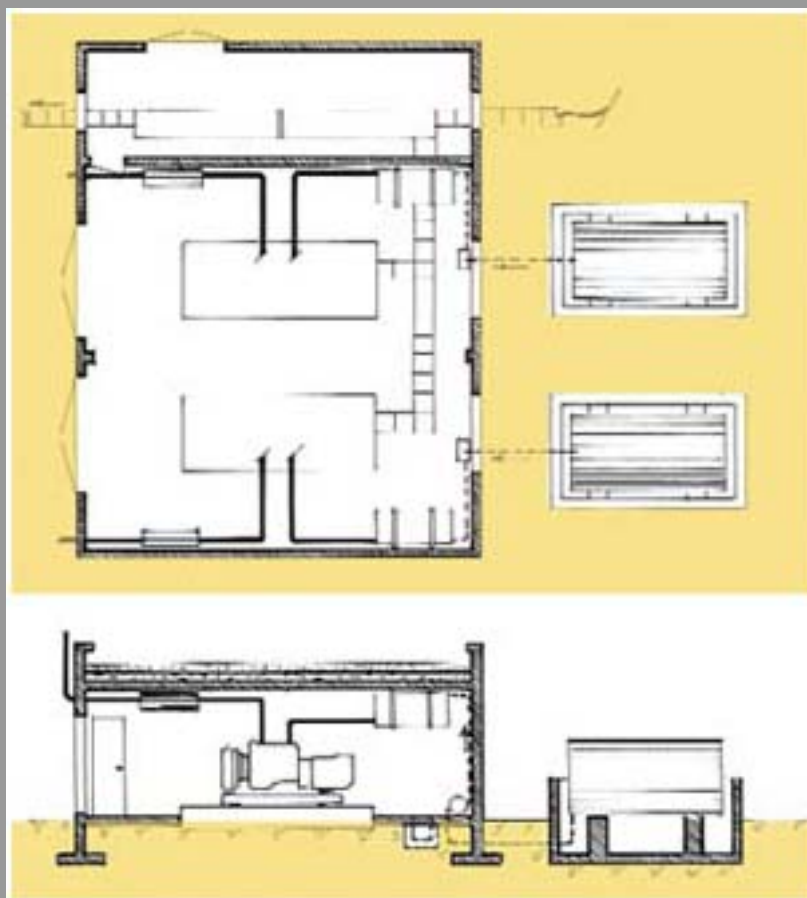

Fig. 26 - The generator room rodents and easily accessible to hand-trolleys.

Workshop

This is the unit where most of the hatchery equipment maintenance and repair takes place. This unit should guarantee that everything runs smoothly when dealing both with routine maintenance and emergencies that may happen during the production season.

Its design follows the rules normally applied when building an industrial workshop: a relatively large free space in the centre of the room equipped with a winch and strong benches around it to facilitate work even on large and heavy equipment. This central space should be large enough to allow the entrance of small vehicles, like tractors or pickups, bringing large pieces of equipment to be serviced. A series of metal benches are placed along the walls, equipped with all the necessary tool-holders. A storeroom is usually attached to the workshop to stock spare parts. The workshop should be adequately illuminated, both inside and outside. It should also be connected to the freshwater and electricity (220 and 380V) circuits.

Feed store

This unit, which in a large fish farm occupies a large storehouse, does not require much space in a hatchery. Only a few hundred kilograms of dry feed for larvae and fry are routinely kept in stock, even during full production periods. The feed should be located in a dry, clean room, protected against

When moist feed is used, a small area inside the hatchery (possibly a separate small room) should be reserved for its preparation. A large bench, easily washable, should be placed close to a large sink provided with a freshwater tap. The area (or room) must also include a deep freezer (-20°C, 400 to 600l capacity) where raw materials (frozen fish or cephalopods) are stored and a large refrigerator (0 to 4°C, 200l capacity) to keep food integrators.

Hatchery laboratory

The hatchery laboratory is a room usually located close to the phyto/zooplankton unit. Its size depends on the type and number of operations and on the number of staff working there. The staff are usually responsible for the phyto/zooplankton unit, as well as for the larval and fry production units. The laboratory should be large enough to allow working together in a comfortable way while performing their routine analyses or carrying out research tests.

Walls with windows may be a convenient characteristic of this room so that the hatchery could be easily kept under continuous surveillance.

As the laboratory is a "wet room", it requires safer standards in particular for electricity circuits and slippery floors should be avoided.

The laboratory should also be equipped with some tile-lined benches for microscopes and water quality analysis and should have a large sink. A small refrigerator is used to store chemical solutions and drugs. Chemical compounds should be stored in a lockable cupboard and be protected against humidity.

Other types of laboratories may be present in the hatchery. Even if it is not a common practice, some farms are actively involved in research programmes to be later applied to production schemes. In such cases, the laboratory should be set up differently according to the research programme to be implemented. If the hatchery has a pathology laboratory, it should be separated from the production units to increase safety and avoid accidental infections.

Furniture in these laboratories should be similar to that of a research laboratory, including, for example anti-corrosion benches for scientific instruments, cupboards with transparent doors for storing glassware and chemical products, and large desks with shelves.

Cleaning areas

Special areas for cleaning procedures are mentioned here because of their particular importance in the routine work. Each production unit should have its own cleaning area where all washable equipment is cleaned after use, disinfected and stored to be readily available.

Cleaning areas should be located far enough from the culture/rearing tanks to avoid any possible contamination with detergents or chemicals used to clean the equipment. It would be essential to plan the various cleaning areas separate from each other to reduce the risk of contamination between different hatchery sections.

Each cleaning area should be large enough to allow the temporary storage of equipment. It should be provided with a table and a wall-rack where the washed equipment can be hung to dry. The concrete floor should have a good slope towards a drain to avoid accumulation of water and detergents and to facilitate washing.

Offices

Offices should be located in an adjacent building rather than inside the hatchery, which is a wet and noisy area not suitable for office work.

The number of offices will depend on the size of the hatchery and, eventually, of the adjacent farm. In a large hatchery there should be one office for the general manager, one for the personnel involved with accounting/clerical work and at least one office large enough to accommodate the technical staff.

The floor space of these offices should be distributed according to their specific activities:

- the general manager normally has frequent contacts with external visitors or may need to hold meetings with his staff. His office should thus be representative and large enough to function as a meeting room;
- the accountant and the clerical staff need appropriate furniture, for example, to store documents (correspondence, equipment and materials orders, etc.). In addition, they will require working desks, tables for telephones, faxes, photocopiers, computers, printers and typewriters;
- the staff responsible for production deal usually with technical matters. They will spend time reading or writing technical documents, and thus they will need a comfortable desk and bookshelves. If computerized control/management systems are used, the main control unit should be kept in this room on a separate table;
- technical staff spend most of their time in the hatchery, but they make frequent calls to their office. They often wear rubber boots, hence an easily washable floor should be planned for this office. This space should be organized more as a common space rather than an office. Staff should be able to keep their property and to socialize there. This room should connect with a dressing room and a lavatory.

1.16 GENERAL RELATIONSHIPS AMONG UNITS AND SYSTEMS

As mentioned above, the size of the hatchery depends mainly on:

- the production targets;
- the production strategy;
- the number of fry per production cycle.

Once these factors have been defined, the relationships among the various units and the different systems are the last step for the design of the final hatchery layout.

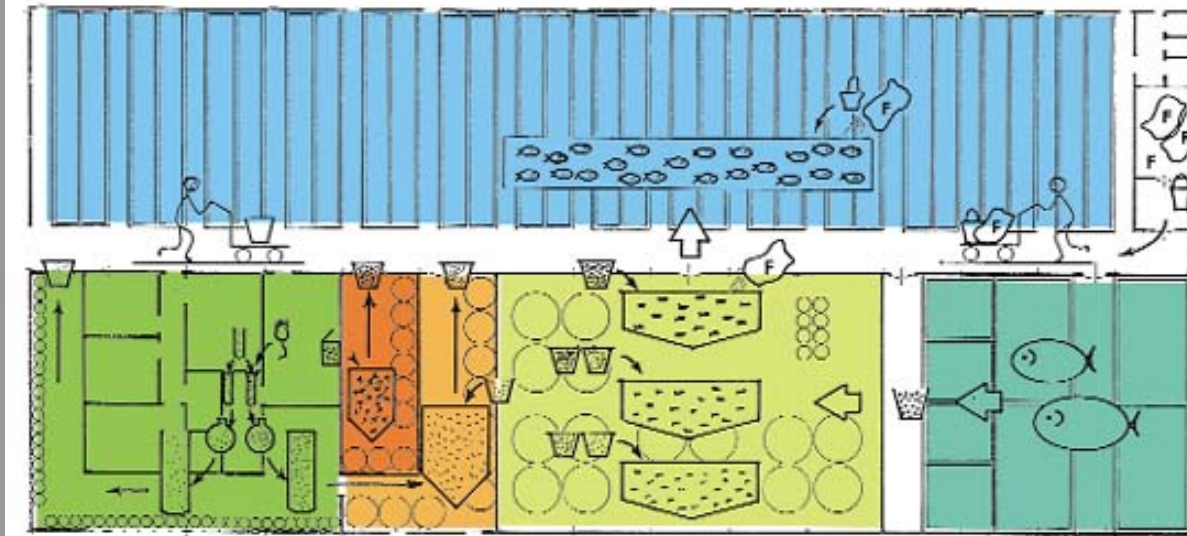

Fig. 27 - Schematic relationships among the units

A well-designed hatchery should also consider production flows, ergonomics of functions and harmonious distribution of systems to facilitate work and increase safety as well as to reduce construction and management costs.

The most important groups of relationships to be taken into consideration are those related to production, systems and work:

- production relationships between the units are those involving production flow, such as for example the typical sequence represented by phyto/zooplankton > larval rearing > weaning.
- systems relationships are those referring to the different engineering and architectural components, such as those between:
 - various support systems. For example, two or more different systems that may share the same passage or the same aerial supports;
 - all hatchery components, as is the case of several services being shared by different units. The laboratory is used for phyto/zooplankton, larvae and fry controls. The feed storage and preparation area is used for larvae and fry feeding. Water conditioning (fine filtration and sterilization) may serve both larvae and plankton units.
- work relationships are those existing between the hatchery systems and their manpower requirements. They contribute to improve the systems ergonomics by directly increasing productivity and security, and by simplifying routine activities.

Due consideration to these three groups of relationships contributes greatly to reduce the investment costs by saving on space and materials. It contributes also to make maintenance easier and cheaper.

In addition to these relationships, the hatchery design should also consider the specific characteristics of each unit. Differences exist in the temperature gradients or lighting conditions adopted in the various units and energy wastes should be avoided.

The design of a hatchery should anticipate possible future expansion. The various units should be assembled in a way that does not compromise the future expansion of the buildings. The larval rearing and weaning units, for instance, are normally designed with a communication on one side; the other

sides should be kept free and tanks, aisles and pipelines should be positioned in such a way as to be easily expanded.

