

# KVK201 TAŞ MALZEME BİLGİSİ VE BOZULMALARI

## DERS 8

ANTİK ÇAĞDA  
MİMARİ VE MİMARİ DÜZENLER

# Yunan Tapınak Planı

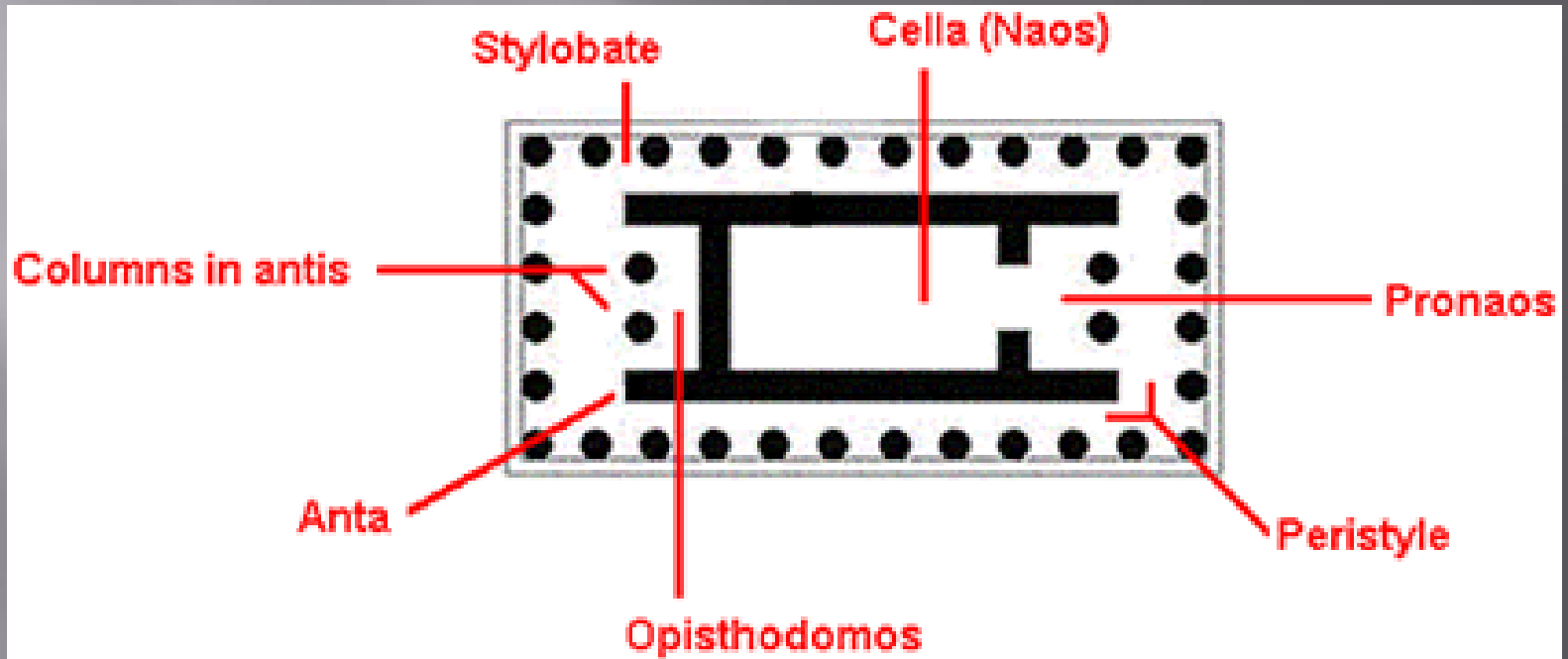

# Yunan Tapınak Tipleri

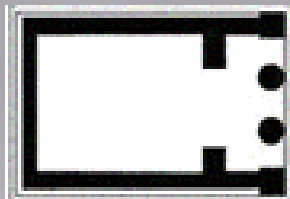

Temple in antis

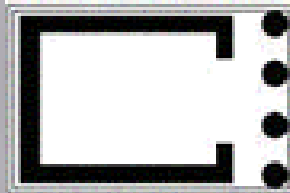

Prostyle

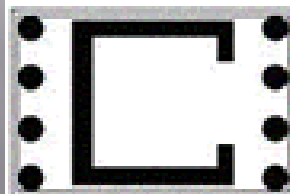

Amphiprostyle

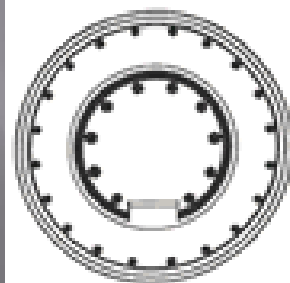

Tholos

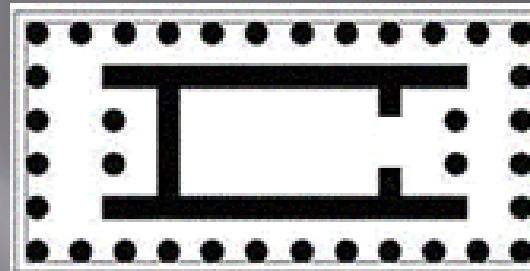

Peripteral

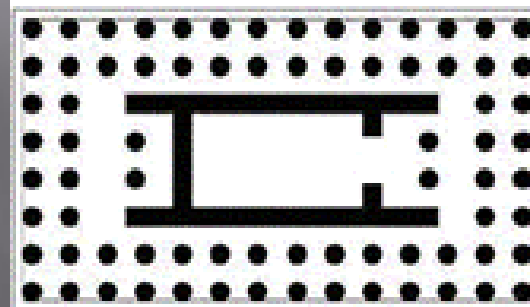

Dipteral

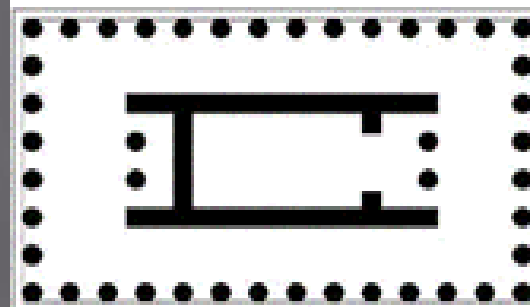

Pseudo Dipteral

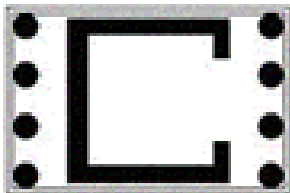
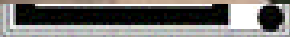

Amphiprostyle

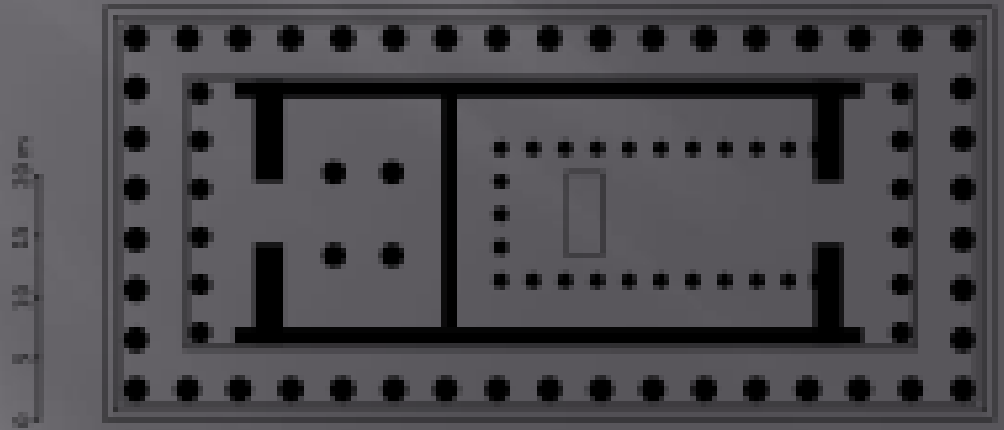

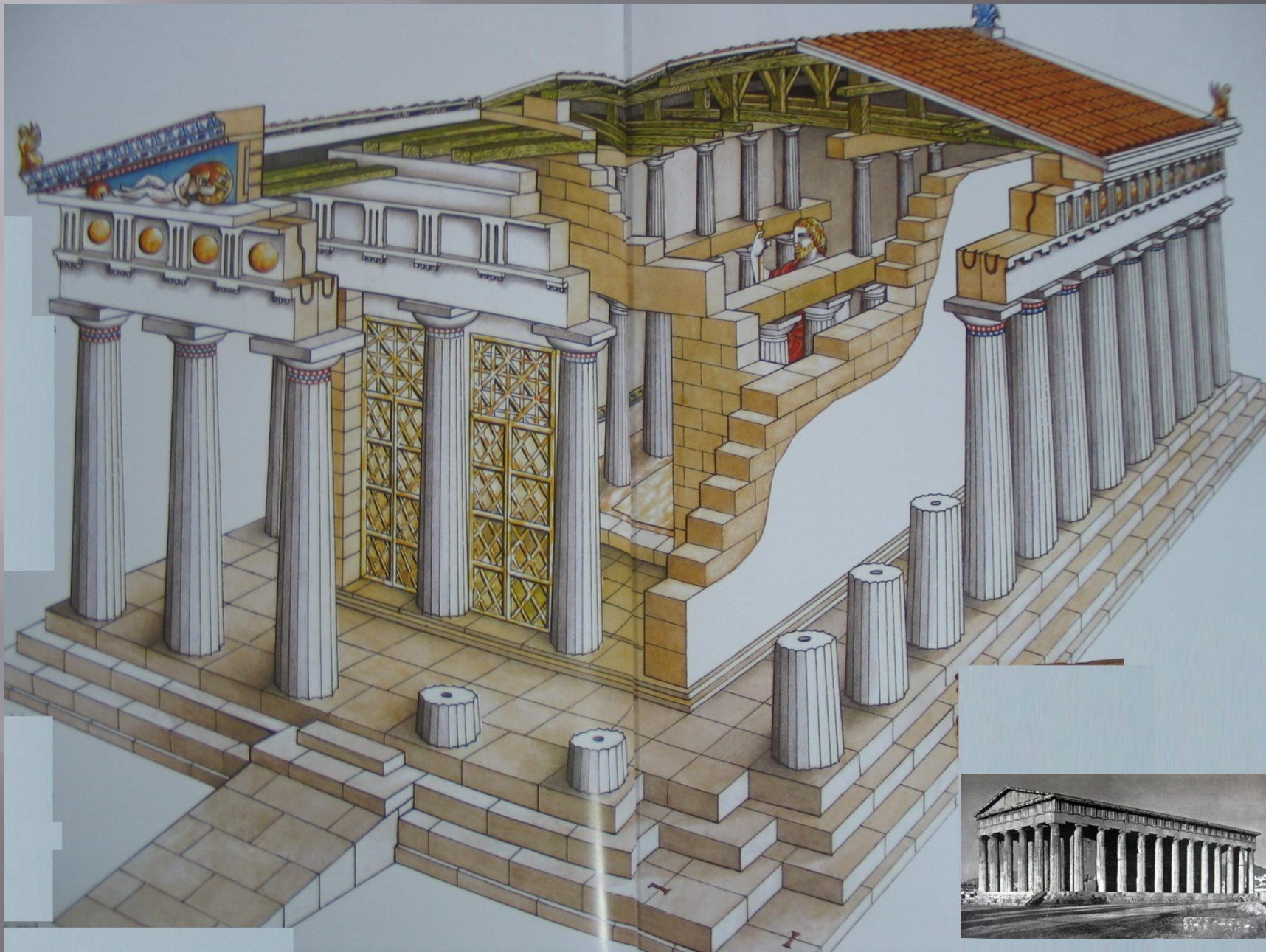

# Dor Düzeni

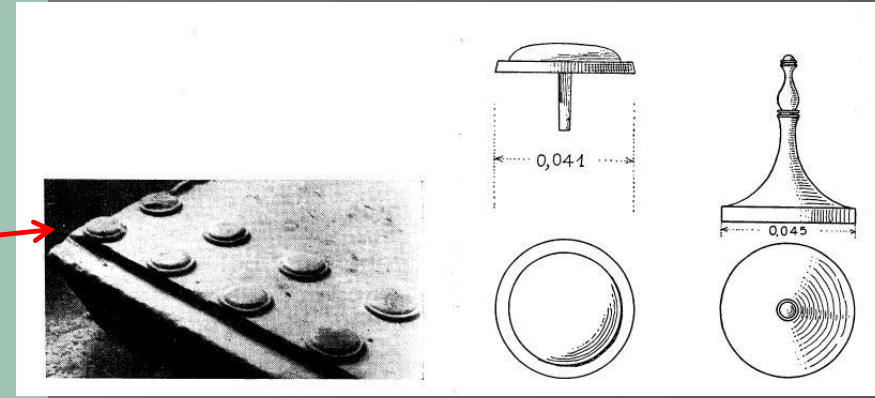
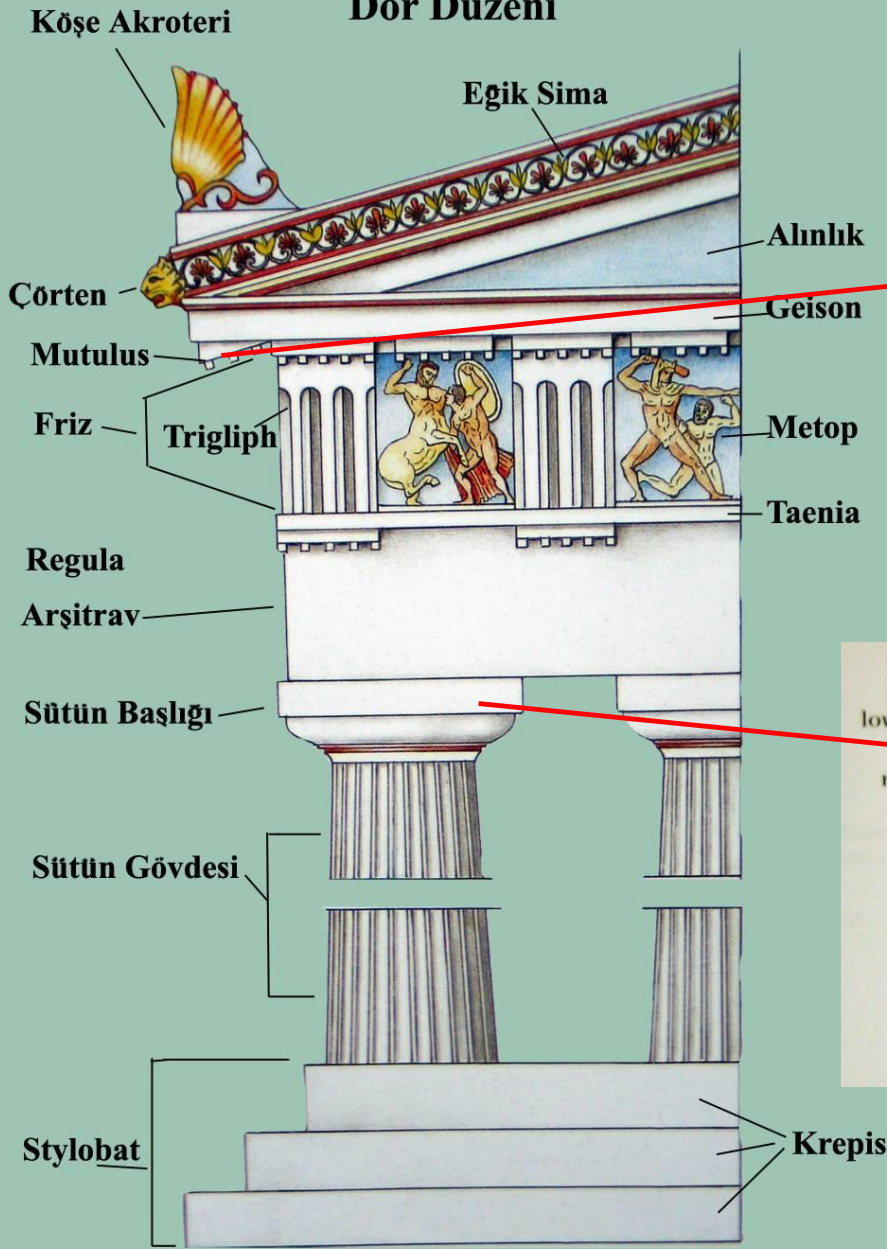

Tibuli Orlandos Les Matreaux de Construction s106 fig 70-71

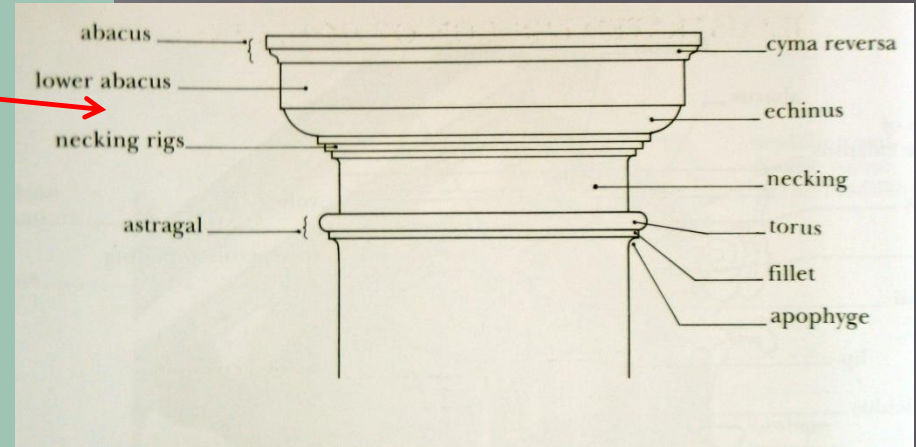

Antik Yunan ve Roma uygarlıklarında mimari elamanlar, heykeltıraşlık eserlerinde olduğu gibi çeşitli renklerde boyalı idi.

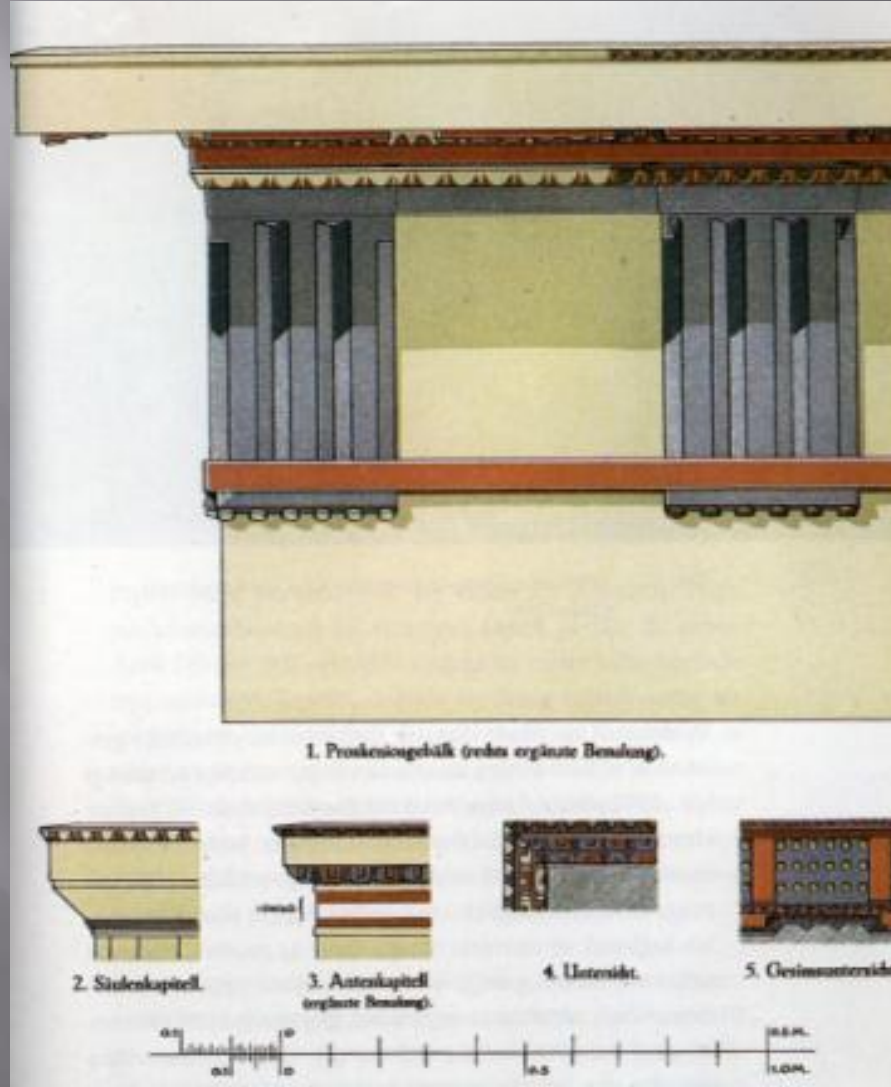

# Magnesia Artemis Tapınađı

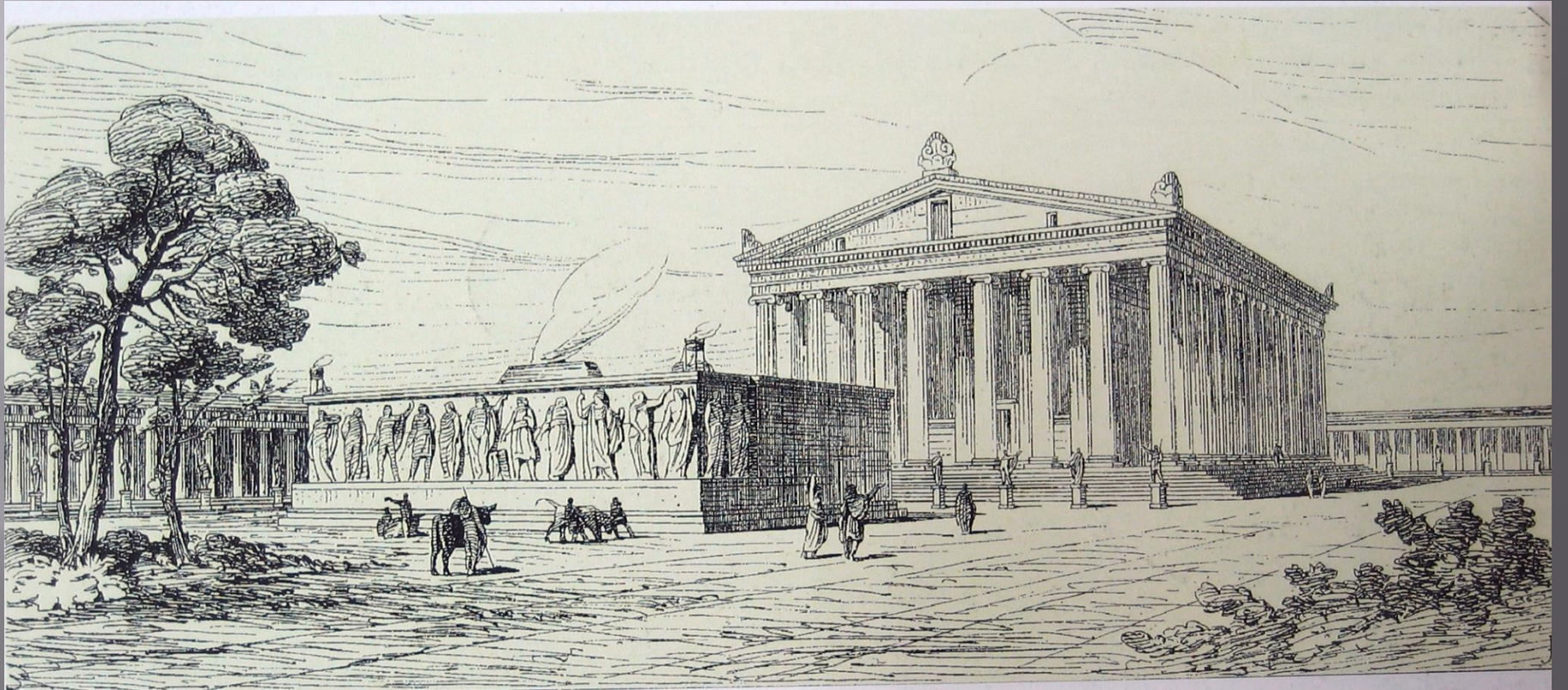



# İon Düzeni

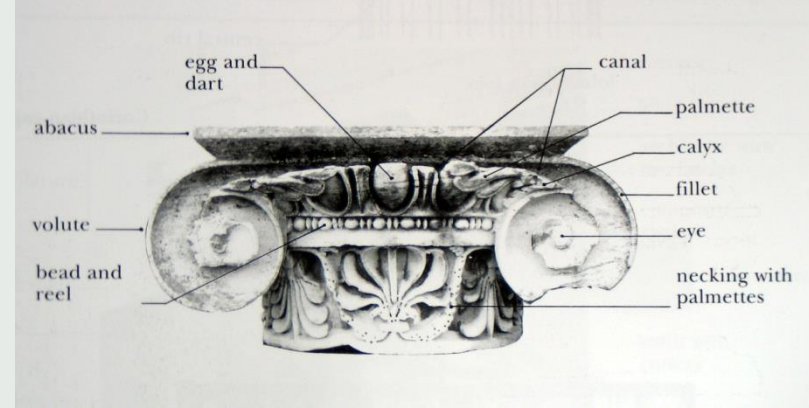
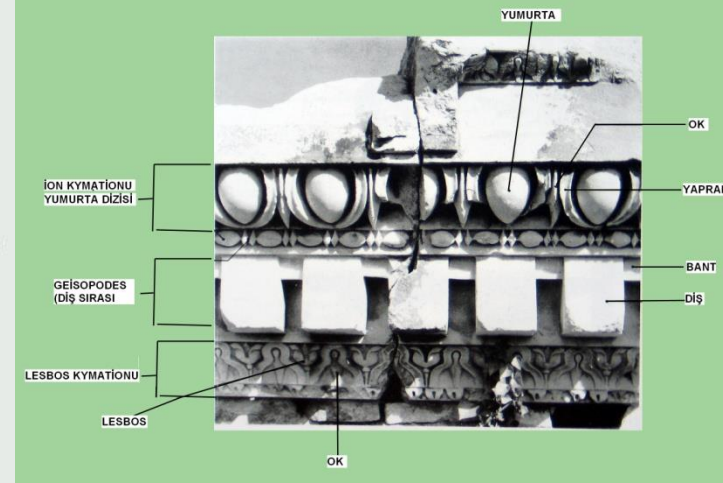
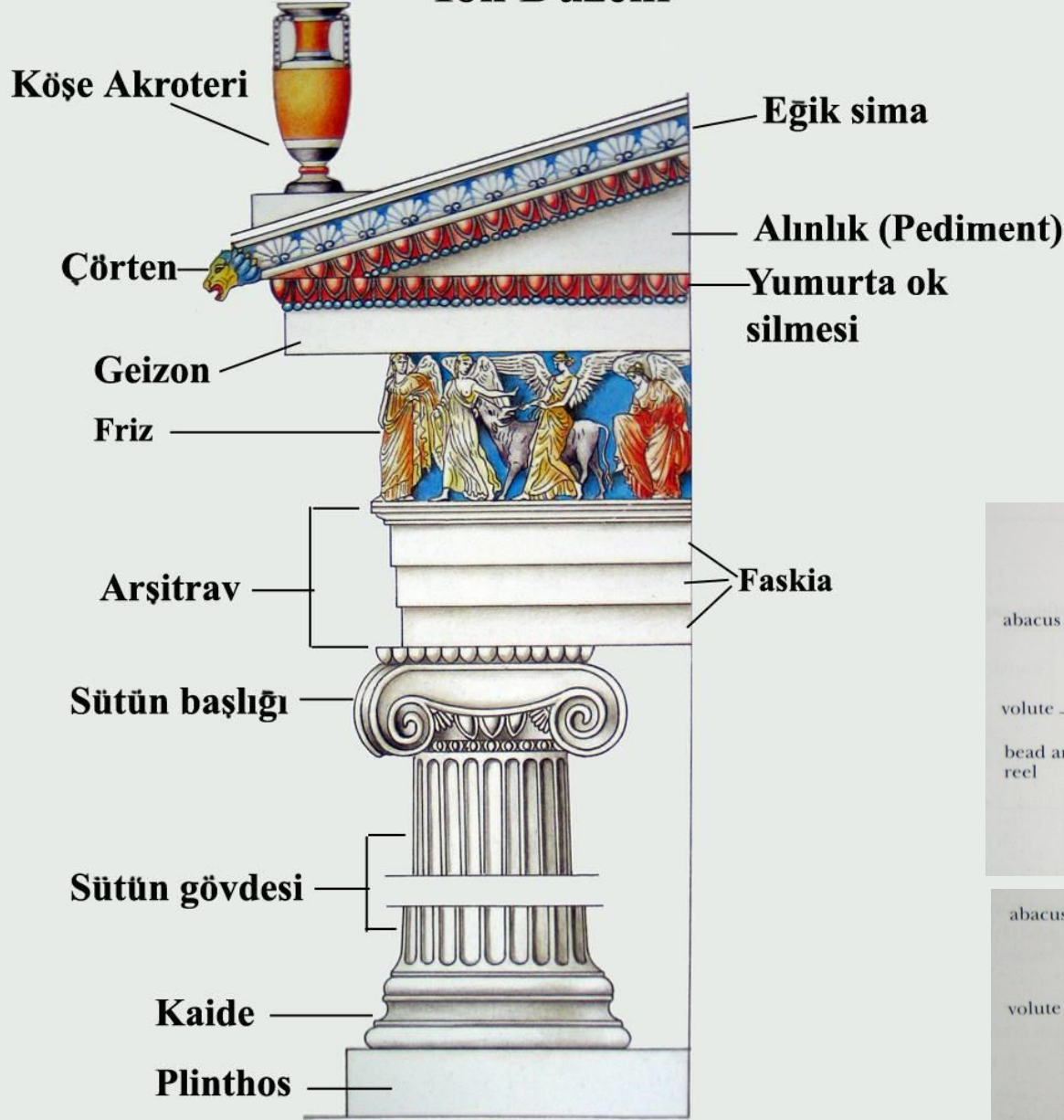

Antik Yunan ve Roma uygarlıklarında mimari elamanlar, heykeltıraşlık eserlerinde olduğu gibi çeşitli renklerde boyalı idi.

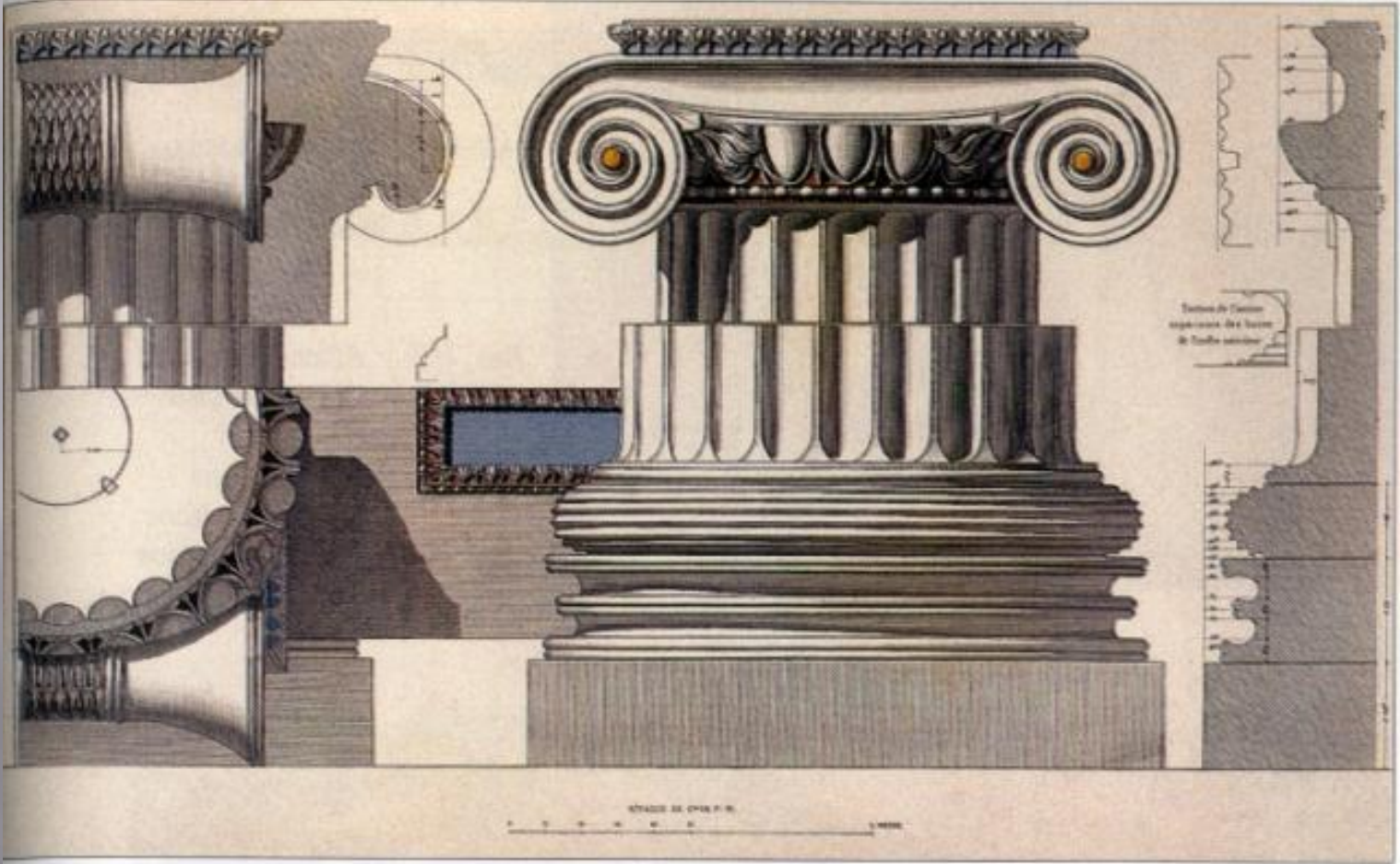

*Athena Tapınağı. Boyalı halleriyle kaide, başlık ve soffitin rekonstrüksiyonu.*

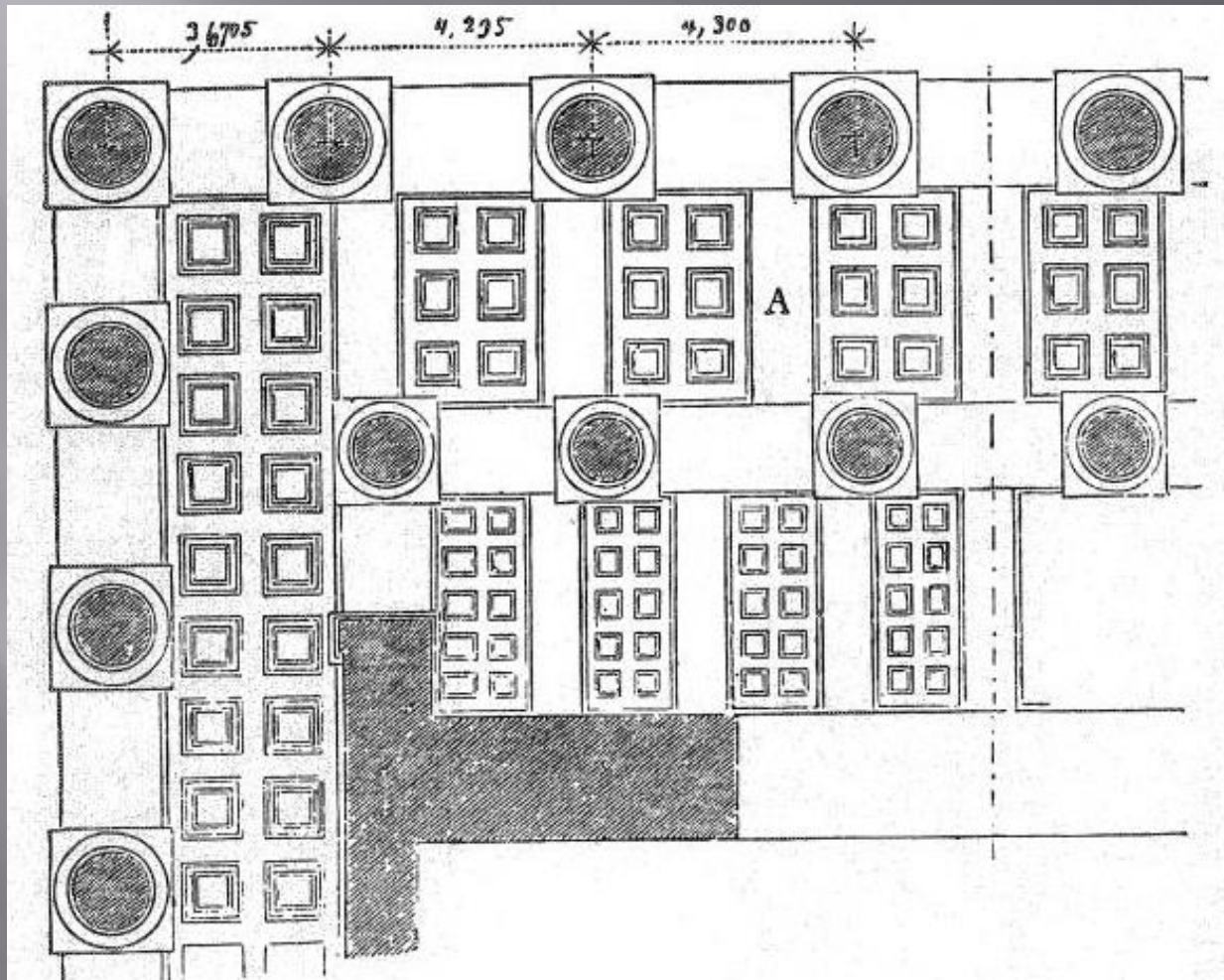

## Dor Düzeni

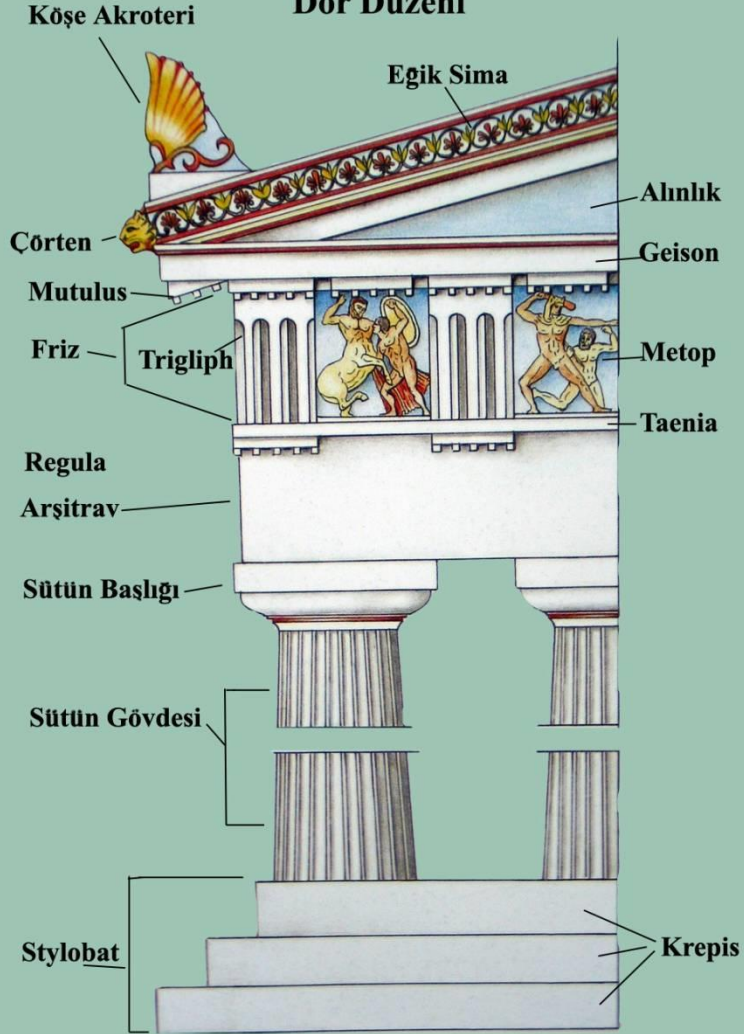

## İon Düzeni

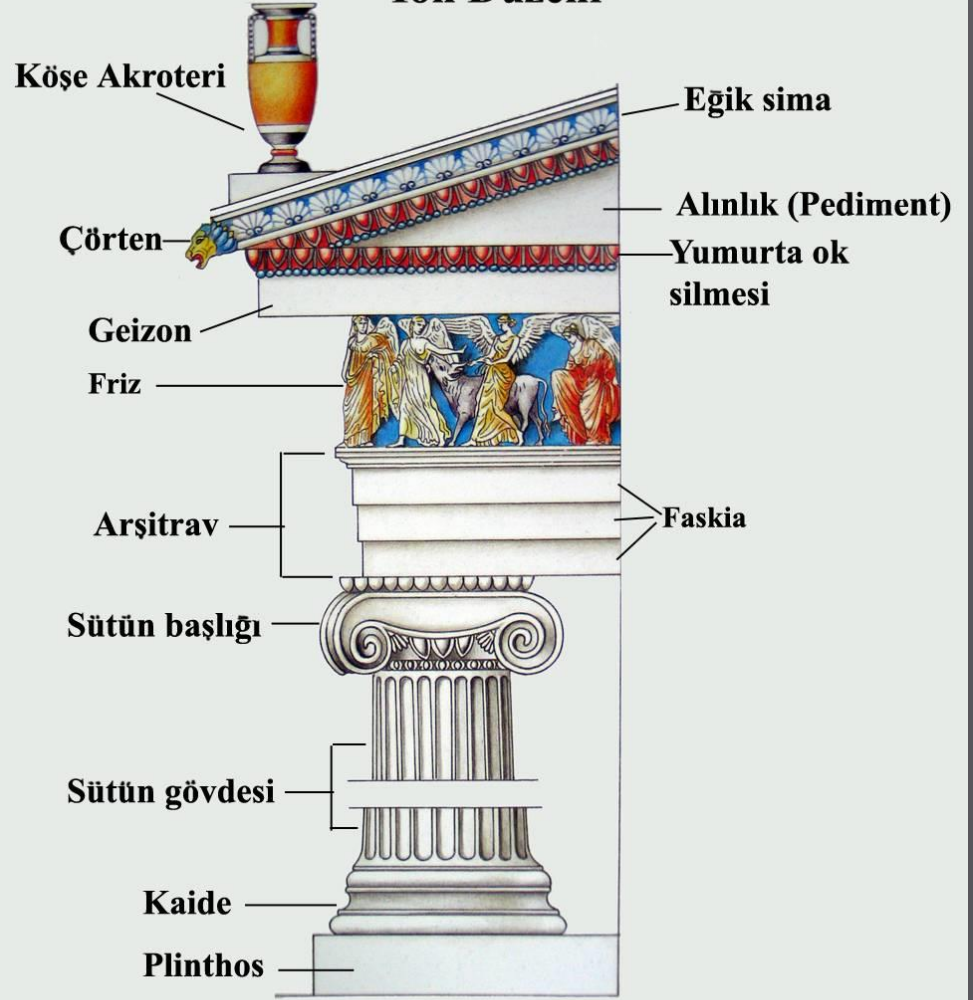

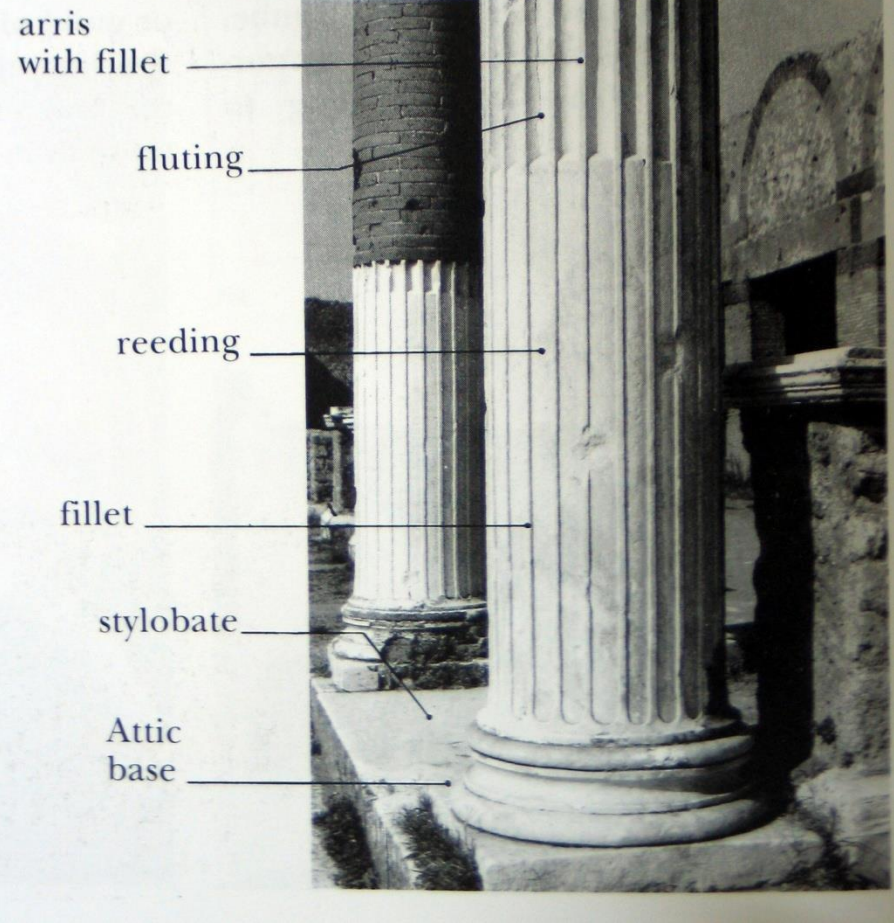

Columna caelata

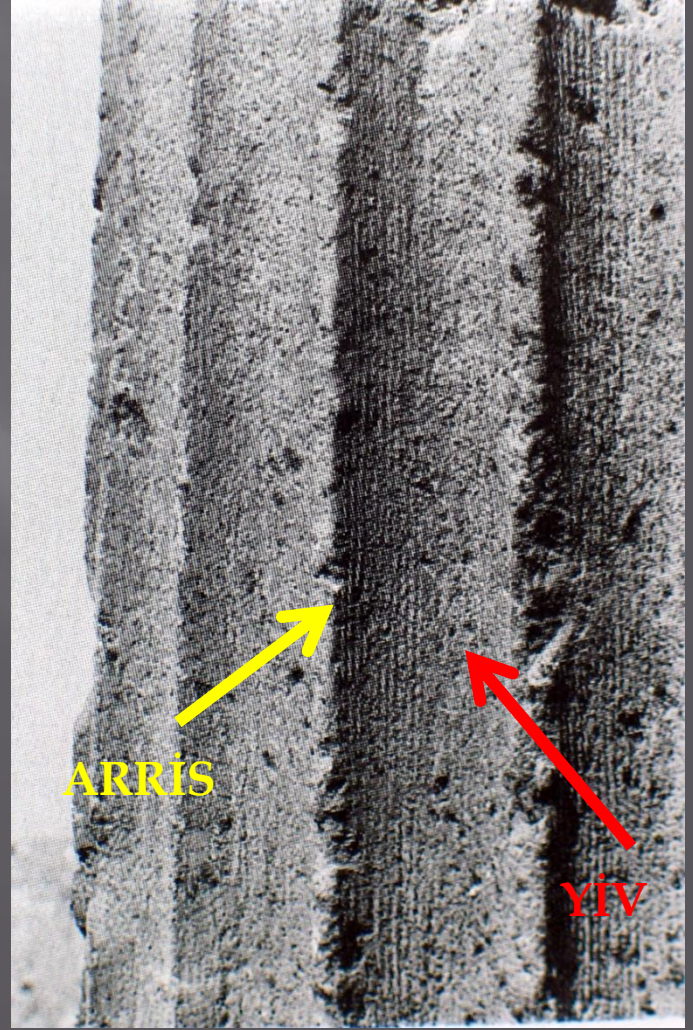

# Korint Düzeni

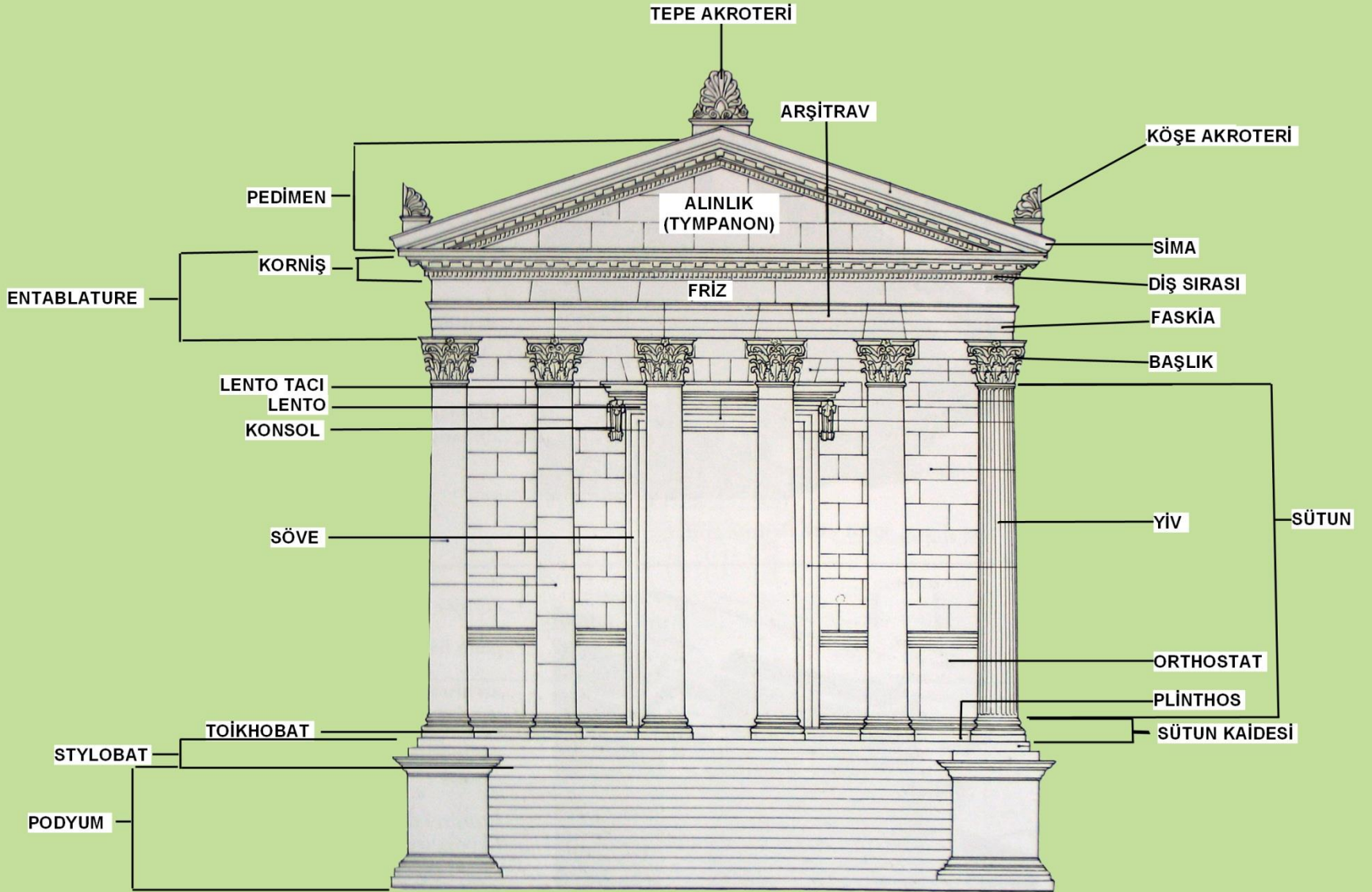

# Kyma Rekta ve Reversa

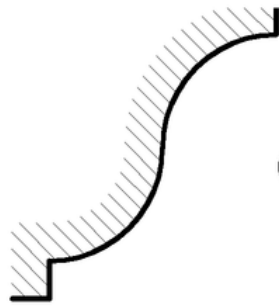

CYMA RECTA

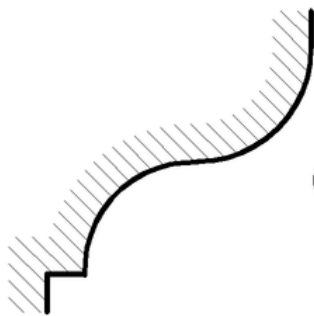

CYMA REVERSA

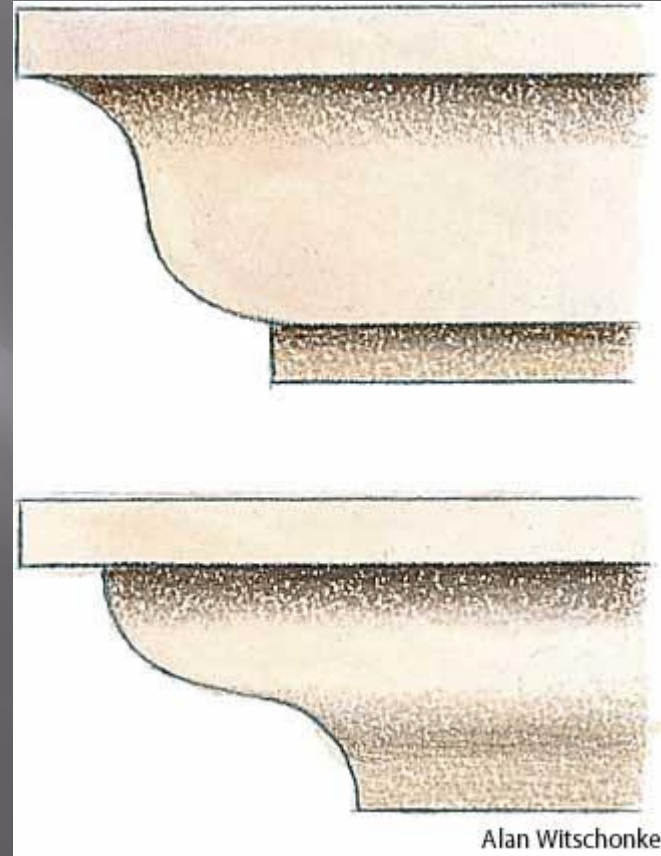

Alan Witschonke

# ion ve Lesbos Kymationları

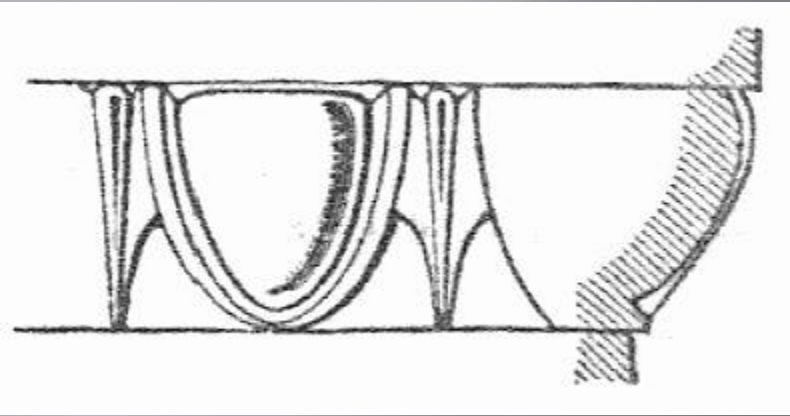

İon kymationu

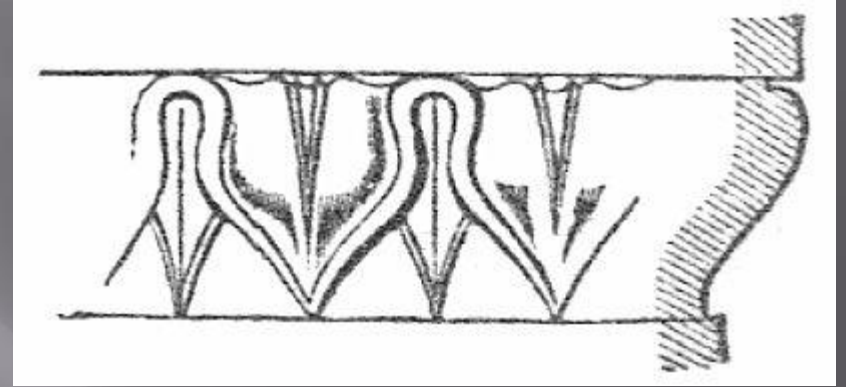

Lesbos kymationu

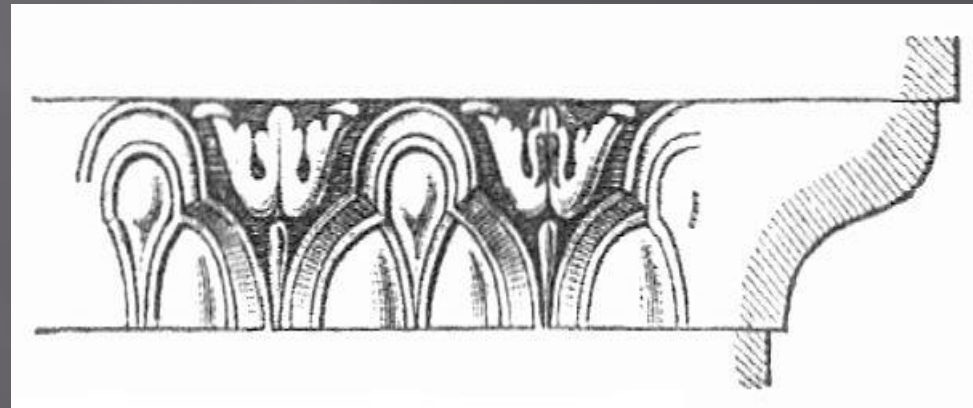
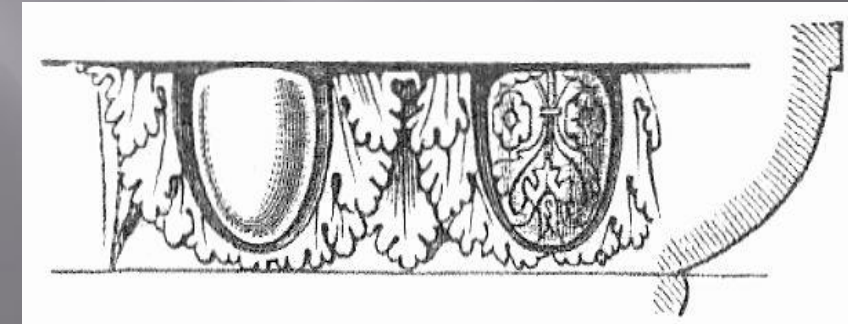



Antik Yunan ve Roma uygarlıklarında mimari elamanlar, heykeltıraşlık eserlerinde olduğu gibi çeşitli renklerde boyalı idi.

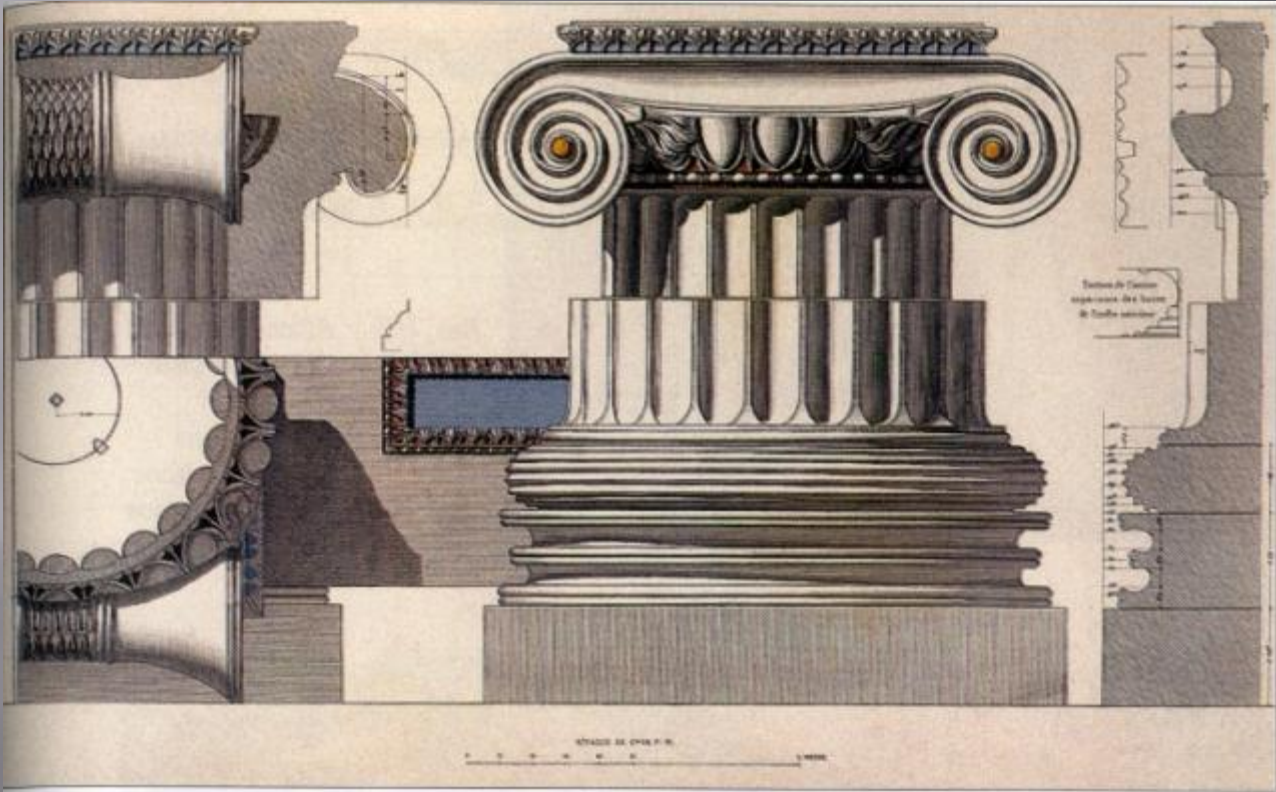

*Athena Tapınağı. Boyalı halleriyle kaide, başlık ve soffit in rekonstrüksiyonu.*

Antik Yunan ve Roma uygarlıklarında mimari elamanlar, heykeltıraşlık eserlerinde olduğu gibi çeşitli renklerde boyalı idi.

