

MICROSCOPE and

STARCH EXAMINATION

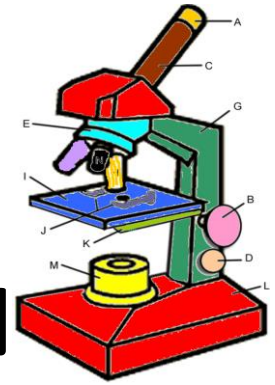
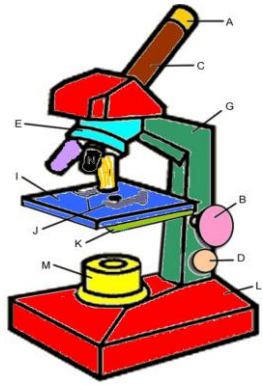

Identification and control of pharmaceutical drugs falls within the scope of pharmaceutical botany and pharmacognosy sciences.

The aim of the «Practice in Pharmaceutical Botany» course is,

- a) Diagnosis
- b) Purity control
- c) Quality control

of drugs and to inform the pharmacy students about these matters.

Methods used for this aim:

1-ORGANOLEPTIC EVALUATION:

These are sensory-based methods used to identify characters that are visible to the naked eye, to the **whole or powdered drugs**.

- a) Shape and size :
- b) Color and appearance:
- c) Fracture surface
- d) Odor and taste:
- e) Picture:

These characters are important for this method.

1. Organoleptic Evaluation

- Evaluation of drug by color, odor, size, shape, taste, and special features including surface characteristic (touch, texture, etc).
- Since the majority of information on the identity, purity and quality of material can be drawn from these observations, **they are of primary importance before any further testing can be carried out**

1-ORGANOLEPTIC EVALUATION:

TEST	OBSERVATION
Colour	Light yellow Light brown Dark brown to violet Red Orange Green
Odour	Characteristic Odourless
Taste	Aromatic Aromatic & pungent Sweet Bitter
	Mucilagenous Astringent

2-MICROSCOPICAL EVALUATION:

- Drugs have their own **unique texture** and **cell/tissue structures**.
- These characteristic cell and tissue morphology play an important role in drug **diagnosis**, **purity control** and **quality control**.

Microscopical Evaluation

- **Microscopical technique** provide detailed information about the crude drugs by virtue of its main analytical uses.
- Used to visualize fine structure of minute objects and thereby confirm the structural details of the plant drugs under evaluation.
- These techniques can be used in the determination of the optical as well as micro-chemical properties of the crude drug specimens under study.

- Microscopical inspection of crude drugs from plant origin is essential for identification of the grounded on powdered material.
- It can provide supporting evidence which in combination with other analytical parameters can be used to obtain full evidence for standardization and evaluation of herbal drug

PURPOSE OF MICROSCOPICAL STUDIES IN THE PRACTICE in PHARMACEUTICAL BOTANY COURSES:

-To know the characteristic elements of drugs which are powdered or sectioned and to learn how they look under microscope.

Only in this way it will be possible to diagnose the drugs correctly.

MICROSCOPE

-*micro-* (Gr.)= small

+

- *skopein*-(Gr.) = looking, seeing

It is an instrument that allows images to be examined by magnifying objects that are too small to be seen by the naked eye with the help of several kinds of lenses.

Light Microscope: The light source is the visible wavelength from the sun or any lamp, and the magnifier is the type of microscope used by glass lens systems.

1-Mechanical Parts

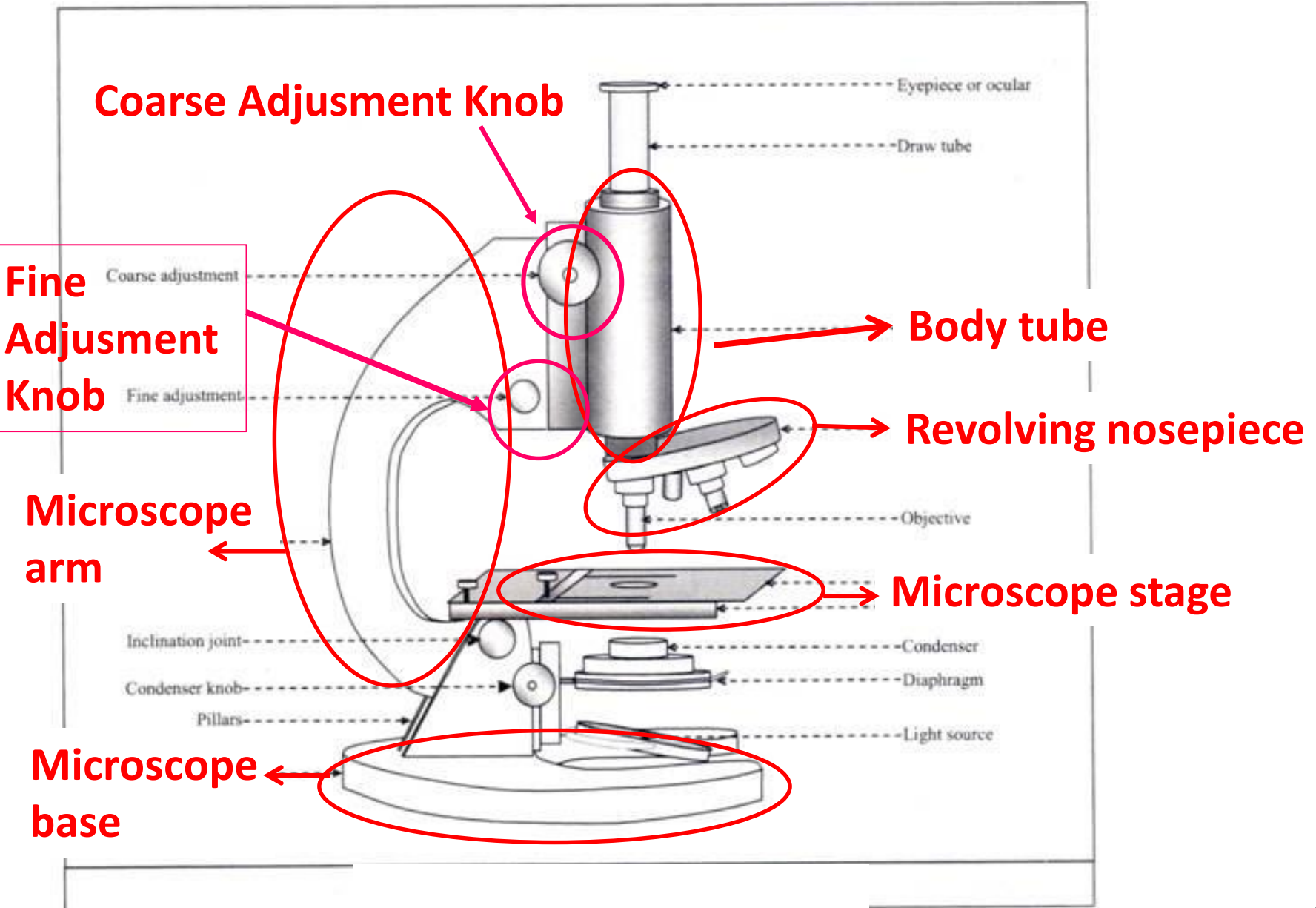

2-Optical Parts

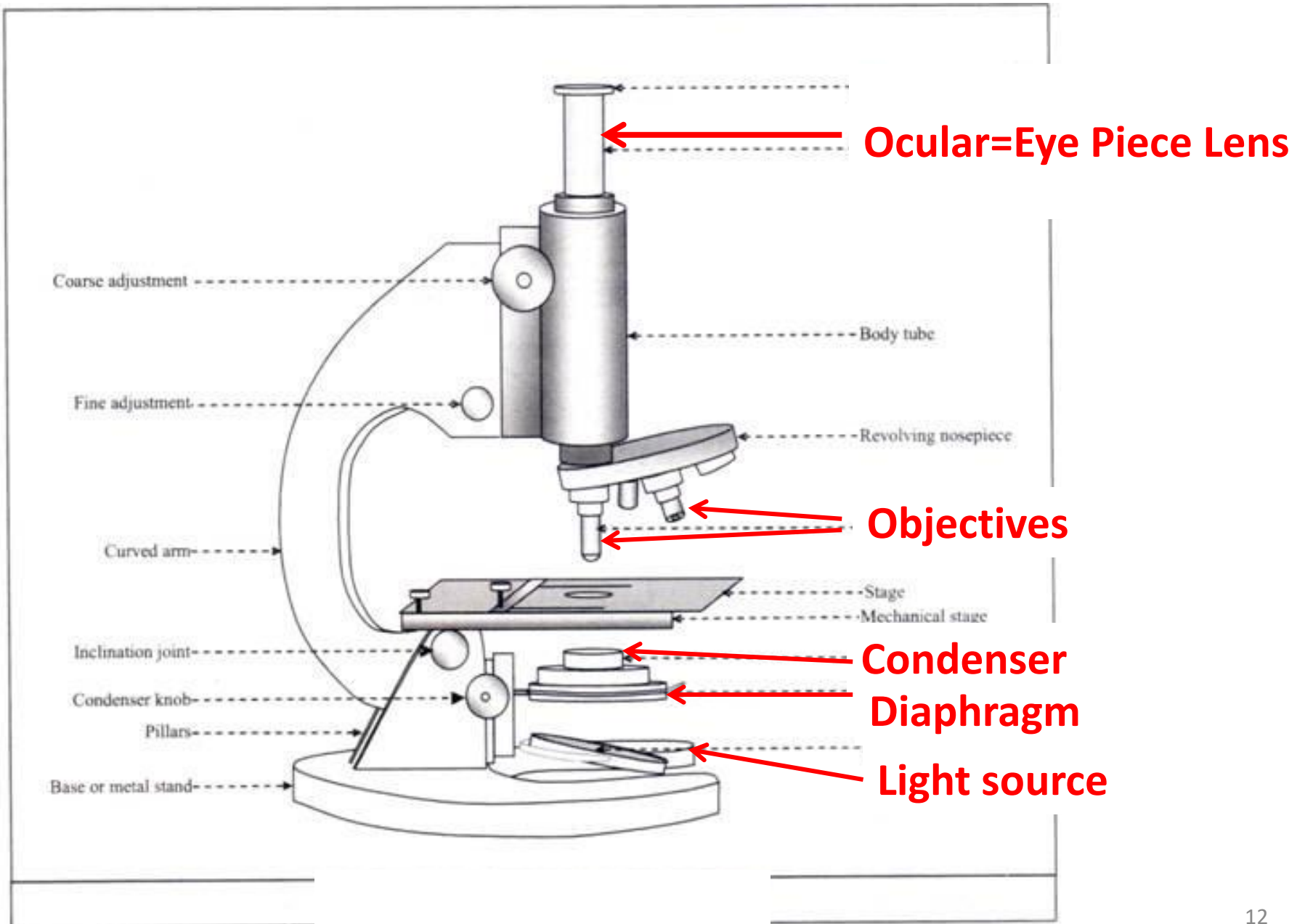

Objectives (Objective lenses)

There is a direct **correlation** between the magnification power and the length of the objectives.

By using the mirror, direct the light beam to the visual axis of the microscope

Mirror has two faces

1. Concave (for lamp on the bank)
2. Plane (for sunlight)

Preparation of Specimen for Microscopic Observation

Two types of microscope glass slides are used for making the preparation:

In order to observe the microscope, it is necessary to make the objects visible in the microscope. The preparation involves the process of making the object visible under the microscope.

Using proper amount of powdered drug for sample preparation is important:

*Turn the revolving nosepiece (2) so that the **lowest power objective lens** (4x) is clicked into position.

*Place the microscope slide on the stage (6) and fasten it with the stage clips.

*Make light setting.

*Adjust the diaphragm (7) and light intensity for the greatest amount of light.

NOTE: (with low power objectives you might need to reduce the light intensity or shut the condenser).

*Look through the eyepiece (1) *Move the microscope slide around until the sample is in the centre of the field of view (what you see).

and turn the **COARSE ADJUSTMENT KNOB** (4) so the body tube moves up and down -ward.

*Make a clear view by using **COARSE ADJUSTMENT KNOB** (4).

*When you have a clear image of your sample with the lowest power (x4) objective, you can change to the next (More powerful: x10) objective lenses. Make X10 objective lenses clicked into position.

*Clear your image by using **FINE ADJUSTMENT KNOB.**

*When you have a clear image of your sample with the X10 objective lenses, you can change to the next (Most powerful: x40) objective lenses. Make X40 objective lenses clicked into position.

*After clearing your image by using **FINE ADJUSTMENT**
KNOB.

You can draw the details of your object to be observed to your report.

VERY IMPORTANT NOTE-1!

****When you start, please click the low power lens (X4) into position and place the slide on the microscope stage.**

***Do not let the objective lens touch the slide!**

***When finished, click the low power lens (X4) into position and remove the slide.**

***WHILE PLACING and REMOVING the SLIDE, the low power lens (X4) must be clicked in the position.**

VERY IMPORTANT NOTE-2 !

***COARSE ADJUSTMENT KNOB IS ONLY FOR LOWEST POWER OBJECTIVE LENS (4X) AND DO COARSE ADJUSTMENT ONLY!!!**

***WITH POWERFUL OBJECTIVE LENSES (X10 AND X40) PLEASE USE ONLY FINE ADJUSTMENT KNOB TO CLEAR THE IMAGE AND TO DO FINE ADJUSTMENT!!!!**

Starches

Starches are carbohydrates which consist of a large number of sugar units linked together by glycosidic bonds.

Many green leafy plants produce starches as energy storage source.

Starch is located in most plant tissues, particularly in storage organs such as rhizomes, tubers, and grains.

- **It is the most basic carbohydrate in human diet.**
- **It is abundant in foods such as potatoes, corn, wheat, rice.**
- **Starch is tasteless, odorless; A powder that is insoluble in water and alcohol.**
- **It is used as a thickener in food industry.**

It is used as an excipient in pharmacy

EXCIPIENT:

- Usually inert substance (as gum arabic or starch) that forms a vehicle (as for a drug)
- Any of various inert substances added to a prescription to give the desired consistency or form

Structure of a Starch Grain

The shape of the starch granules varies according to the plant type.

Features that allow identification of starch grains include: shape of the granules, presence of hilum and growth rings, type of hilum (punctiform, cross-shaped..), and also testing for presence of starch using iodine (staining black to blue in presence of starch).

THE POSITION OF THE HILUM IS USEFUL FOR RECOGNIZING THE STARCH GRANULE.

-Hilum position can range from central location, referred as «**CENTRIC HILUM**» to a completely asymmetrical position, known as «**ECCENTRIC HILUM**».

Starches to be investigated

Drug Name: Amylum Solani (Potato starch)

Plant Name: *Solanum tuberosum* (Potato)

Investigation medium: Distilled water

Microscope Magnification: 10x40

Potato starch contains typical large oval spherical, oyster-shaped granules; their size ranges between 5 and 100 μm .

Half-Compound Starch Grains are composed of aggregates of 2 or more granules and commonly enclosed by growth rings.

Compound Starch Grains are composed of aggregates of 2 or more granules and not enclosed by growth rings.

Iodine test (Try it only For Potato Starch)

Write your observation: «The color of the grains turned to blue-black after iodine application.

Drug Name: Amylum Tritici (Wheat starch)

Plant Name: *Triticum vulgare* (Wheat)

Investigation Medium: Distilled water

Microscope Magnification: 10x40

Their size ranges between 5 and 45 μm .

SPHERICAL Shaped granules, but some large granules changed into lenticular shape (side view of the grain), while small granules remained spherical.

Drog Adı: Amylum Maydis (Corn starch)

Bitki Adı: *Zea mays* (Corn)

Investigation Medium: Distilled water

Microscope Magnification: 10x40

***Granules are polyhedral (çok yüzlü) and subspherical.**

***No growth rings can be observed.**

***Hilum centric, 2- to 5- stellate cleft.**

***All granules are simple.**

***Their size ranges between 2 and 30 μm .**

Drog Adı: Amylum Oryzae (Rice starch)

Bitki Adı: *Oryza sativa* (Rice)

Investigation Medium: Distilled water

Microscope Magnification: 10x40

***Compound (from 2 to 100 components) grains with an angular outline (They are polyhedral with sharp angles).**

***No hilum, no growth rings**

***Their size ranges between 2 and 10 μm .**