

OPTICAL FIBER ATTENUATION MEASUREMENT

Introduction

Attenuation is the loss of optical power as a result of absorption, scattering, bending, and other loss mechanisms as the light travels through the fiber. The total attenuation is a function of the wavelength λ of the light. The changes in the average optical power P along the fiber transmission line can be defined as;

$$dP/dz = -\alpha P$$

where α is the attenuation coefficient. The attenuation coefficient or attenuation rate α is given by $\alpha(\text{dB/km})$. Here the distance between the two points is taken into account by the km unit. If P_{in} is the power launched at the input end of a fiber of length L , the output power P_{out} is given by,

$$P_{\text{out}} = P_{\text{in}} \exp(-\alpha L)$$

It is customary to express α in units of dB/km by using the relation,

$$\alpha (\text{dB/km}) = -\frac{10}{L} \log_{10} \left(\frac{P_{\text{out}}}{P_{\text{in}}} \right) \approx 4.343\alpha$$

Consider a 30-km long optical fiber that has an attenuation of 0.8 dB/km at 1300 nm. Suppose we want to find the optical output power P_{out} if 200 μW of optical power is launched into the fiber:

$$z = 30 \text{ km}, \alpha = 0.8 \text{ dB/km}, P(0) = 200 \mu\text{W}$$

$$\alpha = 10 \times \frac{1}{z} \log \left[\frac{P(0)}{P(z)} \right] \Rightarrow 0.8 = 10 \times \frac{1}{30} \log \left[\frac{200 \mu\text{W}}{P(z)} \right]$$

$$2.4 = 10 \times \log \left[\frac{200 \mu\text{W}}{P(z)} \right] \Rightarrow \left[\frac{200 \mu\text{W}}{P(z)} \right] = 10^{2.4} = 0.7962 \mu\text{W}$$

OPTICAL FIBER ATTENUATION MEASUREMENT

A continuous 12 km long optical fiber link has a loss of 1.5 dB/km.

- i) What is the minimum optical power level that must be launched into the fiber to maintain an optical power level of $0.3 \mu\text{W}$ at the receiving end?
- ii) What is the required input power if the fiber has a loss of 2.5 dB/km?

Solution :

$$z = 12 \text{ km} \quad \alpha = 1.5 \text{ dB/km}$$

$$P(0) = 0.3 \mu\text{W}$$

- i) Attenuation in optical fiber is given by,

$$\alpha = 10 \times \frac{1}{z} \log \left(\frac{P(0)}{P(z)} \right)$$

$$1.5 = 10 \times \frac{1}{12} \log \left(\frac{0.3 \mu\text{W}}{P(z)} \right)$$

$$\log \left(\frac{0.3 \mu\text{W}}{P(z)} \right) = \frac{1.5}{0.833}$$

$$= 1.80$$

$$\left(\frac{0.3 \mu\text{W}}{P(z)} \right) = 10^{1.8}$$

$$P(z) = \left(\frac{0.3 \mu\text{W}}{10^{1.8}} \right) = \frac{0.3}{63.0}$$

$$P(z) = 4.76 \times 10^{-9} \text{W}$$

$$\text{Optical power output} = 4.76 \times 10^{-9} \text{W}$$

- ii) Input power =? $P(0)$

When $\alpha = 2.5 \text{ dB/km}$

$$\alpha = 10 \times \frac{1}{z} \log \left(\frac{P(0)}{P(z)} \right)$$

$$2.5 = 10 \times \frac{1}{z} \log \left(\frac{P(0)}{4.76 \times 10^{-9}} \right)$$

$$\log \left(\frac{P(0)}{4.76 \times 10^{-9}} \right) = \frac{2.5}{0.833} = 3$$

$$\frac{P(0)}{4.76 \times 10^{-9}} = 10^3 = 1000$$

$$P(0) = 4.76 \mu\text{W}$$

$$\text{Input power} = 4.76 \mu\text{W}$$

OPTICAL FIBER ATTENUATION MEASUREMENT

Optical Cable Attenuation Measurements

FIBER-OPTICS MONITOR



FIBRE-OPTICS MONITOR TRANSMITTER UNIT

FIBRE-OPTICS MONITOR RECEIVER UNIT

2 x 2.5mm FREE CONNECTORS

CABLE WITH 2 x 3.5mm CONNECTORS

3.5mm FREE CONNECTOR

CABLE WITH 3.5mm CONNECTOR TO CROC. CLIPS

MICROPHONE

BATTERIES FOR Tx AND Rx

INSTRUCTION MANUAL (THIS BOOK)

CARRYING CASE

Optical Cable/Fiber Continuity Testing

For continuity testing, the output power control of the transmitter and the analogue gain of the receiver should both be set to maximum, and the transmitter's rotary switch should be turned to FIXED TONE. In order to check that the units are operating correctly, line up the transmitter's emitting diodes with the receiver's detecting diode, switch on both units, and a loud tone should then be heard at the receiver. If a different tone frequency is required, this may be achieved by setting the transmitter's switch to VARIABLE TONE, and then adjusting the tone frequency control until the

OPTICAL FIBER ATTENUATION MEASUREMENT

desired frequency is obtained. The frequency of this internal generator may be monitored at the DIGITAL INPUT/ TONE MONITOR socket.

Detecting Presence of Infra-red Radiation

The Monitor receiver may be used to give an audible indication of the presence of infra-red radiation at locations such as the remote ends of optical links, cable breaks, bad joints and "lossy" optical coupling arrangements, if audio tones, such as those produced by the transmitter, are present in the signal. A short length of large core optical cable would act as a convenient probe, although the signal may be detected by simply pointing the receive diode towards the source of the radiation. D.C. (i.e. unmodulated) optical radiation may be detected by connecting a DVM (set to d.c.) to the MEAN POWER MONITOR socket. At 850nm, the reading will be approximately 50mV per μW of incident radiation, up to a maximum of 0.5V. This measurement is most suitable for conditions where ambient light is not present, for example at the end of an SMA* terminated cable which may be connected up to the receiver, thus screening off the ambient light.

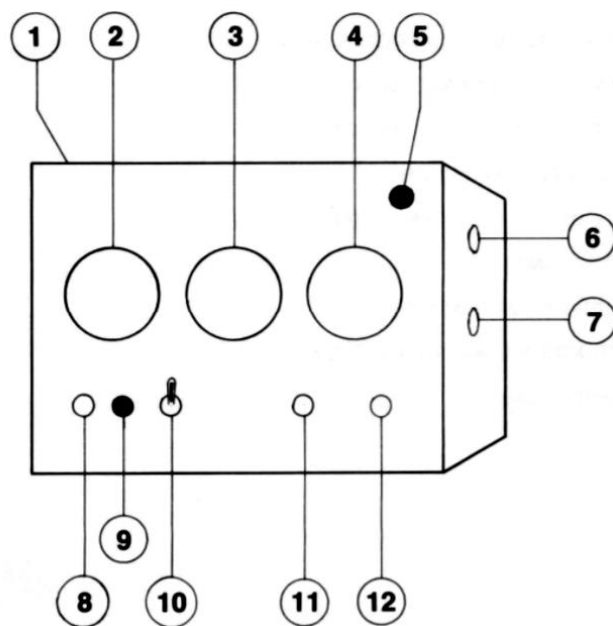

TRANSMITTER UNIT

1. Battery holder for 9V 'radio' battery.
2. Switches between analogue, digital, variable tone and fixed tone modes.
3. Controls frequency of the variable tone generator (100Hz to 5kHz).
4. Controls output intensity of high radiance infra-red I.e.d., unhoused infra-red I.e.d., and output indicator (approx. 20dB range).
5. Gives a visible indication of the output of the transmitting diodes.
6. High-radiance infra-red I.e.d. (820nm) in S.M.A.* socket.
7. Unhoused infra-red I.e.d. (880nm) window.
8. 2.5mm socket for optional external power supply of +9V to +15V d.c.
9. L.e.d. indicating adequate supply voltage.
10. ON/OFF switch for battery. Does not control optional external supply.
11. Analogue input, 20k Ω impedance, a.c. coupled, 3.5mm socket.
12. Digital input, 1.2V to 1.6V Schmitt thresholds. Also acts as output monitor for tone generator. B.N.C. socket.

OPTICAL FIBER ATTENUATION MEASUREMENT

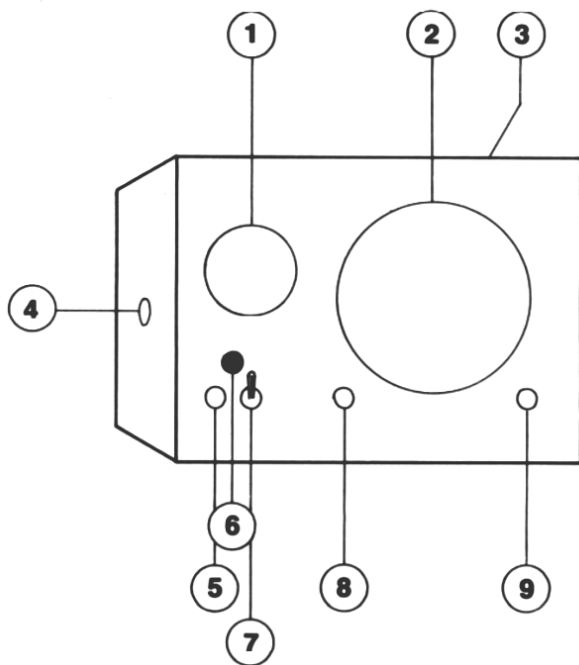

RECEIVER UNIT

1. Controls the gain of the amplifier.
2. Loudspeaker output of analogue circuit.
3. Battery holder for 9V 'radio' battery.
4. Receive diode (Si) in S.M.A.* socket.
5. 2.5mm socket for optional external power supply of +9V to +15V d.c.
6. L.e.d. indicating adequate supply voltage.
7. ON/OFF switch for battery. Does not control optional external supply.
8. Mean power monitor, 150k Ω output impedance, connected passively to receive diode (i.e. not through amplifier). 3.5mm socket.
9. Analogue output, impedance less than 1 Ω . Connection to this socket automatically disconnects the loudspeaker. 3.5mm socket.

The Fiber-Optics Monitor, in conjunction with an a.c. voltmeter, can be used to measure or monitor (over a period of time) the attenuation of an optical route, which is terminated in SMA* connectors (See Section A3 for other terminations). The various procedures are given in the following experimental steps.

Five different methods are given in following sections.

Apply carefully the steps given in each method.

(A1) Standard Measurement Method

Procedure:

1. Set the transmitter to FIXED TONE (400 Hz), and turn the analogue gain of the receiver to a minimum.
2. Connect an a.c. voltmeter which can measure a.c. values down to, or below, a tenth of a millivolt, to the ANALOGUE OUTPUT socket of the receiver. A Digital Volt Meter (DVM) with a 200mV

OPTICAL FIBER ATTENUATION MEASUREMENT

a.c. scale is ideal for this purpose. (The Mean Power Monitor socket should be left unconnected for best measurement accuracy).

3. Connect a short length (about 0.5 meter) of optical cable (of the same type as the route to be measured) between the transmitter and receiver. This reference length of cable must have flat, clean ends in order to achieve a good measurement accuracy. To ensure there is no optical overload at the receiver, reduce the transmitted output level (turn the OUTPUT POWER control anti-clockwise) until the voltmeter reading is just below 1.00V (RMS or sine—RMS--equivalent). [Refer to A4 for optical power levels which cannot be reduced to below this value]. Then take the voltmeter reading (= VREF). For optimum accuracy, it is best to take this initial reading after the units have been switched on for five minutes or more, so that equilibrium conditions are reached.

Check the electrical noise level by switching off the transmitter and noting the voltmeter reading (=VA). VA will normally be zero if the DVM specified in Step 2 is used.

4. Connect up the route to be measured between the transmitter and receiver, in place of the short length, and take the voltmeter reading (=V0).

5. The attenuation (or insertion loss) of the route is calculated using the following formula:

$$\text{attenuation} = 10 \log_{10} \frac{V_{\text{REF}}}{\sqrt{(V_0^2 - V_A^2)}} \text{ dB,}$$

$$\text{which approximates to } 10 \log_{10} \frac{V_{\text{REF}}}{V_0} \text{ dB} \quad \text{when } V_A \text{ is small compared to } V_0.$$

For measurement of a number of routes, only the final two Steps 4 and 5 need be repeated. If the output power level of the transmitter is altered, however, Step 3 must be repeated to re-set a suitable level. After measuring a number of routes, check that VREF is essentially the same as the original value. The attenuation range using the above procedure is 30dB, when a 0.1mV sensitivity voltmeter is used, and the accuracy is within ± 0.2 dB.

(A2) High Loss Method

OPTICAL FIBER ATTENUATION MEASUREMENT

In order to increase the attenuation range capability of the Monitor, Steps 4 and 5 of the procedure described in d1 are replaced by the following (which may be used to measure losses of greater than 15dB):

Procedure:

1. Connect up the route to be measured between the transmitter and receiver, in place of the short reference length.
2. Then, increase the receiver analogue gain to maximum by turning the control fully clockwise.
3. Take the voltmeter reading (= V1).
4. Measure the electrical noise by switching off the transmitter, and note the voltmeter reading (=VB).

The attenuation of the route is given by the formula:

$$\text{attenuation} = 10 \log_{10} \frac{V_{REF}}{\sqrt{(V_1^2 - V_B^2)}} + k \text{ dB} \quad \text{where the approximate value of } k = 15.$$

(k is derived from the ratio of the maximum to minimum gain of the receiver).

5. Remember to turn the receiver analogue gain back down to minimum if re-measurement of VREF is required.

The range of the instrument using this method is 45dB, while the accuracy is ± 2 dB. In order to increase the accuracy of this method, the constant k may be determined by equating the measurement results of a route with a loss between 15 and 25dB, using the Standard and High Loss Methods.

(A3) Measurement with non SMA-Terminated Cable

The attenuation of a cable route with end connectors other than SMA (US Standard)* may also be measured using the Fiber-Optics Monitor. Identical methods to those described above are used, but with short (one meter or less) interface cables connecting the Monitor to the route and reference cables.

(A4) Measurement using Mean Power Monitor Output

OPTICAL FIBER ATTENUATION MEASUREMENT

The loss of a route may also be determined by measuring the d.c. voltage at the MEAN POWER MONITOR socket of the receiver. This d.c. signal, which is proportional to the average optical input power, is present whatever the nature of modulation of the optical input, and therefore may be used with transmitters that have a constant d.c. output. This method is also most appropriate for very high optical signal levels, which may overload the analogue circuitry. (Refer to Section A1, Step 3). The measurement procedure parallels that described in Section A1, Steps 3, 4 and 5, while the reference signal level should be kept below 0.5V d.c. to avoid overload. A high input impedance meter such as a DVM must be used at the MEAN POWER MONITOR socket, since its output impedance is 150k Ω , (as opposed to less than 1 Ω for the analogue output). A 3.5mm plug may be inserted in the ANALOGUE OUTPUT socket to turn off the loudspeaker during these measurements.

(A5) Attenuation Monitoring Procedure

Due to the high stability of the Fibre-Optics Monitor units with variations in temperature and supply voltage, the equipment may be used to monitor continuously the insertion loss of an optical route. The measurement procedures are the same as those described in A1 to A4 above, with the route measurements being taken over a period of time. Changes in route attenuation may of course be calculated without recourse to the reference signal level, using the following formula:

$$\text{change in attenuation} = 10 \log_{10} \sqrt{\frac{(V_1^2 - V_N^2)}{(V_2^2 - V_N^2)}} \text{ dB,}$$

$$\text{which approximates to } 10 \log_{10} \frac{V_1}{V_2} \text{ dB} \quad \text{when } V_N \text{ is small compared to } V_1 \text{ and } V_2,$$

Here V_1 and V_2 are two separate readings with the route connected up V_N is the electrical noise level. The above formula applies to both the Standard and High Loss measurement methods.